

Washington Metropolitan Area Transit Authority  
**STATION AREA PLANNING GUIDE**

October 2017





## Acknowledgments

This guide was developed by a task force consisting of WMATA architects, engineers, planners, and consultants. The first task involved an extensive review and evaluation of the existing WMATA Standards and Criteria relevant to station site and access planning and WMATA's Joint Development Policies and Guidelines. Literature related to transit access planning and transit-oriented development was also reviewed, including a best-practice review and evaluation of existing station access planning guidelines at other transit agencies. Lessons learned from each task were used to refine WMATA's existing access guidelines for station site and access planning in coordination with "institutional knowledge" from WMATA's task force.

WMATA would like to acknowledge the contributions of the following departments to the development of this document:

Office of ADA Policy and Planning (ADAP)  
Office of Architecture (ARCH)  
Office of Bus Planning (BPLN)  
Office of General Counsel (COUN)  
Office of Joint Development and Adjacent Construction (JDAC)  
Office of Real Estate and Station Planning (LAND)  
Office of Parking (PARK)  
Office of Planning (PLAN)  
Office of Plant Maintenance (PLNT)  
Department of System Safety and Environmental Management (SAFE)



# Table of Contents

<b>Introduction</b> .....	<b>2</b>
I.1 Purpose of the Guide .....	2
I.2 Regional Background.....	2
I.3 Goals.....	5
I.4 Station Typologies.....	6
I.5 Access Hierarchy .....	6
I.6 General Design Concepts .....	11
<b>Chapter 1—Pedestrian Facilities</b> .....	<b>14</b>
1.1 Principles.....	14
1.2 Practices .....	14
1.3 Standards.....	17
<b>Chapter 2—Bicycle Facilities</b> .....	<b>24</b>
2.1 Principles.....	24
2.2 Practices .....	25
2.3 Standards.....	26
<b>Chapter 3—Bus and Regional Rail Facilities</b> .....	<b>30</b>
3.1 Principles.....	30
3.2 Practices .....	31
3.3 Standards.....	34
3.4 LRT/BRT Principles.....	37
3.5 LRT/BRT Practices.....	37

<b>Chapter 4—Shuttle Facilities . . . . .</b>	<b>48</b>	<b>Chapter 9—Maintenance Considerations . . . . .</b>	<b>100</b>
4.1 Principles.....	49	9.1 Principles.....	100
4.2 Practices.....	49	9.2 Practices.....	101
4.3 Standards.....	49	9.3 Standards.....	101
<b>Chapter 5—Vehicular Drop-Off/Pick-Up Facilities, Car Share, and Ride Hailing . . . . .</b>	<b>52</b>	<b>Chapter 10—Interim Facilities . . . . .</b>	<b>104</b>
5.1 Principles.....	53	10.1 Principles.....	104
5.2 Practices.....	53	10.2 Practices.....	105
5.3 Standards.....	55	10.3 Standards.....	105
<b>Chapter 6—Vehicular Parking and Circulation . . . . .</b>	<b>62</b>	<b>Appendices . . . . .</b>	<b>108</b>
6.1 Principles.....	62	A.1 Regulations and Controls .....	108
6.2 Practices.....	63		
6.3 Standards.....	67		
<b>Chapter 7—Joint Development . . . . .</b>	<b>72</b>		
7.1 Principles.....	73		
7.2 Practices.....	74		
7.3 Standards.....	85		
<b>Chapter 8—Wayfinding and Landscape Design . . . . .</b>	<b>88</b>		
8.1 Principles.....	88		
8.2 Practices.....	89		
8.3 Standards.....	96		





# Introduction

## I.1 Purpose of the Guide

The purpose of the Station Area Planning Guide is to provide clear, concise design guidance for station site and access planning at Metrorail stations so that transit customer and employee safety and security are prioritized, access to the station is optimized for all modes of arrival, and high-quality transit-oriented communities are created. It is intended for use by the Washington Metropolitan Area Transit Authority (WMATA, or Metro), local jurisdictional planners, related government agencies, and WMATA's real estate partners with interests in planning transit facilities or in proposing development at Metrorail stations.

Metro welcomes creative approaches in meeting the competing needs of each access mode in the context of each transit station's unique setting and characteristics, and Metro acknowledges these approaches will evolve over time. However, all design solutions must take into account Metro's transit access requirements and criteria for effective transit operations. This guide is a living document that will evolve, and WMATA will update and refine it as the need arises.

## I.2 Regional Background

In June 2013, the WMATA Board of Directors adopted *Momentum*, a strategic plan meant to guide Metro's direction for the next ten years.

The *Momentum* strategic plan calls for:

- Building and maintaining a premier safety culture and system.
- Meeting or exceeding expectations by consistently delivering quality service.
- Improving regional mobility and connecting communities.
- Ensuring financial stability and investing in our people and assets.

Steady growth in the region has generated increased transit ridership, but has also led to more vehicle traffic at station areas. As a result, different modes of access often come into conflict in station areas. As such, WMATA and local jurisdictional planners need to assess whether existing conditions for pedestrian access, bus operations, and vehicular traffic are adequate to meet current capacity needs and future demand. Planning for first and last mile solutions such as bike share, transportation network companies, micro-transit, shuttles, and ridesharing in station design and access capacity are an increasingly important element in high quality neighborhoods and enhancing placemaking in surrounding neighborhoods.

Goals that reflect this vision will “yield a more prosperous, accessible, livable, and sustainable metropolitan Washington” (Metropolitan Washington Council of Governments, Region Forward Vision, <https://www.mwcog.org/community/planning-areas/regional-planning/region-forward/goals/>).

Improving access to and from Metrorail stations is critical for meeting ridership goals and serving customer needs.

Potential customers will not use Metrorail if station access is difficult due to:

- Pedestrian paths that are indirect and fragmented.
- High traffic volumes and traffic conflicts in and around the station.
- Connecting bus service that is slow, infrequent, and/or unreliable.

- Pick-up/drop-off spaces are inconvenient or limited, and/or access is not provided for shuttle buses.
- Short-term and long-term parking areas being full or unavailable.
- Access routes that are not perceived as safe and or convenient.
- Bicycle parking that is perceived to be either unavailable, inconvenient, and/or not secure.

Potential riders may also be lost if their door-to-door journeys, that includes Metro is more expensive, time-consuming, unreliable, or frustrating than alternative means of travel, such as driving.

Ultimately, the goal of improving station access is to better serve existing customers while still attracting additional customers by:

- Enhancing the pedestrian experience with a safer and more attractive walking environment.
- Maintaining a good level of service for transit access to the site for buses and connecting rail.
- Accommodating future access needs and new modes of arrival.
- Making transit use more convenient, efficient, and attractive.



**Figure I.1**—Metrorail riders reach the station through many modes of arrival.

### **I.3 Goals**

This guide seeks to inform how transit station areas can meet or exceed expectations by consistently delivering quality service and improve regional mobility and connect communities.

Specifically, the goals for this guide are to:

#### **I.3.1 Prioritize Safety**

This document guides the planning and design of station sites and access to prioritize the safety of employees, riders, and neighboring communities.

#### **I.3.2 Focus on Customer Service**

Efficient rider access and transfers will improve customer experiences. Additionally, thoughtful site planning and transit-oriented development can encourage economic development and social and economic vibrancy in the service area.

#### **I.3.3 Invest in Place Making**

Metrorail and Metrobus sites are central to placemaking in neighborhoods throughout the Washington, DC region. Attractive and well-designed transit sites can improve the quality of life of users and residents in surrounding areas by encouraging use of transit, bicycling, and walking. Efficient and integrated transit facilities can enrich civic pride, encourage diverse use of desirable public open spaces, and support economic growth. This document guides integration of Metro operations to enhance service areas and encourage multiple uses and benefits for riders and neighboring communities.

#### **I.3.4 Integrate Sustainability**

Sustainability priorities support placemaking and responsible development that benefits surrounding ecosystems. Attractive and inviting spaces can also be ecologically productive landscapes. Prioritizing sustainability also supports a sense of well-being, safety, and financial responsibility through the thoughtful use of materials and technology in the design of places. Examples include high-efficiency smart lighting systems that improve lighting coverage and consume less energy, facilities that manage stormwater through ecological systems, and facilities that require less maintenance.

#### **I.3.5 Encourage Transit-Oriented Development**

Transit-oriented development can contribute to the financial sustainability of Metro and help to deliver Metrorail and Metrobus service quality and operations. Transit-oriented development can lower per capita automobile ridership and its resulting carbon footprint, while simultaneously facilitating economic growth and creating placemaking opportunities that enhance social activity in areas served by Metro transit. Additionally, transit-oriented development has the capacity to improve WMATA's bottom line by increasing ridership without increasing congestion.

## I.4 Station Typologies

The Metrorail system is a regional system, with several types of stations having different characteristics. A station's type may change over time due to local or regional growth, or due to changes in the transportation system. Typical station types include:

- **Core Stations:** These are stations located in high-density employment areas and mixed-use destinations. These stations are accessible primarily by walking, bicycling, and bus.
- **Mid-Line Stations:** Mid-line stations are typically located in areas with low to medium density, and are usually accessed by Park & Ride, Kiss & Ride, bus, bicycling, and walking modes. Mid-line rail stations operate differently from one another, with varied access to multi-modal transport options, including commuter rail, commuter bus, streetcar, and intercity rail. In some cases, mid-line rail stations are the terminus of a large number of bus routes.
- **Terminus Stations:** Terminus stations are located at the ends of Metrorail lines. Typically, terminus stations are accessed through Park & Ride, bus, and Kiss & Ride more than by pedestrians and cyclists. However, comprehensive regional planning that improves pedestrian and bicycle access to stations could increase the walking and bicycle modes. Terminus stations typically serve a wide geographical area that extends beyond the greater Washington, DC area, creating a high demand for the Park & Ride mode.

## I.5 Access Hierarchy

The WMATA Board of Directors established an access hierarchy to guide station site planning and design. This access hierarchy informs the location of various circulation routes and transfer facilities based on prioritized convenience and each access mode. The hierarchy applies to station site planning for new Metrorail stations, existing stations where transit facilities are modified to accommodate joint development, or other station site improvements on WMATA property.

No matter which mode of access is used, Metro facilities should be designed to meet the needs of passengers of all ages with mobility and sensory disabilities. Accessible design also benefits other passengers besides those with disabilities, such as parents with young children in strollers or passengers traveling with luggage, and should optimize safety and ease of access for all pedestrians. The access hierarchy is described as follows:

### I.5.1 Pedestrians

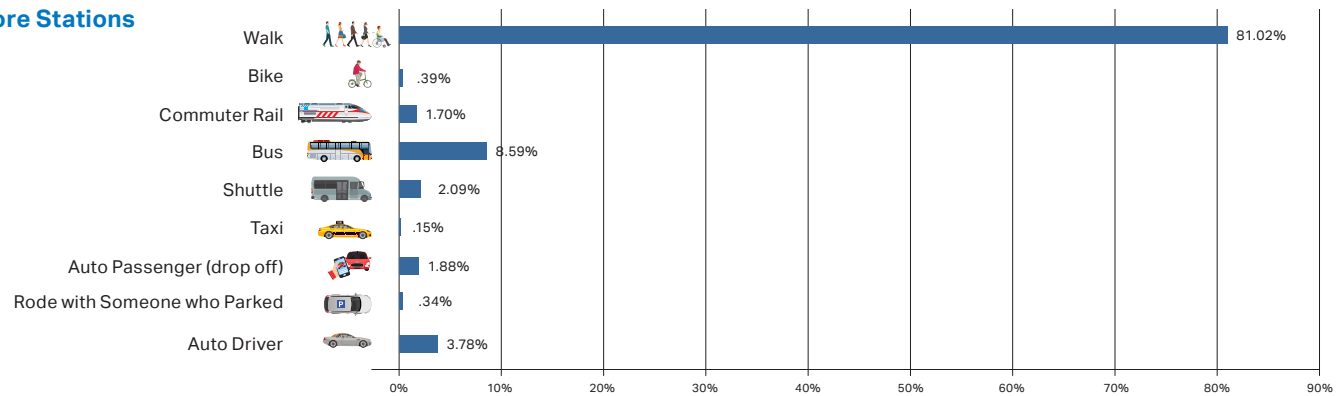
At some point during their trip, all Metro customers are pedestrians within the station area, and as such, pedestrian circulation is given the highest priority. As part of resolution 2011-10, The WMATA Board of Directors further endorsed the priority for safe, convenient, and intuitive pedestrian access, acknowledging that clear, continuous, and integrated pedestrian paths to the station will encourage more customers to walk. WMATA will work with all jurisdictions to design and connect pedestrian access between station facilities and adjoining properties or rights-of-way.

### Average Metrorail Access Mode Share (by Station Type)

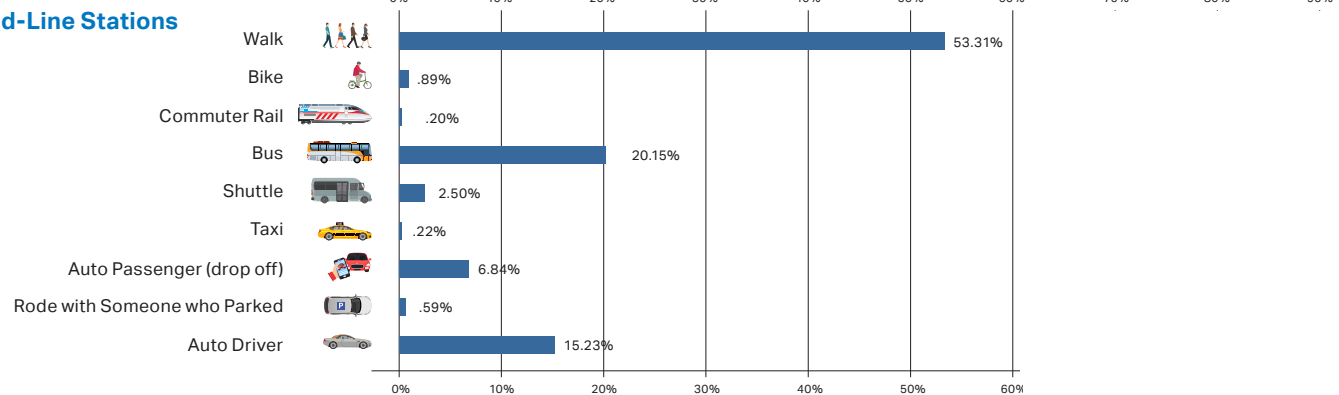
These graphs show the average access mode share per station typology. Metro ridership survey data shows that for each station type, the average access mode share percentages vary widely. For instance, the average share of riders accessing Core Stations by bus is roughly 8.6% compared to 22% for Terminus Stations. The greatest differences are seen between the walking and drive shares at Core and Terminus stations.

Source: 2012 Metrorail Passenger Survey

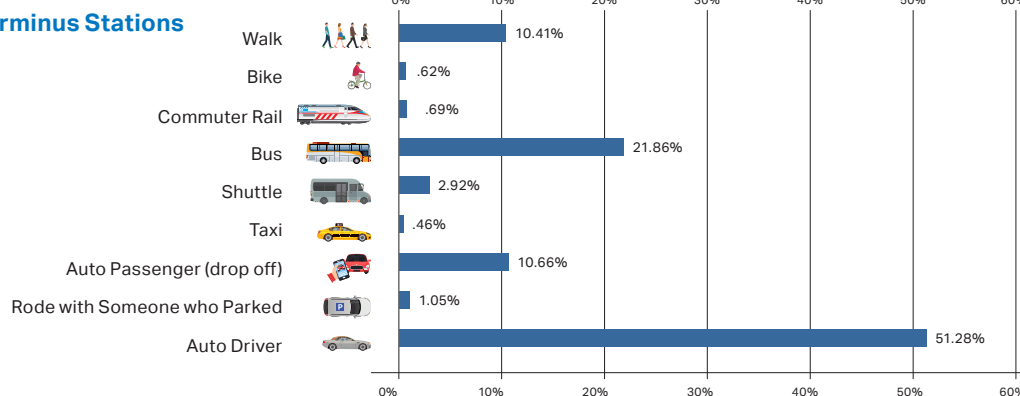
#### Core Stations



#### Mid-Line Stations



#### Terminus Stations

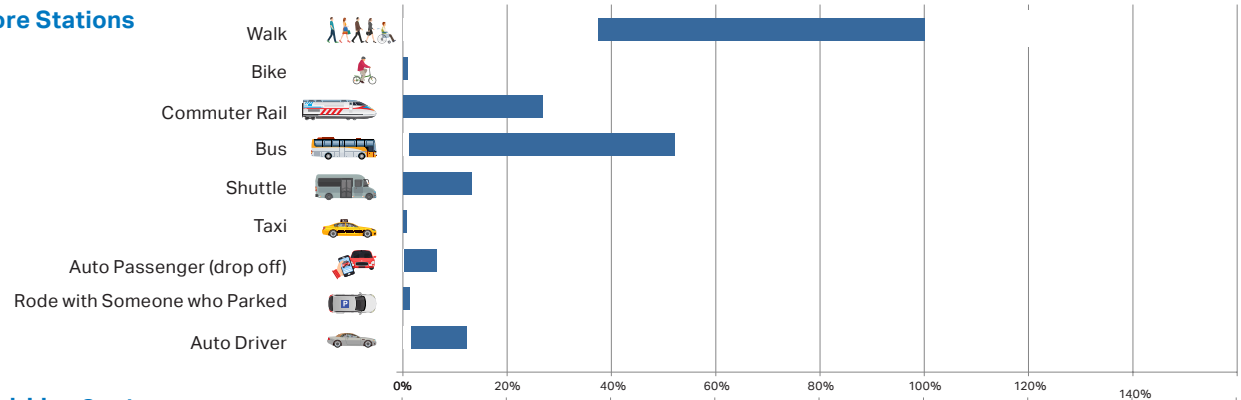


### Range of Metrorail Access Mode Shares (by Station Type)

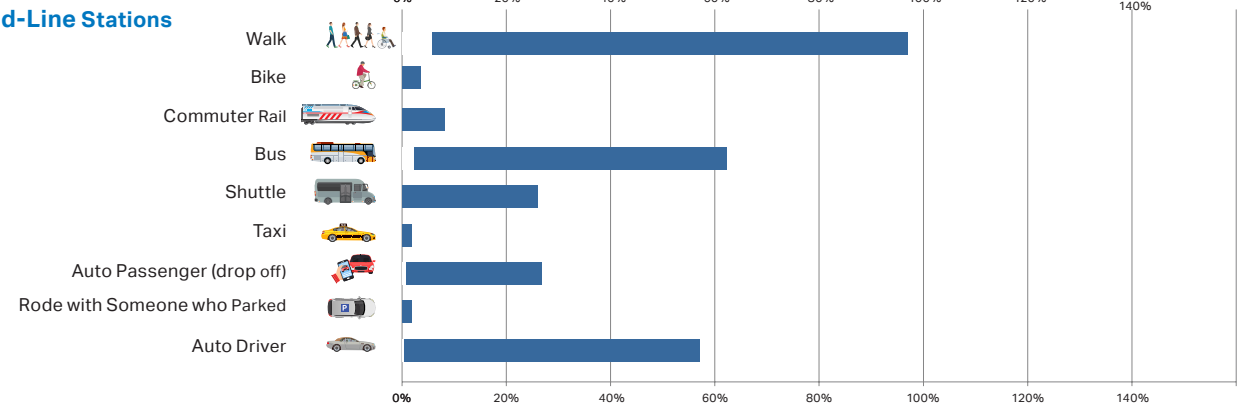
The average mode share does not tell the whole story. Metro ridership survey data shows that within each station type, the range of each access mode shares differs dramatically. The range of each mode of access is shown in the graphs to the right. For instance, the percentage of people accessing Core stations by walking ranges from about 40-100%. This demonstrates the need for context sensitive solutions that take into account the specific demands and characteristics of each station.

Source: 2012 Metrorail Passenger Survey

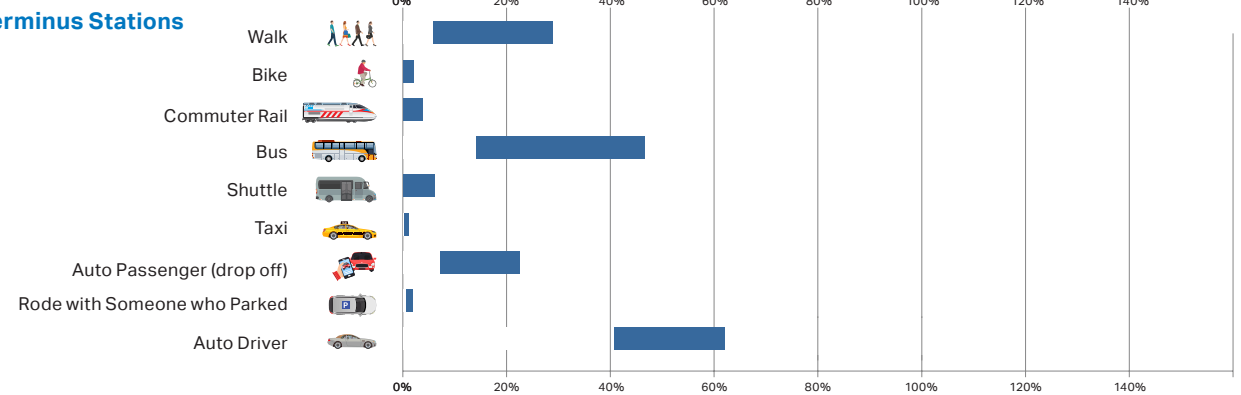
#### Core Stations



#### Mid-Line Stations



#### Terminus Stations



### **I.5.2 Bicycles**

Board resolution 2011-10 endorses improved bicycle access and amenities at Metrorail stations. In addition, the WMATA Board of Directors has set a target for bicycle mode access to reach 2.1% by 2020, and 3.5% by 2030 (from the 2007 baseline of 0.7%). Bicycles provide critical last-mile connectivity with surrounding neighborhoods and the Capital Bikeshare system provides a new way of extending the reach and flexibility of public transportation. To help achieve these goals, bicycle parking and bike share amenities are given priority placement near Metro entrances, and bicycle routes will be increasingly better defined and amenitized. While bicycles in the station area have right-of-way over buses and automobiles, they do not have right-of-way over pedestrians. Convenient bicycle access to the station should be provided without encouraging conflicts with bus loop circulation.

### **I.5.3 Transit**

Since Metrobus and connecting rail generate a higher share of concentrated pedestrian activity on station sites, transit facilities should be given priority locations near the station entrance over all other vehicular modes of access.

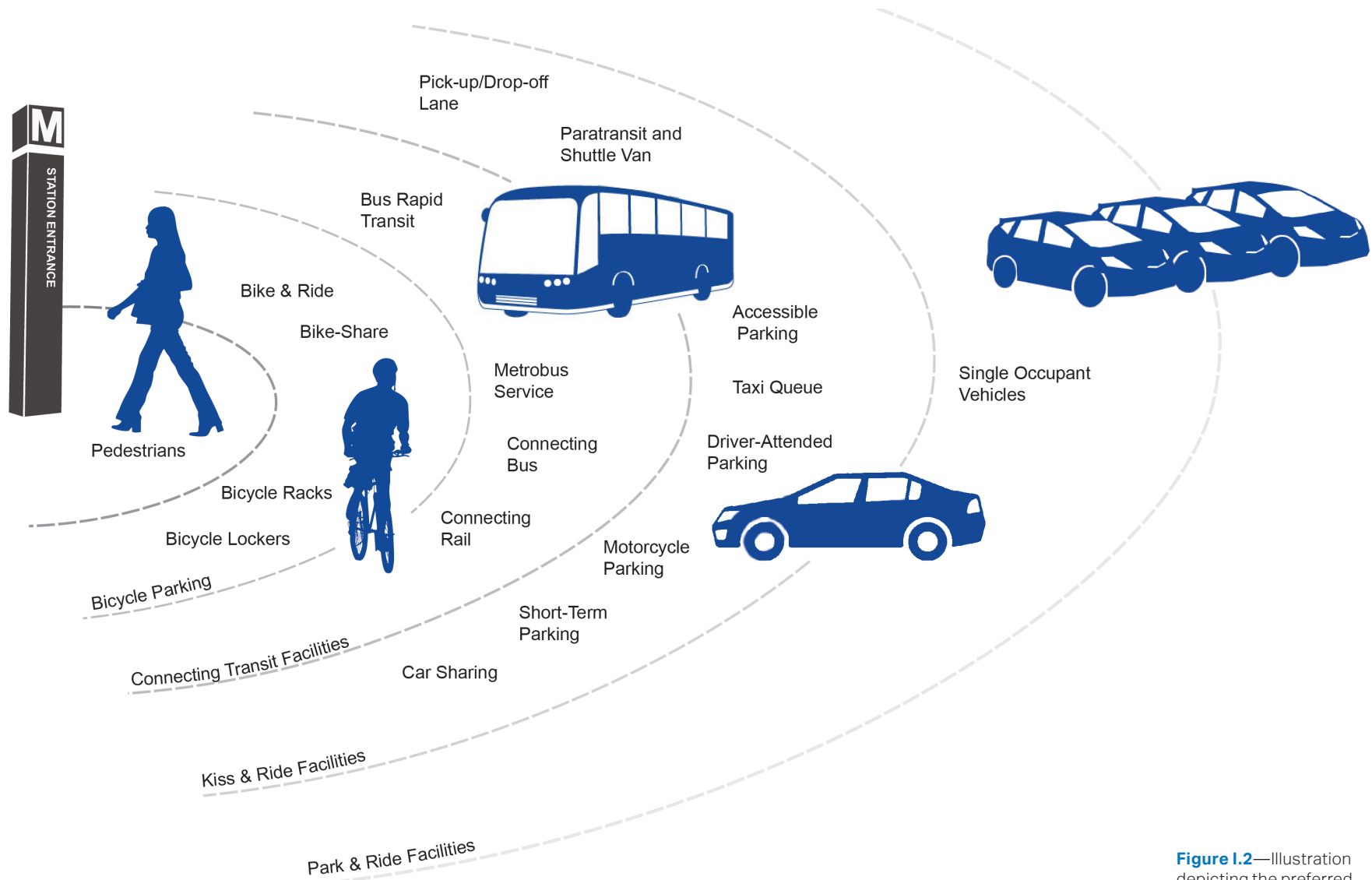
### **I.5.4 Kiss & Ride**

Kiss & Ride facilities are the pick-up and drop-off location for private vehicles, taxis, ride hailing services, shuttle vans, car sharing services, and some short-term parking. These facilities require strong connectivity to a station entrance for optimum function. They facilitate pick-up

and drop-off for numerous vehicle types throughout the day, and especially at peak transfer periods. For these reasons, they are afforded a higher access priority than Park & Ride facilities. National trends show an increased use of car-sharing and ride-sharing services and programs that are offered on-demand, at a higher frequency, and/or at a higher capacity. Demands on Kiss & Ride is expanding as a result.

### **I.5.5 Park & Ride**

Park & Ride facilities are generally used as all-day commuter parking. Park & Ride is considered an important transit mode of access to/from Metrorail and the regional transportation system, and should be accommodated where appropriate. Available parking at stations can divert drivers from the region's roadways to transit alternatives, and provide an opportunity for customers to use the Metro system who may not be able to use other modes to access stations. However, Park & Ride has a low share of transit riders per vehicle, and can detract from other, more efficient modes of access. In terms of energy-efficiency, cost of providing access infrastructure, orientation toward commute-only (rather than all-purpose) riders, and overall sustainability, Park & Ride is the least desirable mode of access. Nonetheless, it is critical for supporting ridership at many suburban stations. As transportation technologies and land use patterns change, WMATA may reevaluate the need for Park & Ride facilities at particular sites.



**Figure I.2**—Illustration depicting the preferred multi-modal access hierarchy.

### I.6 General Design Concepts

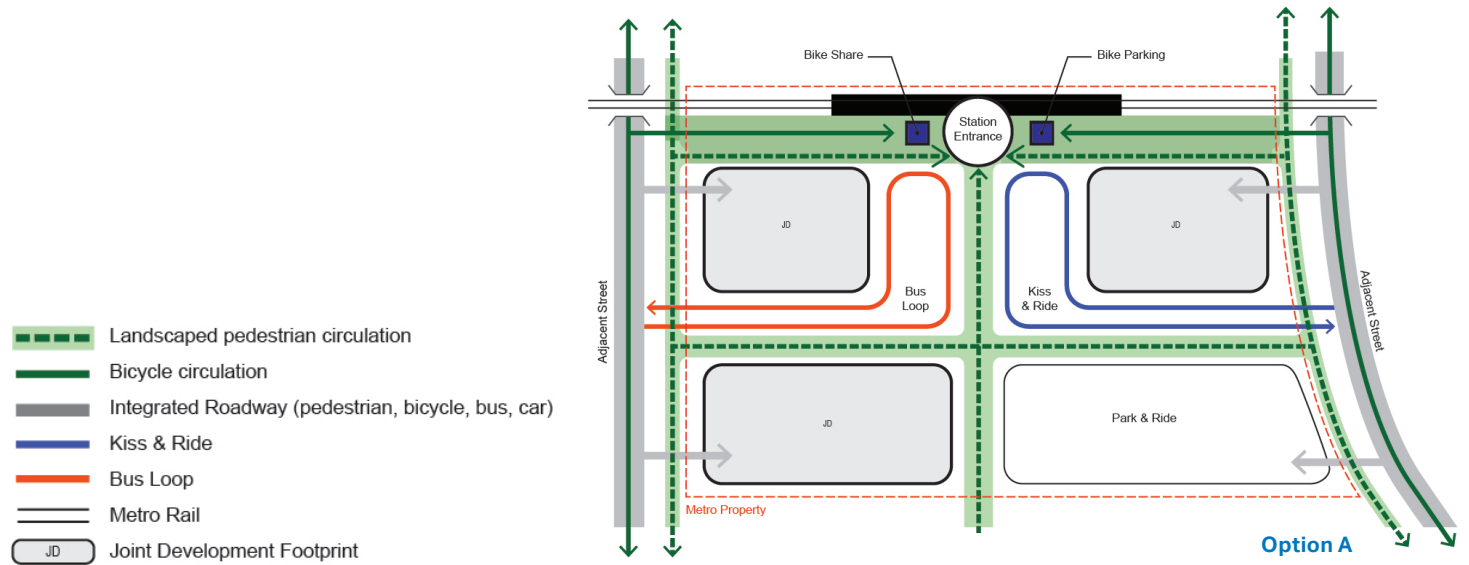
This planning document focuses on station facilities located on WMATA-owned property. To ensure that access to stations and functionality of local transportation systems are maintained, master plans for any new station, any transit-oriented development on WMATA property, or any improvements to existing station facilities, should be closely coordinated with relevant jurisdictional and state authorities. All transit facilities, pedestrian waiting areas, and accessible paths should meet the requirements of the Americans with Disabilities Act (ADA) Standards for Transportation Facilities.

The station site plan should respect existing topographic conditions, including existing natural vegetation, with the goal of minimizing grading and destruction of

natural conditions. Station areas should be designed to enhance the communities in which they are located.

The physical layout of the site should also be consistent with the access hierarchy discussed earlier. However, there can be numerous ways to achieve this goal. There is no one prototype that works for all situations. Each station site plan should address a site's specific conditions, access mode split, and unique transit oriented development (TOD) goals.

Three sample alternative site plans are shown below to illustrate different ways of organizing circulation, transit operations, and joint development. The alternatives differ in the level of separation and/or integration of site



**Figure I.3**—Illustrations depicting options for organizing circulation, transit operations, and joint development.

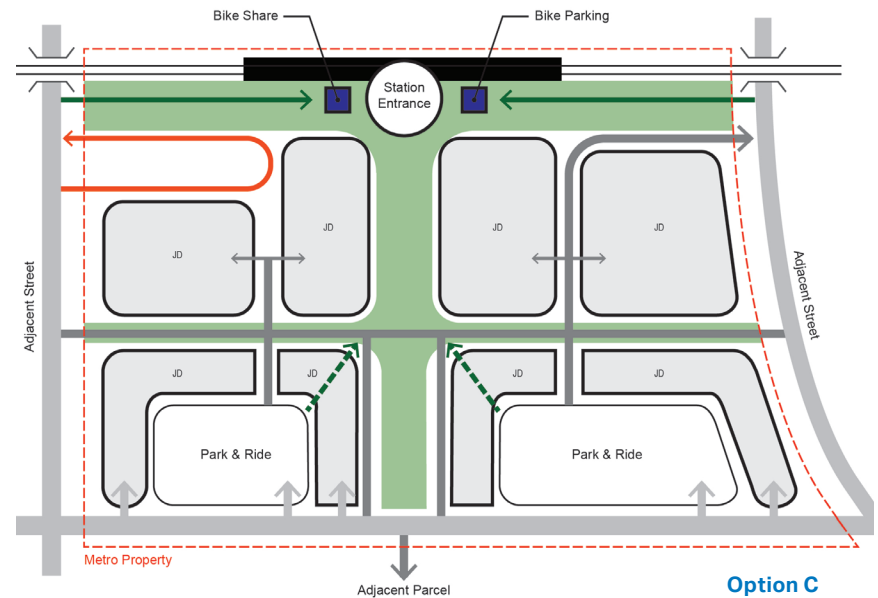
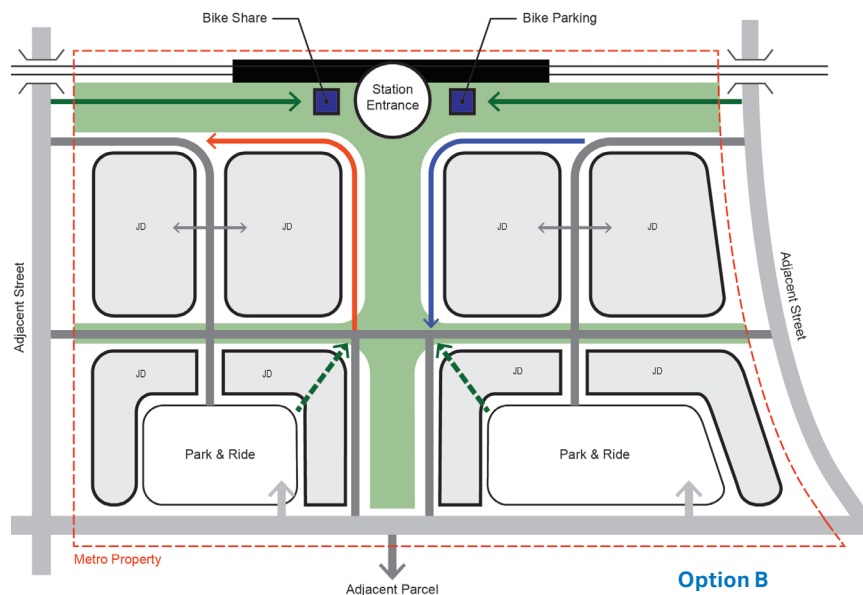
circulation, and the relationship between private development and transit facilities.

Option A shows the greatest level of access mode separation and includes distinct parcels for joint development. Pedestrian routes are the central organizing feature of the site, and the Kiss & Ride and bus facilities have their own distinct, uninterrupted loops. This option prioritizes auto and bus access which may be applicable at terminal stations.

Option B illustrates a higher level of integrated circulation. An internal street grid has been established

that conveys mixed traffic. Joint development is organized around a central open space, flanked by dedicated curbside areas for buses and Kiss & Ride activities. Park & Ride may be facilitated through parking lots or garages. This option balances the different access mode types.

Option C also illustrates a higher level of integrated circulation by means of an internal street grid. Joint development is organized around a central open space, and Park & Ride functions may be facilitated through parking lots or garages. In this case, there is a dedicated bus loop and no dedicated space for Kiss & Ride functions. This option responds to high bus traffic and low driver access mode shares.







# Chapter 1—Pedestrian Facilities

Good pedestrian access to station entrances is essential in station site and access planning because all transit customers eventually become pedestrians while transferring between modes. The following guidelines are provided for improving pedestrian access at Metrorail stations.

## 1.1 Principles

Pedestrian facilities should be designed to achieve the following:

- Create a comfortable, welcoming, and appealing experience for customers of all ages to help maintain and increase ridership.
- Provide safe pedestrian access to and through the station area to protect the health and welfare of Metro customers.
- Provide intuitive and convenient pedestrian access to station entrances.
- Minimize conflicts with other transportation modes and limit congestion.
- Create an accessible, barrier-free pedestrian network for all users consistent with ADA Standards for Transportation Facilities, and ADA Standards for Accessible Design.

## 1.2 Practices

The practices below should be followed to achieve the above principles:

### 1.2.1 Pedestrian Network

- Pedestrian paths should avoid crossing vehicular access roads and bus lanes, but not at the expense of providing direct, intuitive routes. In accordance with the access hierarchy, pedestrian routes should not be less direct than private vehicle routes. If a pedestrian crossing is unavoidable, a clearly marked crosswalk should be provided, and should be signalized if WMATA determines that the volume of pedestrians crossing warrants traffic controls.

- Rather than planning separate pathways where some are ADA accessible and others inaccessible, all pathways should be accessible for all users.
- Pedestrian paths should be located in highly visible, well-lit areas to enhance the safety of transit customers.
- Accessible routes should connect all transit facilities and public spaces. Street furniture, lighting fixtures, signposts, newspaper stands, trash receptacles, and other elements, including hand rails along the edge of the pathway, must be located outside of the accessible route. Avoid locating grates along accessible routes, which may cause problems for people with visual impairments using canes or those using mobility aids.
- When unavoidable, landscape buffers and physical barriers, such as fencing, should be considered with the purpose of guiding pedestrians toward crosswalks in a visually pleasing and ecologically sensitive manner.
- Avoid designing pathways with severe changes in elevation, which create especially difficult conditions for persons with disabilities. Curbs, steps, and stairways create obstacles for persons in wheelchairs, as well as people with strollers or wheeled luggage.
- Curb ramps must be provided to allow access for wheeled devices from areas raised and/or separated by curbs.
- Ramps should be located along the logical direction of pedestrian travel. Curb ramps should align with crosswalks to help direct customers with impaired

vision or who are blind. Ramps must have detectable warnings when provided at vehicular crosswalks. Crosswalks without ramps must also have detectable warnings.

- Where possible, pedestrian circulation through parking areas should be consolidated into convenient pathways.

### 1.2.2 Walkway Surfaces, Stairs, and Egress

- The surface of a walkway should be firm and stable enough to support the higher point loads of wheelchair wheels, crutch tips, and other mobility aids. Monolithic paved surfaces, such as asphalt or concrete, are preferred in areas of high volume traffic. Unit pavers may be used if they can provide a stable and level surface that meets the ADA Standards for Accessible Design. Beveled pavers should not be used. Architectural style and appearance should always be balanced with accessibility and the need for stable, firm, and slip-resistant surfaces.
- If stairways are provided, make sure that they are wide enough to allow faster pedestrians enough room to pass. Provide a bike channel, running at the same angle as the steps, for customers to walk a bike along the stairway where appropriate. This bike channel must not preclude stairway compliance with the ADA Standards for Accessible Design.
- If a stairway is located along the path of egress from a station entrance, it should meet emergency station egress requirements.

### 1.2.3 Pedestrian Crossings

Pedestrian crossings should be designed to be easily identified by pedestrians and transit operators and private vehicles. Pedestrian crossings channel pedestrian movements to specific locations where the pedestrian can be warned of approaching transit vehicles. They also create specific locations where the transit operators can anticipate that pedestrians will cross their path of travel. The following are criteria for the design and location of pedestrian crossings:

- Pedestrians should have the right-of-way over all motorized and non-motorized vehicles in station areas.
- Crosswalks should be located at all vehicular crossings and accentuated with textured pavement, color, and/or striped markings.
- All crosswalks should be well-lit (refer to Chapter 8).
- In accordance with jurisdictional requirements, pedestrian-activated crosswalk lighting, with countdown displays, should be provided for high-traffic areas like signalized intersections immediately adjacent to the station.
- Medians should be considered in any streets wider than four lanes to provide a refuge island for pedestrians. Consider angled crosswalks within the median to provide more space for bicyclists and to direct pedestrians to look at oncoming traffic within tolerances outlined by the ADA Standards for Accessible Design.

- Mid-block crossings may be used when there is clear pedestrian demand for a particular route.

### 1.2.4 Grade-Separated Crossings and Pedestrian Tunnels

- Ground-level pedestrian paths are preferred to encourage safe streets, reduce infrastructure costs, and support street retail, if any, in station areas.
- Bridges and tunnels may be used to avoid conflicts with other modes, or to take advantage of changes in topography in a way that would reduce the need for stairs, and enhance access for persons with limited mobility. Bridges and tunnels may be most beneficial in areas where there is high pedestrian demand to cross freeways or expressways, or in places where young children must regularly cross high-speed or high-volume roadways.

### 1.2.5 Entrance Plaza

- Entrance plazas at metro stations can be very congested and should be designed to first address transit customer access to and from the station.
- The plaza in front of the station entrance should also be designed to create a sense of place and serve as a focal point of the station area.
- The plaza should be designed to enhance the station environment and pedestrian experience by including space for bike racks, bike lockers, a bike share station, landscaping, shade trees, lighting, wayfinding, and pedestrian amenities.

- The plaza should feature clear transit information for buses and other transit services in the area.
- The plaza should be designed to provide a comfortable environment for transit customers to sit and wait for connecting transit services (e.g., transferring to bus or Kiss & Ride).
- The plaza at the station entrance should be connected with the pedestrian network that connects transit facilities and the local infrastructure.

### 1.3 Standards

The following standards apply when implementing the previous practices.

#### 1.3.1 Pedestrian Network

- Unless the pathway is weather-protected, the maximum walking distance from Metro facilities to the station entrance is 1,500'-0", measured along the actual pedestrian travel route.
- Where stairs are required, they should be located outside of the accessible route. Stairs must be the same width as the required walkway width, with 12-inch maximum treads, 6-inch maximum closed risers, rounded and slip-resistant tread nosing, and continuous handrails on both sides.
- Vertical clearance of at least 8'-0" should be provided along all accessible routes. Vertical clearance is necessary to accommodate taller persons and cyclists, and to allow for an area free of obstructions that could be hazardous to people with visual impairments.

- Provide resting areas for people with lower stamina or health impairments every 300'-0" along longer distance paths. Resting areas may include benches, seating walls, and railings.
- Refer to ADA Standards for Transportation Facilities (USDOT 2006) for specific guidance for planning and detailing pedestrian networks.
- The intersections of pedestrian pathways should be curved for ease of circulation and to reduce maintenance. Radii of these curves should be 4'-0" minimum for 90 degree angles, 10'-0" minimum for obtuse angles, and 3'-0" minimum for acute angles.

#### 1.3.2 Intersections, Crosswalks, and Medians

- Two curb ramps per corner should be provided at intersections, one in the direction of each crosswalk. Providing only one curb ramp at the apex may unintentionally direct pedestrians with visual impairment or persons using wheelchairs into the center of the intersection, rather than toward the crosswalk. Appropriate tactile paving surfaces and audible signals should be installed at all controlled and uncontrolled roadway crossings along accessible routes.

#### 1.3.3 Grade-Separated Crossings and Pedestrian Tunnels

- If tunnels are necessary, they should be well-lit, with a minimum 18-foot-wide cross-section for visibility and user comfort (refer to Chapter 8).



### Consider this...



Consider integrating transit and bicycle circulation in the heart of public spaces to improve activation and public safety.

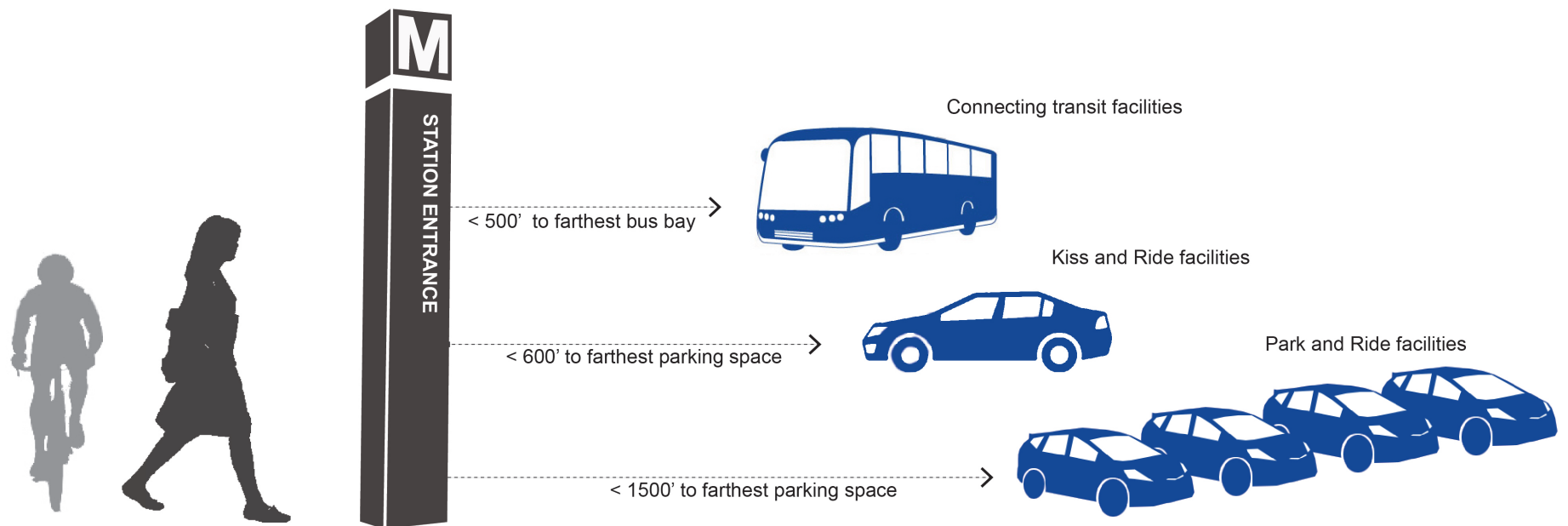
*Example: Cleveland Public Square, Cleveland, OH*

**Figure 1.1**—Photograph depicting intuitive pedestrian routes to station entrance.

### 1.3.4 Pedestrian Facilities Site Design Standards

Recommended maximum walking distances of station facilities from station entrances are depicted in Table 1.1.

NOTE: Distances shown reflect the maximum horizontal distance allowed as measured along the actual pedestrian path. Shorter walking distances are preferred.



**Figure 1.2**—Illustration depicting recommended maximum horizontal walking distance guidance from station entrance to each mode of transportation.

**Table 1.1**—Pedestrian facility dimensions

Facility	Standard
Pedestrian Walkways	<ul style="list-style-type: none"> <li>8'-0" minimum clear width in locations where pedestrian desire lines in the peak hour flow in predominantly one direction. Cumulative 12'-0" minimum clear width at point obstruction* locations</li> <li>12'-0" minimum clear width in locations where pedestrian desire lines in the peak hour flow predominantly in two opposing directions</li> <li>16'-0" minimum clear width in locations where pedestrian desire lines flow in multiple opposing and or intersecting directions</li> <li>6'-0" minimum clear width on each side of any point obstruction*</li> <li>The minimum clear walkway width along bus platforms should be based on the number of bus bays in the array. Refer table 1.2</li> </ul>
Crosswalks and Curb Cuts	<ul style="list-style-type: none"> <li>Minimum width same as walkways required at all walkway/road intersections</li> <li>Any variation from pedestrian width requirements will require WMATA approval</li> <li>Crosswalks must be the high-visibility (zebra stripe) style</li> </ul>

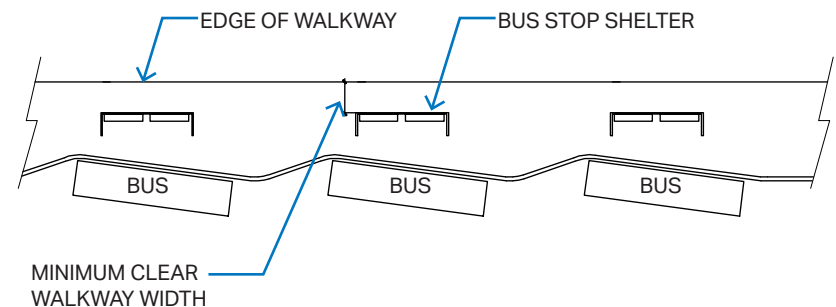
\*Point obstructions are defined as any vertical element measuring less than 24" x 24" in horizontal dimensions

**Table 1.2**—The minimum clear walkway width along bus platforms

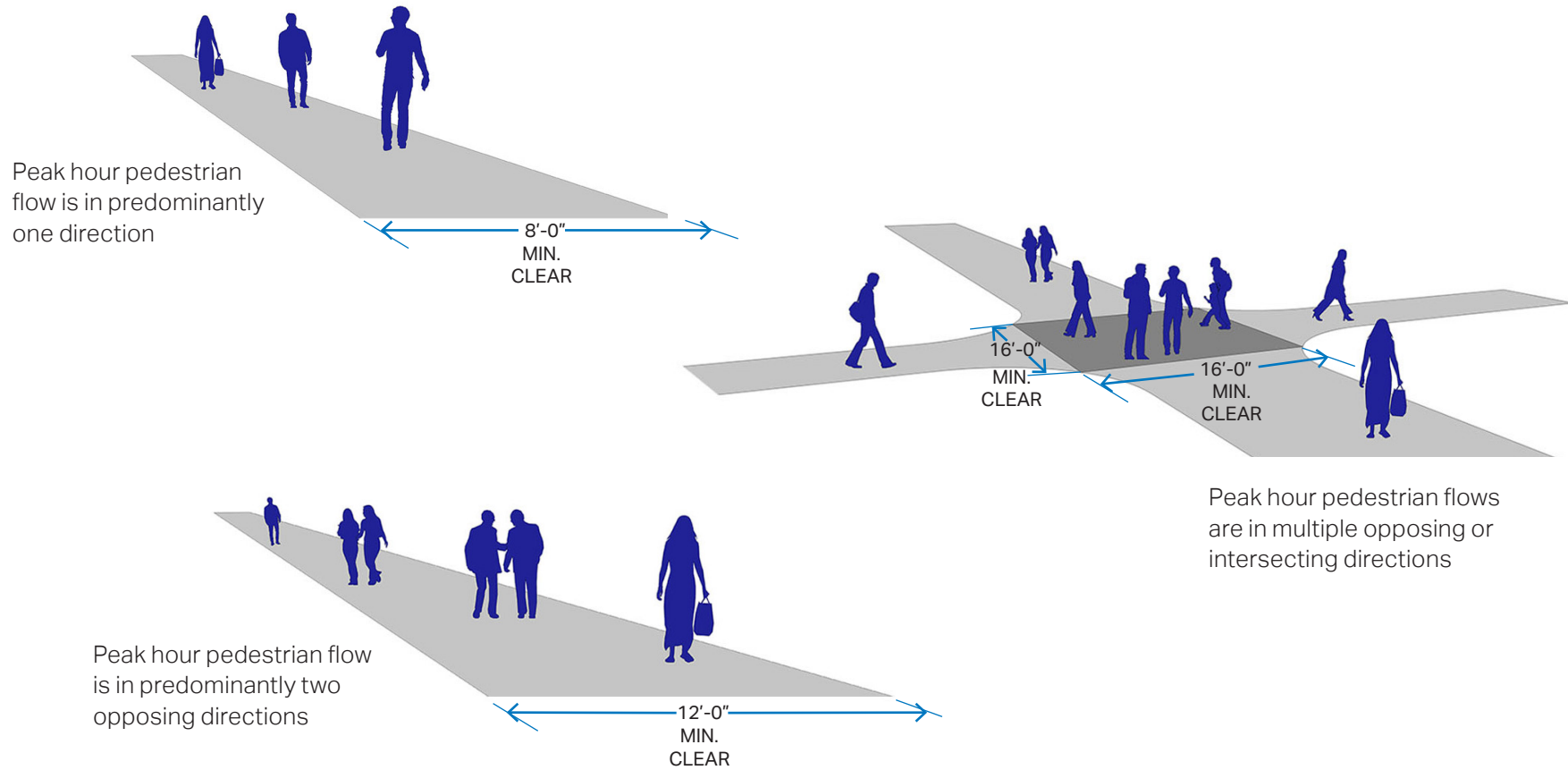
Number of Bays in the Array	Minimum clear walkway width*
4 or less	8'-0"***
5	10'-0"***
6 or more	12'-0"***

\*Regardless of the number of bus bays, in cases where bus platform pedestrian traffic is combined with other pedestrian traffic, the minimum clear walkway width should be 12'-0".

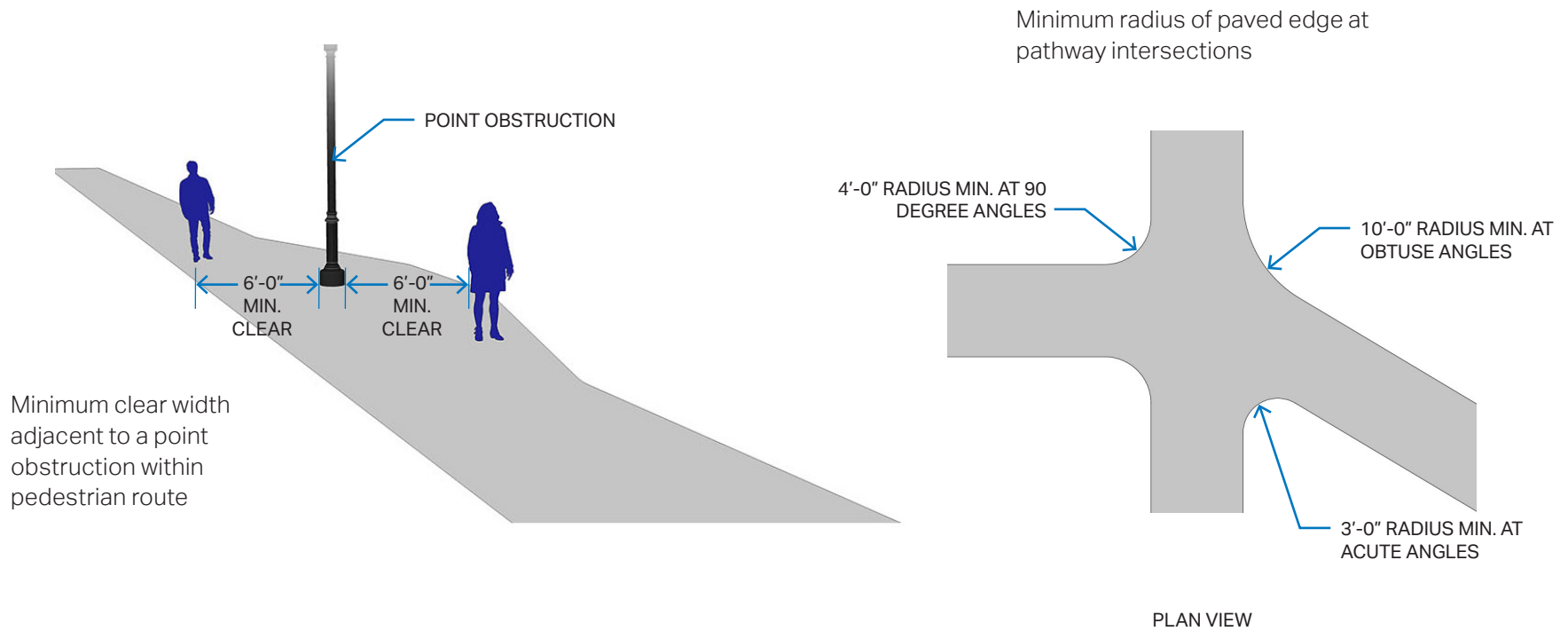
\*\* WMATA staff can revise the minimum clearance at specific locations on a case-by-case basis



**Figure 1.3**—Illustration depicting recommended minimum clear walkway widths along bus bays.

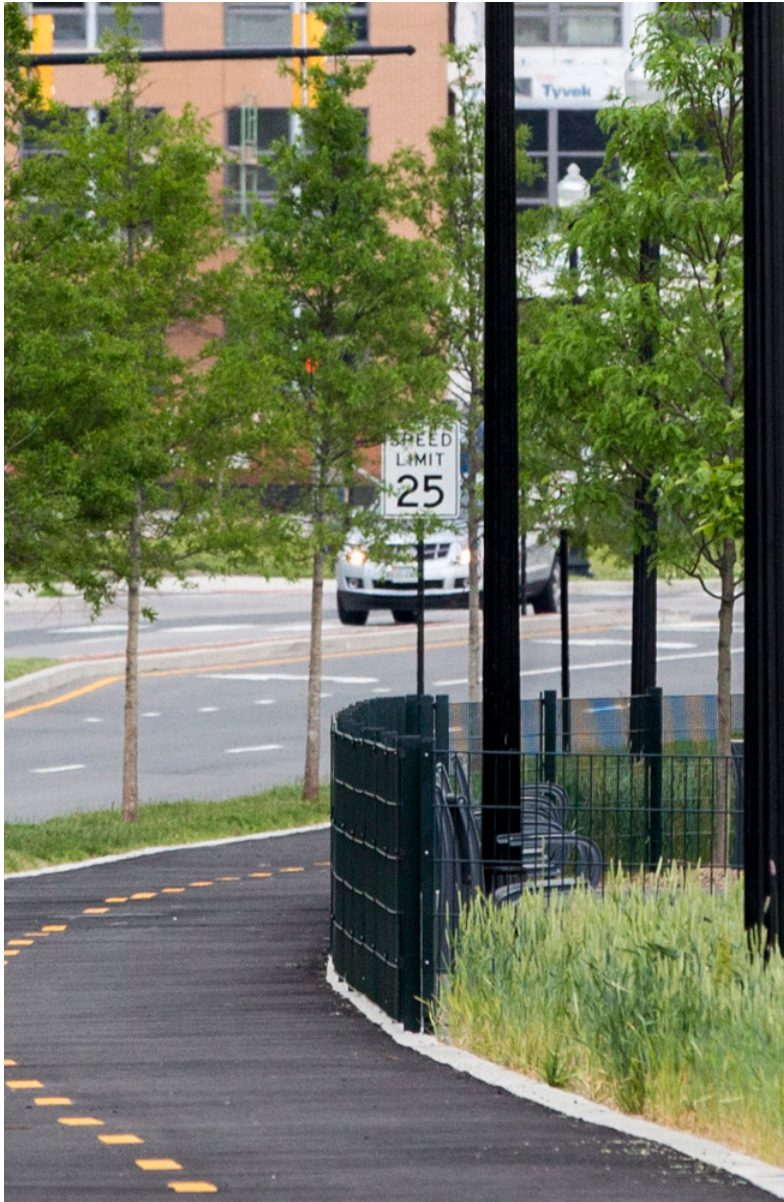


**Figure 1.4**—Illustrations depicting minimum clear widths for pedestrian routes.



**Figure 1.5**—Illustrations depicting minimum dimensions of pedestrian route conditions.





## Chapter 2—Bicycle Facilities

Currently bicyclists access metro stations via dedicated bicycle paths, on-street bike lanes, and/or typical streets. Metro then provides a variety of bicycle parking options that range in scale, security, and capacity. Nearly all stations include bicycle racks. Many include bicycle lockers and Capitol Bike Share stations, and Bike & Ride parking facilities have been built at high priority stations. The diversity in potential bicycle access and parking options allows for tailored design responses to the needs of each station. Increasing bicycle access and encouraging bicycling to Metrorail stations are stated goals of the Metro Board of Directors. To that end, the following guidelines are intended to inform the design of bicycle circulation and parking facilities.

### 2.1 Principles

The following principles should guide the design and planning of bicycle facilities.

- Encourage and provide bicycle connectivity leading to Metrorail stations from adjacent areas.
- Provide clear and intuitive access routes and wayfinding on Metro property.
- Provide safe and direct bicycle access by avoiding unnecessary conflicts with bus movements and cars.
- Minimize bicycle conflicts with areas of high pedestrian activity.
- Provide convenient and secure bicycle parking.
- Design bicycle facilities for cyclists of all experience levels.

## 2.2 Practices

The practices below should be followed to achieve the above principles:

- Bicycle routes should not be less direct than vehicular or pedestrian routes.
- Clear bicycle paths, lanes, or shared lane markers should be provided within the station area.
- Existing roadways should be evaluated for new or upgraded on-street bike lanes.
- Where protected bicycle lanes are not feasible, share lane markers (or “sharrows”) may be considered. These markings are appropriate on roads and adjacent streets with lower traffic volumes and lower traffic speeds.
- Physical separation of bicycle lanes from vehicular lanes using vertical plastic posts, planters, parking stops, parked cars, etc., is strongly encouraged (refer to Federal Highway Administration [FHWA] protected bikeway guide in Appendix A.1.1).
- Curb cuts and crosswalks should be provided at all intersections to facilitate bicycle access.
- Information about bicycle routes in the area should be integrated into station vicinity maps and wayfinding signage.
- Signage directing customers to bicycle parking should be provided.

- Bicycle access should not interfere with pedestrian movements; however, bicycle and pedestrian access paths may be shared if built to sufficient width.
- As with pedestrian paths, bicycle access must not be impeded by street furniture or other obstructions.
- Provide a bike channel alongside stairs, running at the same angle as the steps, for customers to walk a bike along the stairway where appropriate. This bike channel must not preclude stairway compliance with the ADA Standards for Accessible Design.

### 2.2.1 Bicycle Parking and Storage

- Bicycle parking should be located as close as possible to station entrances to encourage cycling and discourage bicyclists from locking bicycles to trees, railings, or other objects closer to the station entrance.
- Bike racks should be located in a well-lit, visible area to discourage theft and vandalism and to provide a safer environment for cyclists (refer to Chapter 8).
- If at all possible, bicycle parking should be located within sightlines from the station manager’s kiosk.
- Bicycle lockers and racks should not be located in areas where they could impede pedestrian movements.
- Bicycle racks should be placed at every station. The exact location and amount of bicycle parking will be reviewed by WMATA staff with planning and operations responsibility for bicycles.

- If there is bike parking located inside of a parking garage provide separate access from the bicycle network to the bike parking area so that bicyclists do not have to travel through the vehicular access or payment area.

### 2.2.2 Bicycle Parking – Secure Bike Parking Facilities or “Bike & Rides”

- Secure Metro bicycle parking facilities, known as “Bike & Rides”, may be placed at certain stations with high levels of bicycle parking demand, or where local security conditions warrant them.
- Bike & Ride stations and Capital Bikeshare docking stations should be located as close to the station entry as possible without impeding pedestrian circulation or views to and from the station entry. They should be located in highly visible locations along bicycle circulation routes to minimize conflicts with other modes of access.

## 2.3 Standards

The following standards apply when implementing the previous practices.

### 2.3.1 Bicycle Access

- Bicycle paths must be designed according to American Association of State Highway and Transportation Officials’ (AASHTO’s) Guide to the Development of Bicycle Facilities and local standards (refer to Appendix A.1.1).

- On-street bike facilities plans must follow National Association of City Transportation Officials (NACTO) and FHWA guidance (refer to Appendix A.1.1).

### 2.3.2 Bicycle Parking and Storage

- At a minimum, each mid line and terminus station must have parking for at least 20 bicycles. The exact type(s) and quantities—uncovered U- racks, covered U-racks, controlled-access bike rooms (Bike & Ride), individually-leased lockers—should reflect the customer needs at each location.
- Racks should be the “inverted U” design in most cases. Additional concepts can be considered by Metro as appropriate.
- Provide cover over bicycle racks with a canopy or structure, when possible, to provide weather protection. For security purposes, bicycle lockers should not be placed below track or mezzanine structures.
- Specific details on the layout of bicycle parking facilities should be designed in accordance with the Association of Pedestrian and Bicycle Professionals’ Bicycle Parking Guidelines (refer to Appendix A.1.1).

### 2.3.3 Bicycle Facilities Site Design Dimensions

Bicycle facility standard dimensions are summarized in Table 2.1.

**Table 2.1**—Bicycle facilities site design dimensions

Facility	Standard
Shared-Use Path (Bicycle & Pedestrian)	<ul style="list-style-type: none"> <li>▪ 12'-0" minimum clear width</li> </ul>
Bicycle Lockers	<ul style="list-style-type: none"> <li>▪ 3'-2" x 6'-0" with a 6'-0" aisle at either end (2 lockers back-to-back)</li> </ul>
Bicycle Parking	<ul style="list-style-type: none"> <li>▪ 3'-0" x 6'-6" with a 6'-0" aisle</li> </ul>
One-Way Separated Bike Lane (On-Road)	<ul style="list-style-type: none"> <li>▪ 5'-0" (min) to 7'-0" (preferred) bike lane plus buffer and vertical separation (see FHWA guide for options)</li> </ul>
Buffered Bike Lanes	<ul style="list-style-type: none"> <li>▪ 4'-0" minimum width plus 3'-0" minimum buffer strip</li> </ul>
Bike Lanes	<ul style="list-style-type: none"> <li>▪ 5'-0" minimum width</li> </ul>
Two-Way Separated Bike Lane (On-Road)	<ul style="list-style-type: none"> <li>▪ 10'-0" (min) to 12'-0" (preferred) bike lane with dashed yellow centerline plus buffer and vertical separation (see FHWA guide for options)</li> </ul>

*Example of Bike Share near Clarendon Metro Station.*



*Example of U-Rack bicycle parking at Dunn Loring Metro Station.*



*Example of Bike Share near Clarendon Metro Station.*



*Example of bicycle lockers at Rockville Station.*



*Example of Bike & Ride parking near Franconia Springfield Metro Station.*

**Figure 2.1**—Photographs depicting various types of bicycle facilities.





## Chapter 3—Bus and Regional Rail Facilities

Transit modes of access to Metrorail include Metrobus, various local bus services, jurisdiction-specific commuter buses, intercity buses, MARC, VRE, Amtrak, streetcar, and future light rail. Most vehicle-based transfers to Metrorail are bus transfers. Metrobus currently operates 325 routes, using 1,500 buses to serve more than 400,000 trips each weekday, and Metrorail trips originating from bus transfers are projected to increase more than any other vehicular mode. Numerous bus routes either terminate or converge at Metrorail stations, making them also logical bus-to-bus transfer locations. Accommodating transfers between all modes is a primary consideration in station access planning.

### 3.1 Principles

The following principles will guide the design and planning of connecting bus facilities:

- Promote safe and efficient transfers between buses and other access modes.
- Provide adequate space for the efficient and safe movement of buses while accommodating the efficient and safe movement of modes ranked higher on the hierarchy. The station area experience should be one of the most predictable parts of a bus route for the operator.
- Prioritize locations for loading and unloading bus transit passengers close to the station entrance.
- Provide visual clarity and clear pedestrian paths for bus passengers walking to and from the station entrance.
- Provide safe, comfortable, and easily maintained waiting areas for bus and transit riders.
- Separate bus circulation from automobile traffic in high bus traffic facilities.

### 3.2 Practices

The practices below should be followed to achieve the above principles:

- With few exceptions, bus facilities should be designed to accommodate capacity demand during the afternoon and evening peak hour period. The afternoon and evening peak hour period is used for planning bus facilities because this is when headways are more frequent and passenger boardings are highest. In addition, bus dwell times may be longer during the afternoon and evening period, when queuing lines tend to form as passengers board buses and pay fares.
- If pedestrian crossings of bus lanes are unavoidable, they should be well-marked, lighted, and clearly identifiable for bus drivers.
- An ADA-accessible route should be provided from all bus loading areas to the station entrance. Level changes between bus-to-Metrorail connections should be minimized to facilitate transfers for persons with disabilities, riders with luggage, and senior citizens.
- Consolidate bus stops in one area of the site to facilitate bus-to-bus transfers.
- Bus traffic should be separated from automobile traffic at stations with a high volume of bus traffic and should be designed to flow in one direction through the station site. Other modes of motorized access should not negatively impact the bus operations.

- Bus priority improvements, such as signal priority or exclusive lanes, which provide faster and more reliable service, should be applied where appropriate. In the absence of bus signal priority, signalized intersections serving bus loops should use short signal cycles to reduce bus delays.

### Consider this...



Consider locating bus loops below grade to improve public space and provide efficient bus-to-rail transfers.

*Example: Union Station, Denver, CO H*

- Ideally, bus platforms should be covered with continuous shelter unless deemed unnecessary by Metro on a case by case basis. Covered walkways should extend to the station entrance via pedestrian pathways wherever possible, should completely cover walkway and bus shelters, and should extend above the front door of the bus.
- Covered walkways are not required to extend over access roads where vertical clearance requirements may make weather protection ineffective. Covered walkways are not required to tie in with the escalator shelters. Covered walkway and shelter supports should not be located where they might impede pedestrian movement.

### 3.2.1 Off-Street Bus Bays

- A one-way loop or bus way is the preferred layout for bus facilities. Two-way circulation should be avoided unless required due to unusual site constraints.
- Lanes for bus layovers should be located in proximity and within view of bus bays to allow layover buses to move to their assigned bay when the bay becomes vacant or at the scheduled boarding time.
- Every bus bay must have a shelter connected to electric power, with real-time customer information, and overhead canopy.

- Buses should be able to re-circulate in proximity of the boarding and alighting area to allow the greatest operational flexibility and allow alighting and boarding at different bays if needed.
- Center island bus bays should be used for facilities with significant bus-to-bus transfers.

### Consider this...



Consider designing bus loops as public plazas with inviting plantings, paving, and pedestrian amenities.

*Example: Gateway Plaza, Los Angeles, CA*

- Pedestrian crossings of the bus lanes should be avoided in most cases. Similarly, bus loops should be designed to avoid disruption of pedestrian desire lines. Pedestrian barriers, such as visually appealing landscaping or fencing, should be provided as a last resort to discourage or prevent crossings at undesignated areas. Barriers should not impede visibility.
- If pedestrian crossings of bus lanes are unavoidable, then crosswalks should be located at the ends of bus arrays, rather than at the middle, where they are less likely to conflict with bus operations.
- Provide protection for pedestrians by using individual shelters or covered waiting platforms directly adjacent to bus travel lanes.

### 3.2.2 On-Street Bus Bays

- On-street bus bays are acceptable for non-terminating through bus routes.
- On-street bus bays should not require buses to “backtrack,” or take an indirect approach to the bus bays, which can delay service, negatively impact schedules, and increase operating costs.
- Bus bays should be designed for passenger boardings and alightings on the right side of the bus, where the bus doors are located.
- Sawtooth bays allow buses to maneuver in and out of the berths easily and safely, and also require significantly less curb space than tangent bays. Tangent bus bays require a significant amount of curb space per bus and are not recommended in most bus loops.
- Angled or diagonal bays, typically used in intercity bus terminals that require back-outs, are prohibited. Private delivery vehicles cannot use bus facilities or bus access roads unless approved by WMATA.
- Bus-to-Metrorail connections should facilitate transfers for persons with disabilities, riders with luggage, and senior citizens.

### 3.3 Standards

The following standards apply when implementing bus facilities.

- Boarding areas must have a level surface and be, at minimum, 5'-0" x 8'-0" in size.
- Typically, terminus stations require all bus bays to accommodate commuter buses which have different geometric requirements. The number of bus bays and the type of bays required will be determined by WMATA. For off-street bus bays, a general rule of thumb is to provide one berth for six buses per hour, with no more than two to three connecting services per boarding berth. The capacity of a berth is generally dependent on bus dwell times.

#### 3.3.1 Off-Street Bus Bays

- Off-street bus facilities with sawtooth bays are mandatory where multiple bus bays are required, and where there are a significant number of terminating routes and bus-to-bus transfers. Bus bays should be designed in conformance with WMATA Standards and Guidelines (see Figure 3.1 for diagram).
- Every bus platform must conform to the ADA Standards for Accessible Design for a level walking surface and accessible path to the station entrance, even when located on a public sidewalk.

#### 3.3.2 Bus Facility Understructure

- In a bus facility located below a structure (parking garage or other enclosure), provide a minimum 14'-6" clear, vertical height to allow adequate free air space above the buses for CNG emissions.
- Requirements for Compressed Natural Gas (CNG)-powered vehicles in the transit facility's understructure should be coordinated with the jurisdictional fire marshal.

#### 3.3.3 Bus Operator Facilities

- There must be an operator's restroom and break room provided outside of the rail station accessible 24 hours per day by bus operators. It must be located within walking distance of the bus loop. Size requirements will be determined by WMATA.
- Requirements for the bus dispatcher's booth and its location will be determined by WMATA.

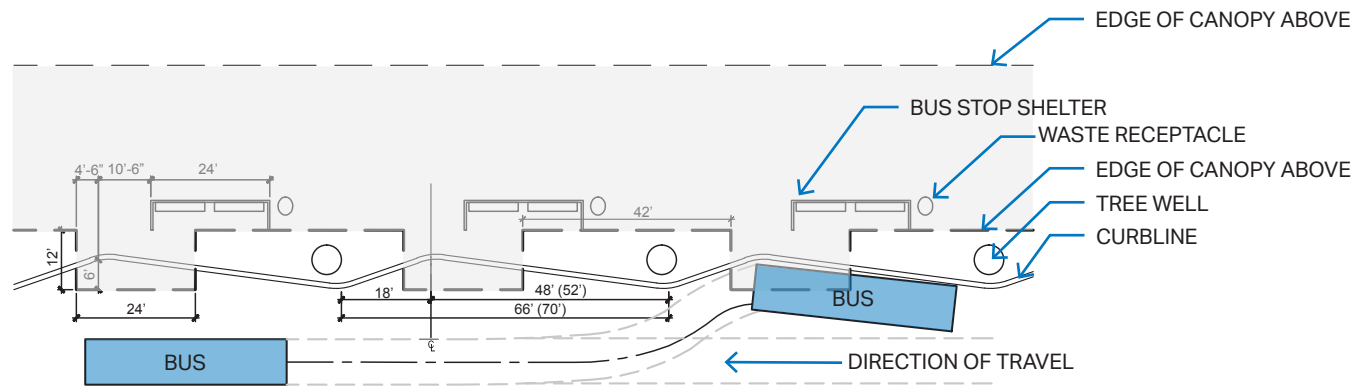
### 3.3.4 Bus Facilities Site Design Dimensions

Bus facility dimension standards are summarized in Table 3.1.

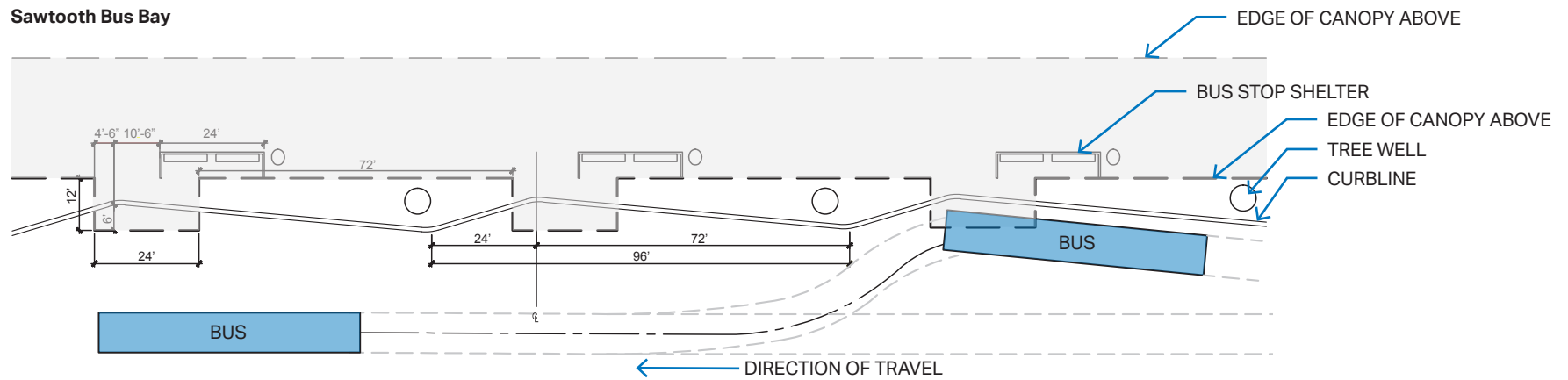
**Table 3.1**—Bus facilities site design dimensions

Facility	Standard
Sawtooth Bus Bays for Standard Bus (40'-0" overall length)	<ul style="list-style-type: none"> <li>66'-0" length with 6'-0" indent as shown in Figure 3.1*</li> </ul>
Sawtooth Bus Bays for Commuter Bus (45'-0" overall length)	<ul style="list-style-type: none"> <li>70'-0" length with 6'-0" indent as shown in Figure 3.1*</li> </ul>
Sawtooth Bus Bays for Articulated Bus	<ul style="list-style-type: none"> <li>96'-0" length with 6'-0" indent as shown in Figure 3.1*</li> </ul>
Tangent Bus Bay (Standard Bus)	<ul style="list-style-type: none"> <li>15'-0" including gutter x 44'-0" + 48'-0" taper at rear of bus bay and 70'-0" taper at front of bus bay</li> </ul>
Tangent Bus Bay (Articulated Bus)	<ul style="list-style-type: none"> <li>15'-0" including gutter x 66'-0" + 48'-0" taper at rear of bus bay and 70'-0" taper at front of bus bay</li> </ul>
Bus Lane Widths	<ul style="list-style-type: none"> <li>15'-0" including gutter for outer through lanes. 13'-0" for inner through lanes if applicable</li> </ul>
Bus Layover Bays	<ul style="list-style-type: none"> <li>Same as tangent bays</li> </ul>
Bus Shelter	<ul style="list-style-type: none"> <li>Minimum equivalent of one 6'-0" x 12'-0" or 6'-0" x 24'-0" shelter per bus bay, as directed by WMATA</li> </ul>
Bus Loop Radii	<ul style="list-style-type: none"> <li>60'-0" outside radius to curb, 45'-0" centerline radius, 30'-0" inside curb radius</li> </ul>
Bus Stop Landing Pad	<ul style="list-style-type: none"> <li>Minimum 90'-0" parallel to road, 10'-0" wide concrete pad in roadway</li> </ul>

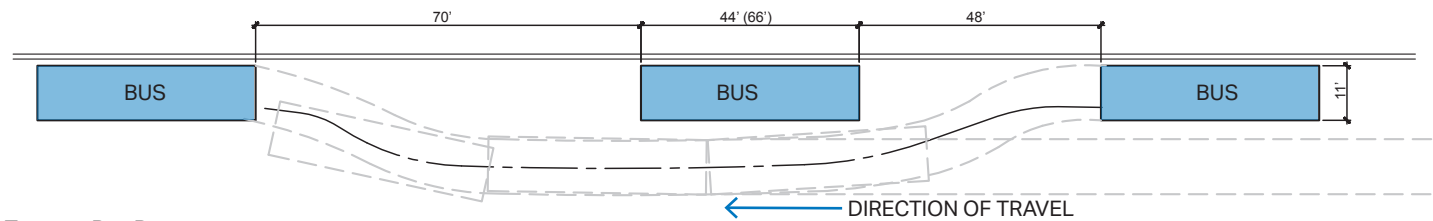
\* Detailed layouts of bus bays must be approved by Metro Bus Planning. Autoturn analysis must be completed to demonstrate conflict free circulation between buses and stationary objects. During the Autoturn analysis, a 1'-0" clearance envelope should be maintained around each bus.



**Sawtooth Bus Bay**



**Articulated Sawtooth Bus Bay**



**Tangent Bus Bay**

**Figure 3.1**—Illustrations depicting dimensions and alignment of typical bus bays.

### 3.3.5 New Transit Services

As WMATA and its partner agencies and jurisdictions expand coverage to meet increased transit demand, new types of service will be introduced. The new services, which may include Light Rail Transit (LRT) Streetcar and Bus Rapid Transit (BRT), will converge at Metrorail Stations and at other multimodal nodes. Integration of these new modes with existing service must be safe, seamless, and clear for customers to easily understand.

This section of the Planning Guide identifies general design criteria for the integration of new modes at existing Metrorail stations, while preserving the existing WMATA Access Hierarchy. The new surface transit technologies offer an increased level of pedestrian accessibility but present safety considerations not encountered with the grade separated Metrorail system. A safe interaction between customers and transit operation is expected at stations for all modes of service and access. When introducing new transit modes and services at existing stations, the safety and mobility for pedestrians is of highest importance. Provisions must be made not to degrade existing service quality and safety of the system. New transit modes and new customer circulation patterns should not negatively impact existing transit service, and station design should provide for seamless and safe interaction among all modes.

The site design should be logical, allowing users to easily understand where in the station they are, and where they need to travel. The location of new modes of transit should be clearly identifiable and should not conflict with existing transit operations and pedestrian movements.

### 3.4 LRT/BRT Principles

The following principles will guide the design and planning of connecting rail facilities:

- At Metrorail stations, the priority should be to reinforce the efficient operation of Metrorail service, including access to and from the station by pedestrians.
- In general, LRT and BRT vehicles should have access priority over regular bus service.
- General vehicular traffic should be prohibited from stopping at LRT and BRT stop locations. Exceptions are buses sharing stop locations with the other modes and emergency or maintenance vehicles.

### 3.5 LRT/BRT Practices

The practices below should be followed to achieve the above principles:

- Light rail transit (LRT) or streetcar platforms and connections to other modes should be designed in accordance with the WMATA Tram/LRT Guideline Design Criteria.
- LRT or BRT platforms must be located where direct visual connection to the Metrorail station and other facilities can be easily made. Customers should be able to see the starting location of the next leg of their trip, whether it be by transit or another mode.
- Platforms should be located and integrated into the existing station site to preserve the established WMATA Access Hierarchy.

- The new platforms should be located as close to transferring modes as possible to reduce walking distances and enhance transfers between the transit modes.
- The new platforms and associated pedestrian movement should not negatively impact existing traffic through the station site from other modes: pedestrian, bicycle, bus, Kiss & Ride, and Park & Ride.
- New transit service at existing Metrorail stations should operate on exclusive, dedicated guideways or roadways where feasible.
- LRT or other rail connections to Metrorail should be located to facilitate a convenient connection to the station entrance. Pedestrian crossings of vehicular travel lanes between transit loading and unloading areas or the station entrance should be avoided.
- Covered walkways from connecting rail to the station entrance should be provided wherever possible.

### 3.5.1 Station Platforms for LRT and BRT

Platforms should be designed to be accommodating to waiting customers and pedestrian movement in both directions across the platform. The platform design should clearly delineate public and unauthorized areas such as the edge of platform, the transit guideway, and areas designated for WMATA staff only. The platform area should be visually distinguishable and easily accessible from other areas of the station site. The following criteria provide direction for appropriate platform design.

(For additional platform design criteria, refer to WMATA Tram/LRT Design Criteria, Appendix A.1)

- Platforms should be integrated into adjacent paving and streetscape features to avoid drainage conflicts.
- The vertical and horizontal gap distance between the platform and both planes of the car door sill should be within the tolerance allowed in the *FTA Accessibility Handbook for Transit Facilities*.
- The paving finish of platforms should be clearly distinguished from the surface treatment of the transit guideways so the path of LRT and BRT vehicles is recognizable.
- Platform fixtures and furniture should not conflict with the flow of passengers on platforms and should not be located within pedestrian crossing areas.
- Catenary poles located in platform or pedestrian areas such as pedestrian plazas should be aesthetically pleasing and recognizable to avoid incidental contact. The bases of catenary poles can be surrounded by planted vegetation or planter boxes, helping the poles blend with the pedestrian fabric of the station and guiding pedestrians around poles.

### 3.5.2 Pedestrian Safety at LRT and BRT Stations

Customer access to LRT or BRT may require crossings of active transit guideways to reach platforms, especially at station sites where exclusive guideways are not feasible. At pedestrian crossings of LRT tracks, potential conflicts between pedestrians and transit vehicles are a concern. To mitigate and reduce these conflicts, customer crossing control can be implemented through crossing design and through an array of active and passive safety treatments.

#### Pedestrian Crossing Design and Location

Pedestrian crossings should be designed to be easily identified by pedestrians and transit operators. Pedestrian crossings channel pedestrian movements to specific locations where the pedestrian can be warned of approaching transit vehicles. They also create specific locations where the transit operator can anticipate that pedestrians will cross the guideway. The following are criteria for the design and location of pedestrian crossings:

- Distinct pedestrian crossings should be located at both ends of the LRT or BRT platform. Crossings should be designed to encourage pedestrians to cross the guideway at these designated locations.
- Crossings should be level where possible to accommodate ADA needs. Ramps designed according to ADA specifications should be included to transition the platform elevation to that of the crossing elevation and elevation of surrounding pavement surfaces.

- Crossings should be distinguishable by all pedestrians according to the senses of vision, hearing, and touch. Crossings should also be distinguishable by the transit vehicle operator. The following subsection describes safety treatments that can assist in making crossings more distinguishable by both pedestrians and vehicle operators.

#### Pedestrian Safety Treatments

Safety treatments can improve the safety of pedestrian circulation areas and enhance the effectiveness of pedestrian facilities. The effectiveness of each treatment is site specific, and is based on key characteristics such as transit operations, physical characteristics of the site, and pedestrian volume and circulation. Situations that warrant protection include:

- High transit speed or frequencies
- Limited sight distance of approaching trains
- Locations with intermittent surges of pedestrian movement

Heavy pedestrian volumes warrant protection unless transit speed is low and sight distance sufficient. Potential conflicts between pedestrian activity and transit operations (along the line or at stations) are prevalent in urban locations. Pedestrian safety treatments are also necessary in these areas. General types of urban site conditions for LRT and BRT transit operations include pedestrian plazas, exclusive guideways, and curbside guideways.



**Figure 3.2**—Photograph depicting various pedestrian safety measures at LRT Station.

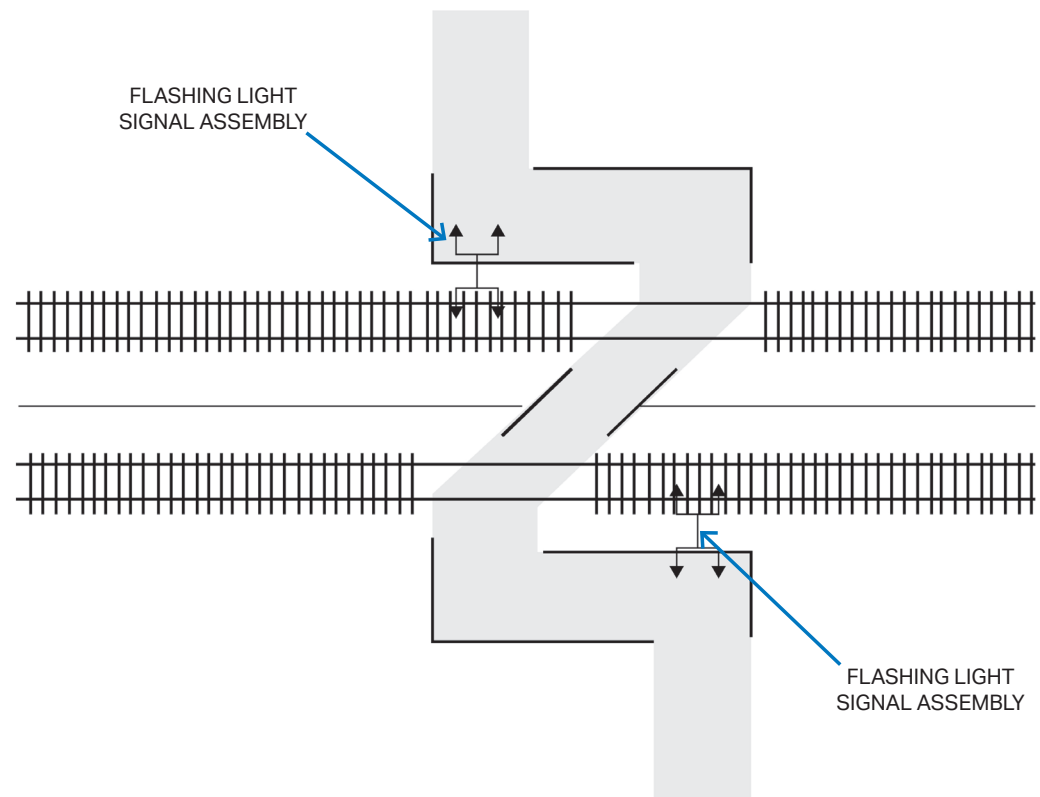
### 3.5.3 Inventory of Pedestrian Safety Treatments

This section provides an inventory of pedestrian safety treatments used in connection with transit operations. The selection of treatments applied at each location should reflect specific site conditions and the nature of conflicts at that site. Types of safety treatments are categorized as Passive Safety Treatments (treatments not activated by approaching trains) and Active Safety Treatments (treatments activated by approaching trains). While this inventory is not exhaustive, it includes treatments that are commonly used by transit agencies in the United States. A description for the use of each treatment and general criteria for the appropriate application of each treatment are provided.

#### Passive Safety Treatments

- **“Stop Here” Pavement Markings** – Pavement markings indicate that pedestrians should stop behind the mark. Markings are used at crossing locations to alert pedestrians to proximity to the guideway and provide clearance for approaching transit.
  - **Warning Signage** – Signage used to direct and remind pedestrians to keep away from potential hazards and exercise vigilance when approaching the guideway. Such signage is usually located in the vicinity of the guideway.
  - **Tactile Warnings** – Installed as part of pavement finishes at crossing locations and alongside the guideway where pedestrians approach, such as at the edge of the platform. Tactile warnings alert pedestrians to the proximity of the transit guideway.
- **Swing Gates** – Used at entrances to platform areas to slow pedestrians who are moving between platforms and the guideway. These are usually non-motorized mechanical gates. Some swing gates can incorporate warning signage.
- **Physical Channeling** – Using railings, fencing, curbs, landscaping, or other tools to control pedestrian movements over designated crossings of the guideway. Allows transit vehicle operators to anticipate where pedestrians will cross the guideway.
- **Separation Fence** – Fencing used to restrict unauthorized access to or across the guideway. Can be applied to the median of the guideway or between the guideway and pedestrian areas.
- **Pedestrian Barriers** – Similar to channeling, barriers can be used at platform entrances to guide pedestrians to the proper platform access and guideway crossing locations.
- **Planted Vegetation** – Used at strategic locations along the transit alignment to restrict unauthorized access to or across the guideway. Planted vegetation can be applied on both ends of the platform to discourage crossing in front of a departing or arriving transit vehicle.

- **Pedestrian Z-Crossings** – Designed as gated entrance ways, pedestrian z-crossings are used at mid-block street crossings. The crossings channelize pedestrians to face the direction of oncoming transit vehicles before stepping into the guideway. Z-Crossings guide pedestrians across the guideway in a slight diagonal orientation partially facing the direction of oncoming transit on the other side of the guideway. These crossings should comply with ADA standards that govern path-finding and the incorporation of active safety treatments such as audible and visual warning devices and passive safety treatments such as tactile warnings.



**Figure 3.3**—Illustration depicting typical pedestrian Z-Crossing layout.

**Active Safety Treatments**

- **LED Flashing Train Warning Signs** – Used at signalized intersections to warn pedestrians and motorists of approaching transit vehicles.
- **Pedestrian Flashing Lights and Audible Warning Device in Gated Crossing Controlled Environments** – Used at crossings and specifically oriented toward pedestrian crossing areas to warn pedestrians against crossing the guideway of an approaching transit vehicle.

Pedestrian crossing techniques and the safety treatments to be used must be chosen in light of the specific operating conditions present at each crossing location.

- **Pedestrian Plaza conditions** – The LRT system operates through a plaza without grade separation or separating barriers.
- **Curbside conditions** – The LRT system operates along a multi-modal street where the stops occur along the curbline.
- **Exclusive guideway conditions** – The LRT operates within its own dedicated path of travel not shared with other vehicles.

**Consider this...**

Consider the flexibility and amenities of public spaces that accommodate transit circulation without separating barriers.




*Example: Civic Space Park, Phoenix, AZ*

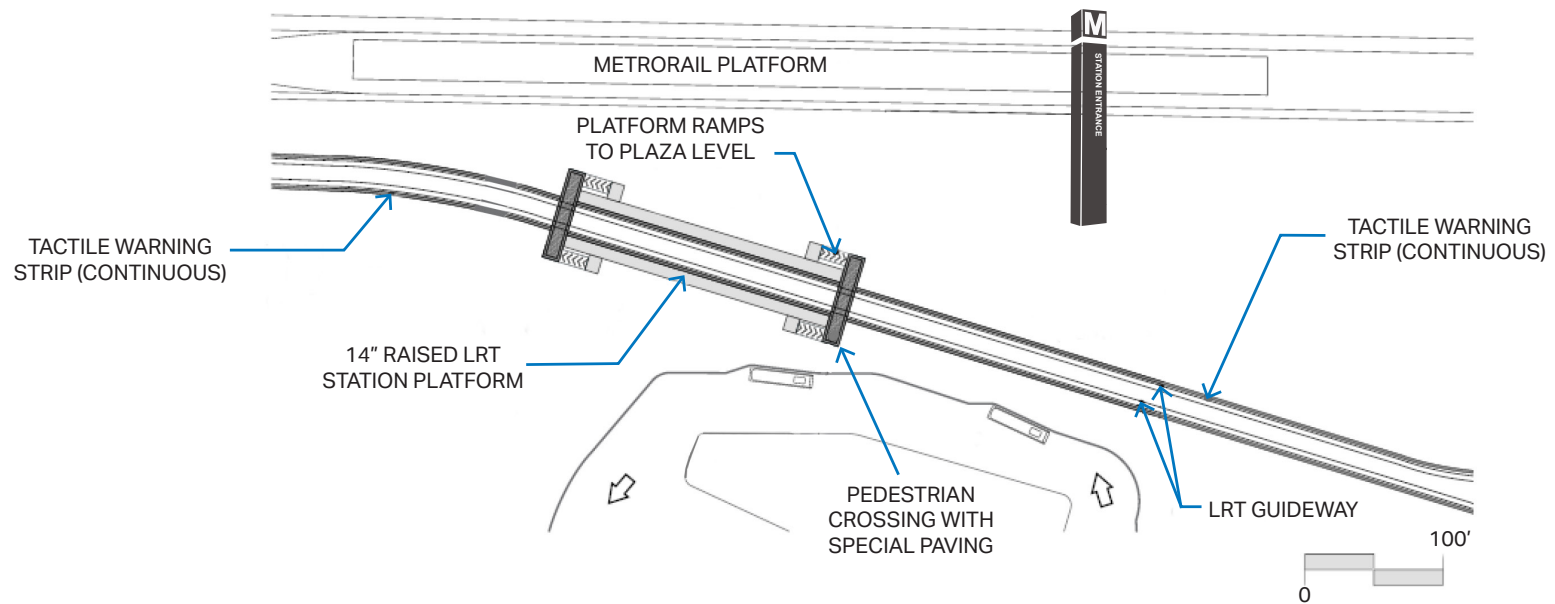
**Table 3.2**—LRT Operating Conditions

Table 3.2 provides a summary of general criteria regarding the application of each recommended safety treatment and the general urban site condition under which it can be applied.

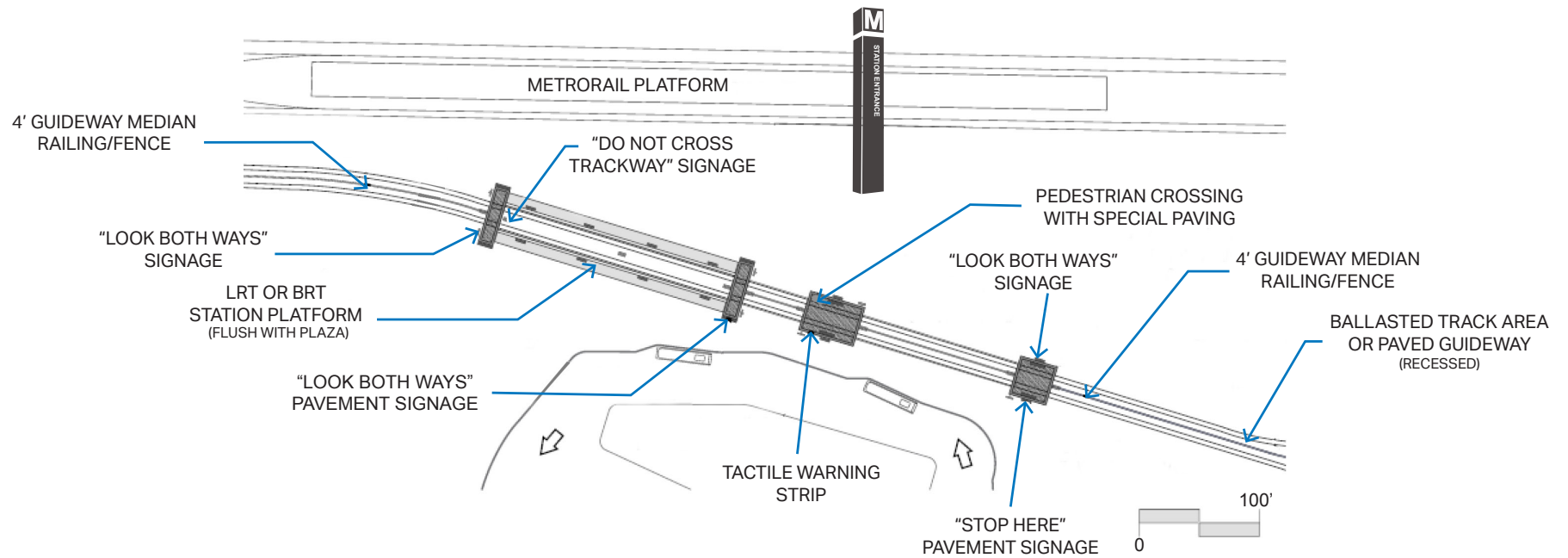
	Safety Treatment	Pedestrian Plaza	Curbside	Exclusive Guideway	Goal
Passive Strategy Treatments	1. "Stop Here" Pavement Markings				Warn pedestrians of the safe location to stop away from transit guideway
	2. Warning Signage				Warn pedestrians of hazards and increased vigilance when in close proximity to transit guideway
	3. Tactile Warnings				Warn pedestrians of the immediate proximity of transit guideway
	4. Swing Gates				Slow pedestrians entering platform area and create awareness of adjacent transit operations
	5. Channeling				Control pedestrian movements to safe and predictable locations to cross the guideway at authorized locations
	6. Separation Fence				Restrict unauthorized access to or across the transit guideway
	7. Pedestrian Barriers				Slow pedestrians entering platform area and create awareness of adjacent transit operations
	8. Planted Vegetation				Separate pedestrians from transit guideway to prevent unauthorized access
	9. Pedestrian Z-Crossing				Slow pedestrians entering authorized crossings of the transit guideway and create awareness of approaching transit vehicles
Active Safety Treatments	10. LED Flashing Train Warning Signs				Separate pedestrians from transit guideway to prevent unauthorized access
	11. Pedestrian Flashing Lights and Audible Warning Device in Gated Crossing Controlled Environments				Slow pedestrians entering authorized crossings of the transit guideway and create awareness of approaching transit vehicles

	Treatment Applied Depending on Site-Specific Conditions		Treatment Should Apply		Treatment Not Required
-------------------------------------------------------------------------------------	---------------------------------------------------------	-------------------------------------------------------------------------------------	------------------------	---------------------------------------------------------------------------------------	------------------------



**Figure 3.4**—Illustration depicting safety treatments with minimal control of pedestrian movement.



**Figure 3.5**—Illustration depicting safety treatments with enhanced control of pedestrian movement.





## Chapter 4—Shuttle Facilities

In the past decade, WMATA has experienced a significant increase in shuttle van and shuttle bus activity at Metrorail stations throughout the system. These services benefit the system, as they effectively extend transit coverage, strengthen ridership, and reduce dependency on single-occupancy vehicle access to the station. However, the physical dimensions and operational characteristics of these vehicles can cause challenges at peak periods for some stations because in many cases they share space with other access modes. At stations where shuttles frequently utilize the Kiss & Ride, conflicts arise that result in congestion and shuttles loading and unloading in travel lanes or parking spaces.

Many schedule-based shuttles at WMATA stations serve apartments, offices, universities, and hospitals. WMATA can authorize shuttles to access underutilized bus bays if the shuttle operator is approved by the Office of Bus Planning and can comply with Metro's insurance requirements. However, the majority of shuttles are smaller, less than 30' in length, and utilize the Kiss & Rides because they are not permitted to use bus bays. Many of these shuttles serve residential communities that are located outside of a convenient walking distance from the station. Previous WMATA studies have suggested management techniques that can help ease conflicts with shuttle vans (see *Shuttle Services at Metro Facilities*, WMATA, 2011, in Appendix A.1.1), but the physical station area design can also play a role. These riders are an important part of the system, and like all modes, station area planning must adapt to and anticipate their needs to the extent possible.

### 4.1 Principles

The following principles apply when planning and designing space for unscheduled shuttle services:

- Avoid congestion within Kiss & Ride facilities that could negatively impact other modes.
- Maintain convenient and safe operations for shuttle systems.
- Allow for simple retrofitting of existing facilities to accommodate shuttle systems.
- Create or retrofit facilities that are adaptable to various parking arrangements and surrounding land use changes.

### 4.2 Practices

The practices below should be followed to achieve the above principles:

- Consider the station's land use context, including proximity to apartment complexes, condominiums, and other high-intensity residential areas that will likely create a demand for shuttle services for their own transportation demand management.
- Consider station typology, as shuttle facilities are most needed at terminus and mid-line stations.
- Encourage quick turnover of shuttle spaces near the station entrance, and use satellite layover spaces nearby whenever possible.

- If space permits, consider creating shuttle layover spaces within Kiss & Ride facilities. Consider satellite layover spaces nearby for waiting shuttles.
- Create more Kiss & Ride curbside space, and consider relocating taxi stands outside of Kiss & Rides to accommodate dedicated shuttle facilities.
- Consider curbside shuttle bus pick-up and drop-off on adjacent roadways.
- Consider reducing non-ADA short-term parking to increase shuttle van spaces at stations with high shuttle activity.

### 4.3 Standards

The following standards apply when designing shuttle bus accommodations at WMATA facilities:

- Shuttle vans that are less than or equal to 30'-0" in length should be accommodated in the Kiss & Ride area without a permit. Shuttle vans with a high frequency may apply for a permit to utilize the bus bays.
- Shuttle buses that are greater than 30'-0" in length may be accommodated in the bus bay subject to obtaining appropriate permits from Metro.
- Shuttle van spaces should measure 8'-0" in width x 35'-0" in length.



**Figure 4.1**—Photograph of permitted Shuttle bus utilizing bus bay.





## Chapter 5—Vehicular Drop-Off/ Pick-Up Facilities, Car Share, and Ride Hailing

Within the Metro system, ride-hailing, car-share, and vehicular drop-off/pick-up facilities are accommodated simultaneously by Kiss & Ride facilities. Kiss & Ride facilities typically include taxi stands, motorcycle parking, private shuttle vans (see chapter 4), short-term parking, and parking for car-sharing vehicles. The combination of multiple travel modes and significant pedestrian activity in Kiss & Ride areas can result in a number of site challenges, including congestion at peak periods, competition for curbside space, and undesirable conflicts between pedestrians and moving and parked vehicles.

The size and orientation of the Kiss & Ride, as well as its circulation patterns and allocation of space among modes, can dramatically impact the operational success of the facility. It is important to note that there is not a one-size-fits-all answer to Kiss & Ride facility design. Many factors must be weighed when determining the case-by-case design priorities for a particular station, including access mode splits, peak hour ridership volumes, physical site constraints, surrounding land use changes, and changing rider preferences. As land use around stations become more urbanized, how the Kiss & Ride function is accommodated should be evaluated.

## 5.1 Principles

The planning and design of Kiss & Ride facilities should include the following principles:

- Consider the station type and land use context in the specific design priorities for a given station.
- Design Kiss & Ride facilities for the intuitive and safe flow of vehicles and pedestrians.
- Design Kiss & Ride facilities to encourage turnover and facilitate quick access to and from the station.
- Design for a Kiss & Ride facility capacity that reflects station access mode-share goals.
- Design Kiss & Ride facilities through a collaborative process with WMATA staff to optimize the functionality, develop its circulation patterns, and determine the most efficient allocation of space within the facility's footprint.
- The Kiss & Ride facility should be restricted to terminus and mid-line stations. In urban areas with higher density, the Kiss & Ride function may be designated with a passenger drop-off lane located on an adjacent access road or municipal street.

## 5.2 Practices

The following Kiss & Ride facility design practices should be followed to achieve the previously mentioned principles:

- The Kiss & Ride area functions as a drop-off/pick-up/short-term parking. Access to the Kiss & Ride facility should be separated from the entrance gates to the Park & Ride area and bus loops.
- Except for buses, no vehicular circulation should be located closer than the Kiss & Ride to the station entrance.
- Kiss & Ride should be designed for one-way circulation and recirculation without leaving the station area.
- Curb-side drop-off and pick-up length should be maximized to the extent practical.
- The Kiss & Ride's parking spaces should be oriented for angled pull-through access where practical.
- Provide clearly designated spaces that differentiate between user types, including shuttle buses, traditional taxis and ride-hailing, car-sharing, and other types of passenger drop-off/pick-up users.
- Short-term parking is permitted during designated hours, as stipulated by WMATA policy.
- Transportation network companies, such as Uber, Lyft, etc., should function as private vehicles within Kiss & Ride areas.

- Micro-transit services (privately owned transit systems such as Chariot, Bridj, Via, Lyft, Shuttle, etc.) should function as shuttle van vehicles within Kiss & Ride areas.
- Kiss & Ride facilities located in parking structures must provide separate access and egress from Park & Ride vehicles.
- Kiss & Ride facilities may be considered on a case by case basis along the local perimeter roadway system subject to coordination with local jurisdictions and local enforcement.

Table 5.1 describes the facilities that must be accommodated within Kiss & Ride areas, compared to those which could be located in an alternate location.

**Table 5.1**—Kiss & Ride access mode requirements

Access mode	Must be accommodated within Kiss & Ride or on adjacent street*	Can be accommodated inside or outside Kiss & Ride
Vehicular drop-off/pickup	X	
Shuttle van** drop-off/pickup		X
Car sharing parking		X
Taxi stand		X
Motorcycle parking		X
Short-term parking		X
Maintenance vehicle parking	X	

\* Use of adjacent streets must be coordinated with local jurisdictions.

\*\*Refer to Chapter 4 for shuttle van considerations.

A toolbox of individual options is available to help WMATA, local jurisdictions, and joint development partners develop appropriate, approved design and policy options for each Kiss & Ride. These options should be applied based on planned modal access, flexibility, surrounding land use, station typology, and other relevant factors.

The following strategies can be considered on a case-by-case basis:

- Station modal access studies, in coordination with jurisdictions if applicable, should be used to identify future design and capacity needs, based on projected ridership and station-area land use, including the needs of shuttle buses, driver-attended parking, taxis, ride-hailing, car-sharing, autonomous and/or connected vehicles, and the needs of other types of passenger drop-off/pick-up users.
- Conduct customer surveys that analyze ride-hailing and personal auto trips, determine Metrorail station by access distance, direction of travel relative to home and work, and surrounding land use.
- Provide a framework for identifying transportation demand management requirements for jurisdictions within the station’s service area, and a process by which the jurisdictions can work with WMATA to best address shuttle bus circulation and other Kiss & Ride access issues.
- Provide more access points for pedestrian and bicycle users from neighborhoods surrounding the station, including safe and signalized pedestrian and bicycle trail access.

- Consider separating areas for shuttle bus entrances, egress, layover, and circulation points from other uses.
- Where space allows, consider providing dedicated access points from adjacent streets for vehicles using Kiss & Ride functions.
- Consider providing drop-off and pick-up locations on adjacent streets outside of WMATA property, and develop off-property points in coordination with the local jurisdiction.
- Analyze and develop more efficient signal timing into and around the station area to further reduce congestion for both the jurisdiction and WMATA.
- Consider providing a short-term vehicle parking area separate from the Kiss & Ride, similar to airport “cell phone lots,” for vehicles waiting to pick up passengers. This facility should be located away from the station entrance and used by ride hailing services or others contacted by phone to come pick up passengers in the Kiss & Ride.

### 5.3 Standards

The following standards apply when designing Kiss & Ride facilities:

- Refer to Table 5.3 for parking space dimensions
- Kiss & Ride facilities where private shuttle buses travel beneath a structure should have a 16'-9" minimum vertical clearance.
- Kiss & Ride facilities should include the following provisions for people with disabilities:
  - Accessible passenger loading zones with an access aisle and curb ramps that meet ADA Standards for Accessible Design for curb cuts, including a 1:12 slope and side flares with 1:10 slopes.
  - Accessible passenger loading zone with an access aisle and curb ramps for the front taxi space.
  - The number of accessible spaces with accessible paths should be determined by the governing building code or by ADA Standards for Accessible Design.
  - The number of additional curb cuts should be determined by maintaining accessible routes and by the governing jurisdiction’s building code.

- Accessible automobile and van spaces should be located in each Kiss & Ride facility, and their number is to be determined by the governing building code or the ADA Standards for Accessible Design. These spaces should be located closest to the station entrance. Each lot or facility should provide the number of spaces required to meet applicable code or the ADA Standards as an independent facility.
- Provide one bus shelter per 100 Kiss & Ride spaces for waiting. Locate the shelter adjacent to the taxi stand pick-up area.
- Provide a minimum five percent of pervious area in the Kiss & Ride facility, which may include sidewalk planter boxes for street trees.
- In accordance with WMATA Board of Directors Resolution 1972-27, adopted 16 November 1972, parking areas for more than five vehicles should be effectively screened from surrounding development on each side of the property adjoining or facing a residential zone or institutional premises, unless the parking areas are already effectively screened by a natural terrain feature, railroad tracks on elevated ground, a change in grade or other permanent natural or artificial screen, or separation by a road with a 120-foot-wide or greater right-of-way.

The following quantitative analysis should aid in determining the Kiss & Ride's optimal size and the allocation of parking facilities. These metrics are intended to inform collaborative processes with WMATA staff. The formula is not intended to be a requirement, but rather to serve as guidance. The formula takes into account access modes at an individual station. Peak hour Kiss & Ride arrivals are determined by multiplying the number of peak hour exits at a station by the percentage of passengers who access the station by Kiss & Ride.

$$(2)(\text{Kiss \& Ride Customers/Trains per Peak PM Hour}/0.85) = \text{Estimated Kiss \& Ride Spaces}$$

For example:

*At the Dunn Loring-Merrifield station, there are 1,085 exits in the PM peak hour. Using a 17 percent Kiss & Ride mode share, approximately 185 customers would be picked up in the PM peak hour. There are 15 trains arriving in the peak hour. The number of estimated Kiss & Ride spaces is determined by the following equation:*

$$(2)(185/15/0.85) = 29 \text{ Estimated Kiss \& Ride Spaces}$$

The suggested quantity of Kiss & Ride spaces include ADA Standards-compliant, driver-attended, and short-term parking. This number excludes curbside spaces for automobile pick-up and drop-off, taxi queuing, shuttles, and spaces for motorcycles.

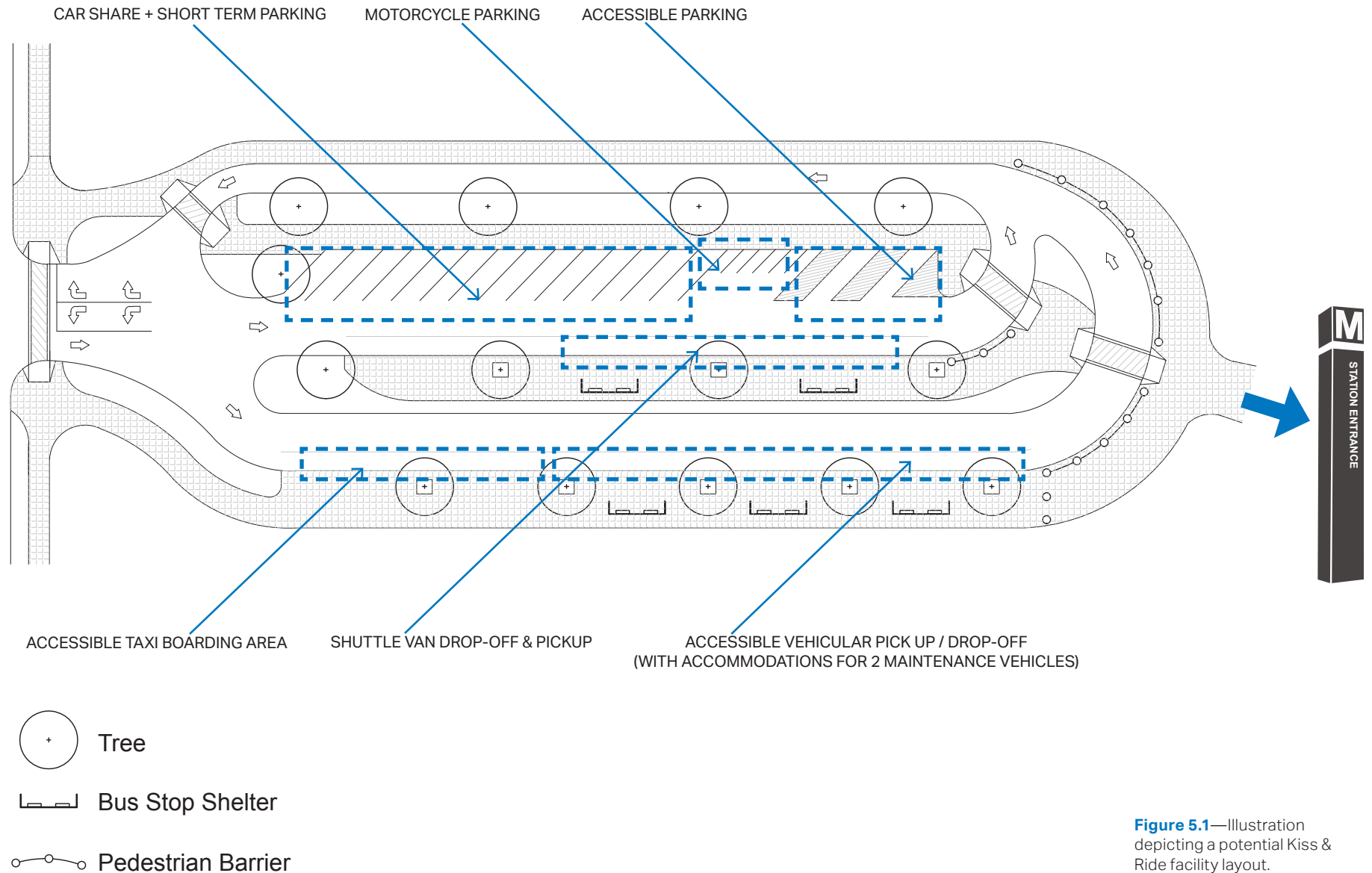
Table 5.2 summarizes parking space allocation recommendations, and Table 5.3 summarizes their standard dimensions.

**Table 5.2**—Parking space allocation guidance

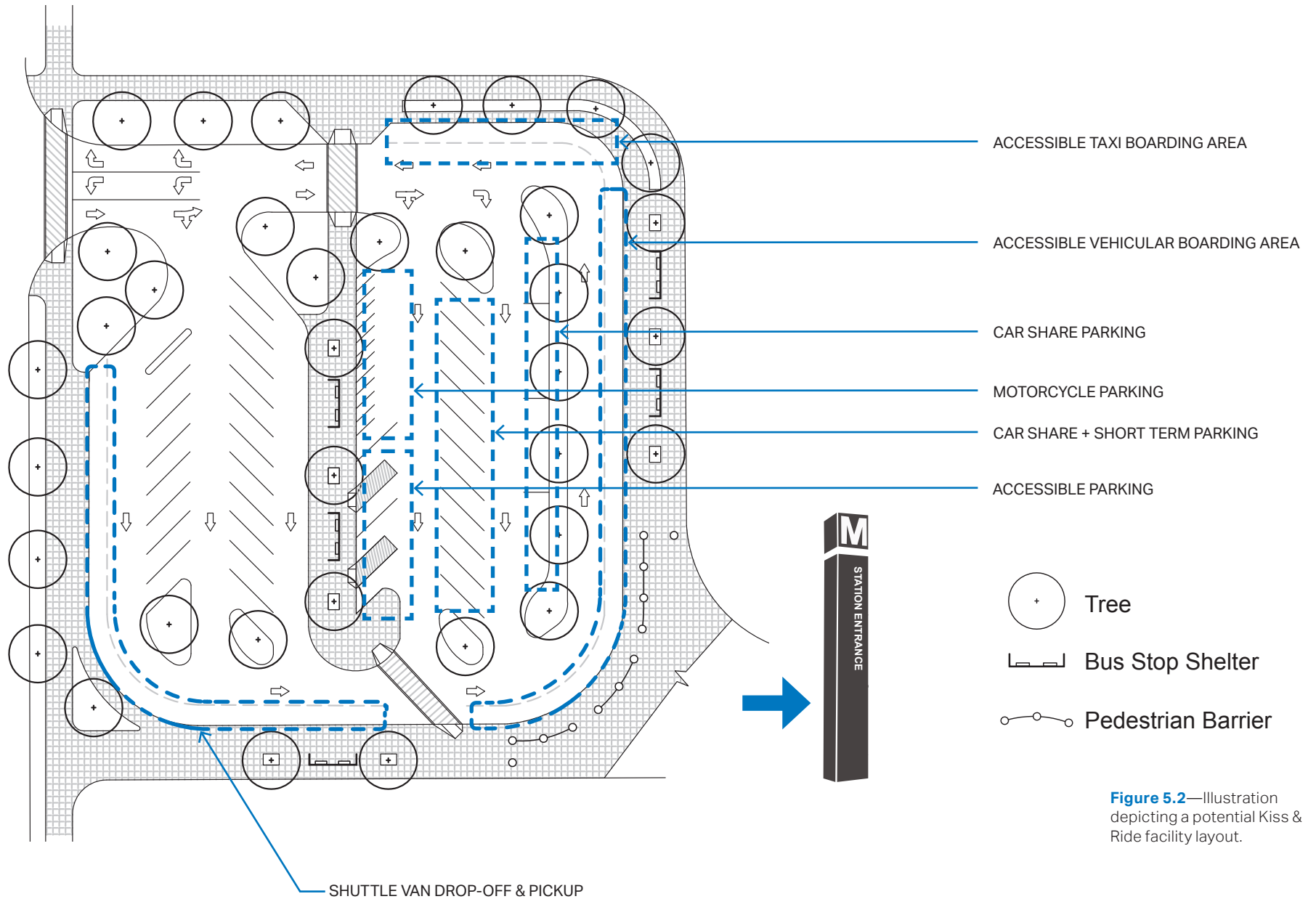
	Included in suggested # of spaces	Estimated Space Allocation
Driver-Attended and ADA Spaces	Yes	<ul style="list-style-type: none"> <li>Half of the number of Kiss &amp; Ride spaces suggested should be dedicated for driver-attended spaces, including accessible spaces</li> <li>Some of the driver-attended parking should be for dual-use with metered spaces and posted for short-term parking</li> </ul>
Short-Term Parking	Yes	<ul style="list-style-type: none"> <li>Half of the number of Kiss &amp; Ride spaces suggested should be dedicated to exclusive short-term, metered parking</li> </ul>
Curb-Side Spaces	No	<ul style="list-style-type: none"> <li>Provide one curbside space for every six Kiss &amp; Ride spaces suggested (rounded to the nearest whole number)</li> </ul>
Taxi Queue	No	<ul style="list-style-type: none"> <li>One curbside space for every six Kiss &amp; Ride spaces suggested (rounded to the nearest whole number)</li> </ul>
Private Shuttles	No	<ul style="list-style-type: none"> <li>Provide a minimum of one curbside space for every 10 Kiss &amp; Ride spaces suggested (rounded to the nearest whole number)</li> </ul>
Motorcycles	No	<ul style="list-style-type: none"> <li>Provide one space for every five Kiss &amp; Ride spaces required (rounded to the nearest whole number)</li> </ul>
Maintenance vehicles	No	<ul style="list-style-type: none"> <li>Provide accommodations for two maintenance vehicles along the curbside drop-off lanes for ease of access to station</li> </ul>

**Table 5.3**—Parking space dimensions

Motorcycle Parking Spaces	4'-0" X 8'-0" (located adjacent to Kiss & Ride)
Kiss & Ride Curb-Side Pick-Up/ Drop-Off Lane	<ul style="list-style-type: none"> <li>Automobile spaces: 8'-0" x 30'-0"</li> <li>Shuttle van spaces: 8'-0" x 35'-0"</li> <li>Taxi spaces: 8'-0" x 22'-0"</li> </ul>
Kiss & Ride Parking Spaces	<ul style="list-style-type: none"> <li>ADA-compliant and driver-attended: 9'-0" x 18'-0" (45 degree) with 8'-0" wide access aisle</li> <li>Short-term: 8'-6" x 18'-0" (45 degree or 90 degree)</li> <li>Shuttle bus layover/non-curb parking space 8'-0" x 35'-0"</li> </ul>
Perpendicular ADA-Accessible Spaces	8'-0" X 18'-0" (perpendicular parking) with 24'-0" wide access aisles, with adjacent 5'-0" accessible aisles for autos and adjacent 8'-0" accessible aisles for vans
Maintenance Spaces	Metro service vehicle spaces: 10'-0" x 18'-0"



**Figure 5.1**—Illustration depicting a potential Kiss & Ride facility layout.



**Figure 5.2**—Illustration depicting a potential Kiss & Ride facility layout.



**Figure 5.3**—Photograph depicting multiple circulation modes converging at Kiss & Ride drop off area.



## Chapter 6—Vehicular Parking and Circulation

Park & Ride facilities include all-day parking for private vehicle access to Metrorail for persons who live beyond a reasonable walking distance from the station, or who are unable to utilize other transit modes. Park & Ride is considered an important transit mode share and should be accommodated as appropriate. WMATA will determine the required number and layout of spaces in a new or reconfigured parking lots based on the following considerations: revenue neutrality, existing community dynamics, capacity of the lot, the development context at other stations, and distance to the station entrance.

### 6.1 Principles

Ensure that vehicular parking design contributes to an efficient, intuitive, and safe circulation system.

- Design vehicular circulation to accommodate automobile access while prioritizing higher-ranking access modes and minimizing pedestrian/vehicular conflicts.
- Design vehicular ingress and egress access points with all aspects of station access and hierarchy in mind.
- Provide appropriate ingress and egress to facilitate high vehicle volumes at peak hours.
- Provide facilities to support public safety and protection of personal property.
- Mitigate the affects of impervious coverage by promoting low-impact development and runoff management.



The following guidelines and criteria are provided to ensure that adequate access is provided to Park & Ride facilities at Metrorail stations.

## 6.2 Practices

The practices below should be followed to achieve the above principles:

- Park & Ride facilities should be located within a convenient walking distance to the station entrance.
- Driving aisles should be aligned in the direction of the station entrance, so that pedestrians do not have to walk between parked cars.
- ADA-compliant parking in the Park & Ride facilities should be located closest to the station entrance, and should be connected to the station via an accessible path. Walkways should be carefully planned so that persons using accessible parking will not need to navigate behind parked cars to reach entrances, ramps, walkways, or elevators.

### 6.2.1 General

- The successful functioning of the station site facilities depends on good access for vehicles to the existing roadway network. Traffic impact studies should be prepared for all major changes and development projects that may affect access routes in the station area.
- Automobile access to Metrorail stations should be provided from collector streets or access roads that intersect with arterial roadways. When it is necessary

to provide direct access to an arterial route, access points should be spaced properly to avoid long queues from nearby intersections or interchanges. Avoid increasing congestion on adjacent arterial roadways or freeways whenever possible.

- Station access roads should connect to the existing arterial street system, and if possible, to the limited access highway system as well.
- Where access roads have a combined use that mixes bus and automobile traffic, entrance and exit conditions from each facility should be studied to minimize turning movement conflicts.
- Vehicular access to the station site that requires or increases travel through primarily residential or neighborhood streets should be avoided.
- Existing road networks, traffic patterns, traffic signals, and pedestrian and bicycle desire lines should be evaluated, and all proposed road improvements by others should be identified at the outset of design.
- Connections should be designed to prevent encroachment of bus turning movements into opposing traffic lanes.
- Intersections should have safe, direct pedestrian crosswalks. Signalization is strongly recommended at pedestrian access routes that cross major streets.
- In addition to transit vehicle access, access for station facility, maintenance, police, and emergency vehicles should also be considered. Coordinate emergency and maintenance vehicle access requirements with the local jurisdictional fire marshal and with WMATA.

### 6.2.2 Access Points

- Coordinate all proposed access road intersections and entrances to Metro facilities with state and local authorities when planning to provide dedicated routes from adjacent major roads.
- Design access road intersections with exit lanes with tight curb radii to encourage slower turns and deter noncompliance with stop controls.
- Vehicle access points should be coordinated with pedestrian and bicycle access points in a manner that maximizes opportunities to provide supportive infrastructure, such as signalized crossings, according to local department of transportation practices. Do not split vehicle and pedestrian access points in a way that increases the difficulty of meeting a signal warrant for the pedestrian crossings.
- Good sightlines are required at intersections that are unrestricted by grade change, blind curves, and vegetation, and adequate queuing distance for vehicles turning from one roadway to another.
- Where possible, locate access points on the right side of the roadway for inbound traffic to eliminate crossing movements. Maximizing accessibility for inbound trips may attract users more effectively than improvements aimed at exiting traffic.
- Non-signalized intersections should be located so that signal control can be installed at a later time if necessary.
- An exclusive right-turn lane should be provided only when the lack of one would result in unacceptable traffic operations. An additional turn lane may lengthen pedestrian crossings. If used, the lane should be a tapered section with sufficient width to accommodate the required traffic, which may include buses.
- Left-turn storage pockets are recommended when provable that they noticeably improve traffic conditions and reduce conflicts with through traffic flows.
- Locating exits directly across from highway off-ramps should be avoided to discourage wrong-way entry onto freeways.

### 6.2.3 Access Roads

- Station access roads are intended for low speed travel and should be designed accordingly.
- Unless otherwise approved by WMATA, access roads should generally not tie into low-volume residential streets, but should instead join collector or arterial street systems to keep Metro traffic out of surrounding neighborhoods.
- Roadway lane count is based on anticipated traffic volume. The number of lanes assigned to ingress, egress, and turns are determined by traffic analysis developed or approved by WMATA. Construction, maintenance, police, and emergency vehicle access should be considered when planning roadways.

- Pedestrian crosswalks are to be provided at all legs of access road intersections.
- Consider prohibiting Right Turn on Red movements at access road intersections with regular pedestrian traffic.

#### 6.2.4 High Occupancy Vehicle (HOV) Facilities

- The HOV function is designated at specific stations that have access to major traffic arteries or to limited access highways. It consists of commuter bus and van pool spaces, and may be used to accommodate oversized vehicles such as RVs and campers.
- Storage bays for all-day bus parking must be, at minimum, 12'-0" x 40'-0" in size.
- Re-circulation paths should be provided from storage bays to drop-off areas for afternoon and evening curbside pickups.

#### 6.2.5 Parking Structures

- The design and construction of parking structures must conform to the requirements of either WMATA Design Criteria or the local jurisdiction, whichever are more restrictive.
- Allow for flexibility within parking structures to accommodate existing or anticipated pedestrian routes along clearly defined desire lines.
- Parking structures for transit use should be separated from the station with fire-rated construction and/or by fire separation distance, as required by National Fire Protection Association (NFPA) 130 and applicable

building codes, or with an equivalent protection as accepted by the authority having jurisdiction.

#### 6.2.6 Site Park & Ride Facilities Design

The following points should be included in the design of both surface parking lots and parking structures:

- Park & Ride should function as all-day automobile parking.
- Parking spaces for standard cars and accessible spaces should be included, as required by ADA Accessibility Guidelines.
- Provide exclusive access to parking lots from the arterial street system. Direct vehicular access from secondary streets through residential neighborhoods should be avoided.

#### Consider this...



Consider designing parking facilities to be artful civic architecture and/or multi-use community amenities.

*Example: 1111 Lincoln Road, Miami Beach, FL*

- Access roads should be kept to a minimum, and should provide the clearest, most direct access to the parking lot. Where access roads have combined use with mixed bus and auto traffic, entrance and exit conditions from the parking lot should be carefully studied to minimize turning movements against oncoming traffic.
- Grading design must not impact existing trees, which are to be preserved. Site grading must meet existing grade within the WMATA property line and meet existing grade at all structures.
- Cut-and-fill of roadway or parking lot side slopes must not extend outside the WMATA right-of-way line.
- Refer to the WMATA Design Criteria for right-of-way fencing.

### 6.2.7 Parking Access and Revenue Control

- Park & Ride facilities may function as either a pay-on-exit or pay-on-entry system, with control gates for collecting payment. The preferred payment system is a cashless, pay-on-exit gate at each point of egress and exit. Park & Ride facilities should be designed to provide adequate queuing for both pay-on-exit and pay-on-entry systems. If a pay-on-entry system is to be employed, the control gates should be located so that the car queue is inside the facility itself and does not disrupt flow to any other part of the station or on nearby streets.
- Adequate distance for automobile queuing between the access control gates to a Park & Ride facility and the adjacent intersection should be provided. The storage distance should factor in the number of

automobiles entering and exiting the access point in the peak hour, the level of service of the intersection, and the timing of the traffic signal, if one is present.

### 6.3 Standards

The following standards apply when designing parking structures and Park & Ride facilities:

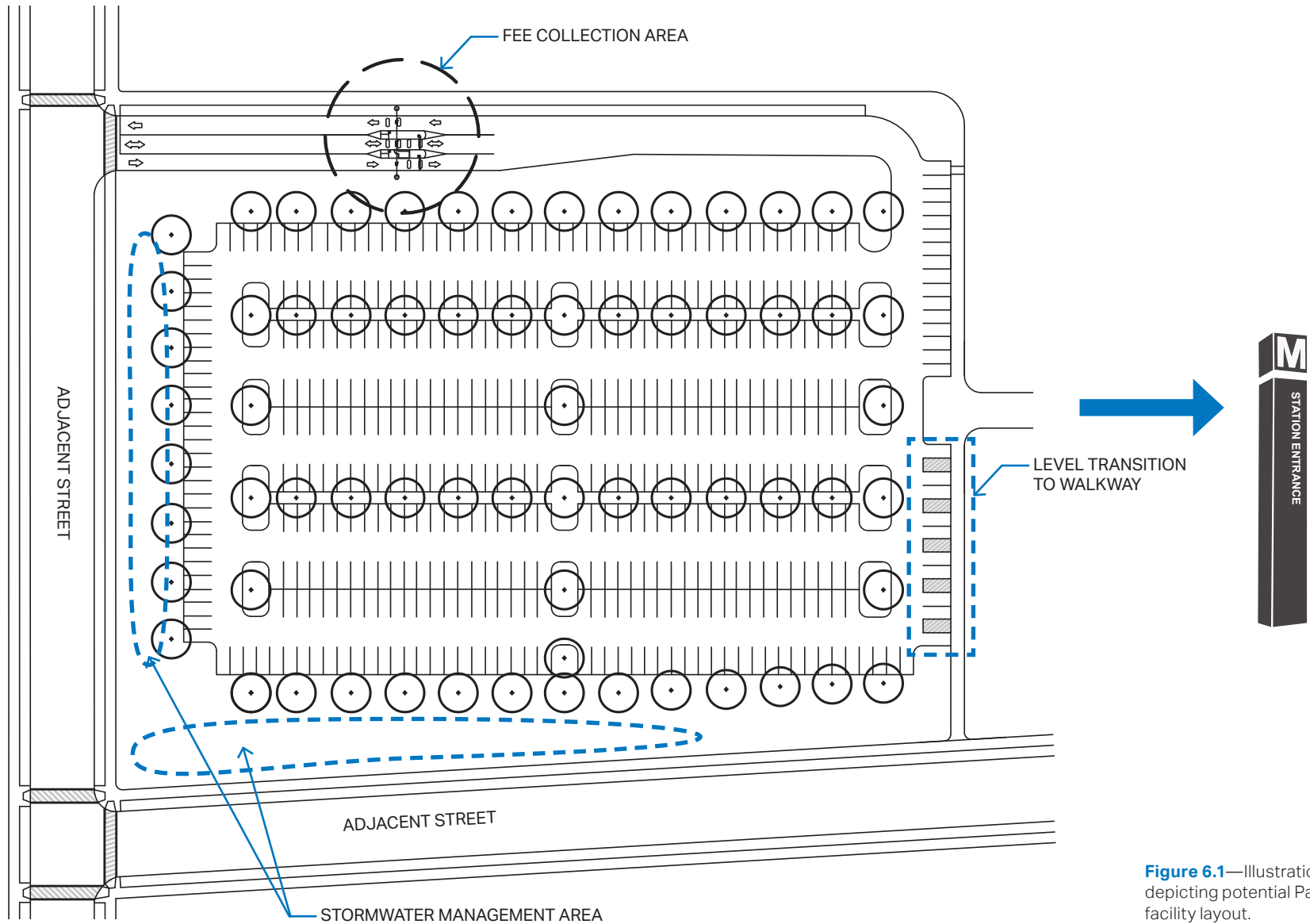
- Slopes on WMATA parking lots and structures must be a maximum of 5 percent. Refer to AASHTO guidelines for minimum and maximum slopes for site drainage on roadways and parking facilities.
- All WMATA road designs should follow AASHTO guidelines.
- For any traffic study, levels of service (LOS) at signalized intersections should be analyzed in accordance with the procedures specified in the most current version of the Highway Capacity Manual, the industry-accepted standard for roadway and intersection capacity analysis.
- The relationship between facilities for different transport modes should be informed by the Urban Street Design Guide produced by NACTO, or by other multi-modal design guides referenced in this guide.
- AASHTO guidelines for horizontal and vertical sightlines on access roads should be used, particularly at intersections. Poles, signage, signposts, etc. must not block access or continuity of pedestrian and bicycle paths.
- The number of parking spaces should be based on projected parking demand at the station, amount of available land, demand at parking facilities at other stations along the rail line, quality of vehicular access from the regional roadway system, and the capacity of the surrounding street system.
- The number of accessible parking spaces must meet the minimum requirements of ADA Standards for Accessible Design and any local ordinances. If past trends show that demand for accessible parking exceeds the number of available spaces at an existing station, WMATA may require additional accessible spaces be provided as part of any new parking facility at that station.
- In general, large parking areas should be subdivided into sections to reduce the scale. Parking lots should be divided into parking areas of not more than 500 spaces, each separated by a landscape buffer. Refer to Chapter 8 for landscaping requirements.
- For improved safety, parking aisles should be oriented toward the station entrance in the direction of pedestrian flow. Aisle lengths should not exceed 400'-0".
- The standard parking layout is 90-degree parking with aisles designed for two-way traffic.

- Park & Ride lots should assume a posted design speed of 5 mph.
- The Parking Access and Revenue Control array should have a three-lane reversible configuration at all parking facilities to accommodate the high directional split differences between the morning and evening peak travel periods. Two-lane exits help ensure that the exit remains in service even when construction, maintenance, or a stalled vehicle temporarily blocks one lane.
- The maximum grade approaching a sign-controlled or signalized intersection is two percent for the access road profile and three percent for the intersecting road. Maintain a one percent minimum cross-slope for drainage, away from pedestrian walkways and curb cuts.
- Access roads should be designed in accordance with AASHTO design for secondary roads, or for arterial roads where traffic volumes require a wider section.
- Automobile access roads should be designed in accordance with AASHTO design standards and local jurisdictional requirements.
- Minimize the number of access points. Access points should be spaced at least 150'-0" apart. A distance of 350'-0" is considered desirable.
- A sufficient number of entrances should be provided to allow traffic to operate at LOS D or better at adjacent intersections.
- New street profiles at intersections and mid-block crossings should be designed to maintain a crosswalk cross-slope (or profile grade on the street) of two percent or less. In addition, crown slopes on streets should be kept as low as possible, but no more than two percent, to provide access for persons with disabilities.
- Whenever an entrance must be located near a "T" intersection, it should be placed directly at the intersection. Offset intersections are not acceptable. If an offset distance is unavoidable and provision for left turn movement is not required, the distance between the street centerlines should be a minimum of 150'-0".

**Table 6.1**—Standard dimensions for parking and circulation

Facility	Standard
Automobile Turning Radii	<ul style="list-style-type: none"> <li>▪ 23'-0" outside curb radius on access roads, 15'-0" curb radius in parking facilities</li> </ul>
Motorcycle Parking Spaces	<ul style="list-style-type: none"> <li>▪ 4'-0" X 8'-0" (located adjacent to Kiss &amp; Ride)</li> </ul>
Park & Ride Spaces	<ul style="list-style-type: none"> <li>▪ 8'-6" x 18'-0"; 24'-0" aisle between rows or jurisdictional requirements, whichever is more stringent</li> </ul>
Access Roads – Vertical Clearance	<ul style="list-style-type: none"> <li>▪ Clearance over a roadway must conform to or exceed the minimum vertical clearance requirements of the jurisdiction in which the road is located: DC: 14'-6"; MD: 16'-9"; VA: 16'-6"</li> </ul>
Access Road Lane Width (Single Lane Road)	<ul style="list-style-type: none"> <li>▪ 13'-0" excluding gutter pan, for roads with automobile traffic only; 15'-0" excluding gutters for roads with buses and automobiles*</li> <li>▪ Buses and automobiles: 15'-0" minimum outer lane excluding gutter</li> </ul>
Access Road Lane Width (2 or More Lanes)	<ul style="list-style-type: none"> <li>▪ 11'-0" per lane excluding gutter pan for automobile only lanes*; 15'-0" per lane where buses operate excluding gutter</li> </ul>
Parking Access Road Turning Radius:	<ul style="list-style-type: none"> <li>▪ Minimum outside turning radius R=24'-0"</li> </ul>
Access Road Roundabout Dimensions	<ul style="list-style-type: none"> <li>▪ Single-lane minimum 120'-0" inscribed circle diameter; multi-lane minimum 185'-0" inscribed circle diameter</li> </ul>
High Occupancy Vehicles (HOV)	<ul style="list-style-type: none"> <li>▪ 15'-0" X 45'-0" (45 degree angle for commuter buses)</li> </ul>

\*Additional lane widening is required in curved sections per AASHTO design standards; add 1 foot on each side of roadway for curb and gutter section.



**Figure 6.1**—Illustration depicting potential Park & Ride facility layout.





## Chapter 7—Joint Development

By working in partnership with local communities, transit-oriented development (TOD) can be a catalyst for economic development and smart growth where people live and work within a short walk to a transit station. This guide is intended to guide planning of TOD on WMATA properties, referred to as joint development, to ensure that the relationship between development requirements and transit requirements result in the safest, most convenient access for transit riders and high-quality neighborhoods and places.

WMATA's main purpose is moving people and serving transit customers. WMATA's joint development partners should expect to regularly coordinate their master plan with WMATA and local jurisdictions on matters concerning transit operation needs and safety.

### Transit-Oriented Development

TOD is commonly defined as moderate- to higher-density development that is within an easy walk of a transit station/stop, generally within a 5 to 10 minute walk (approximately a ¼- to ½-mile distance from the transit station). A TOD project generally includes a mix of uses at a walkable scale, including housing, employment, and retail opportunities. WMATA encourages a mix of uses at stations as a means to increase station area activity, improve customer safety and support local businesses. TOD also includes the careful design and orientation of sidewalks, streets, bikeways, bus facilities, and open space within the immediate station area and is concerned with their connections to and into surrounding neighborhoods.

WMATA supports joint development that promotes the use of public transportation. The joint development partner must seek to deliver the maximum benefits of transit access to future residents and employees. Through collaboration with WMATA, the joint development partner must fully integrate transit access requirements, standards, and guidelines into the TOD master plan. If a plan conflicts with WMATA Standards and Guidelines, it must be resolved with WMATA prior to the developer submitting its plans for jurisdictional review. As transit stations may include facilities for buses, shuttles, taxis, etc., the uses can create a highly congested station area. The ability to successfully integrate and interconnect development uses with transit uses, and vice versa, makes the difference between a successful and a less-than-successful TOD.

### 7.1 Principles

To this end, the stated goals of WMATA's Joint Development Program are to:

- Attract new riders to the transit system by encouraging commercial and residential development projects in proximity to Metrorail stations. Assist WMATA local jurisdictions in their economic development goals.
- Create activated, walkable, safe developments that include public realm amenities that directly and intuitively link people with nearby transit services.
- Create transit-oriented development that can be built in phases over time.
- Create sustainable communities that achieve LEED Neighborhood Development certification or other third party performance metrics.

## 7.2 Practices

The practices below should be followed to achieve the above principles:

- Encourage attractive public open spaces near or adjacent to the transit station entrance to emphasize the station as a public space and provide comfortable waiting and drop-off areas.
- Make the transit facility a focal point of activity within the larger TOD area. This will encourage “trip linking,” which is the ability to visit several destinations during one journey.
- To help enhance the station as an activity center, consider locating public facilities such as libraries, post offices, police sub-stations, government or municipal buildings, daycare centers, or educational facilities adjacent to the station. Additionally, some of these facilities could also attract additional transit riders, thus reducing automobile traffic on local streets.

The following practices should guide the planning and design of joint development buildings, neighborhoods, and public places:

- Focus street-facing windows and “active” uses in TODs like storefronts along primary pedestrian routes. Sidewalks bounded by stores and shops should allow WMATA customers to “multi-task” their transit trip by providing opportunities to fulfill errand and shopping needs while walking to or from the transit station.



**Figure 7.1**—Photograph depicting an activated multi-modal street in transit-oriented development.

- Locate walkways in a manner providing unimpeded access to commercial buildings, residences, and commercial or retail uses from transit stations or streets with a transit stop.
- Give preference to ground-level pedestrian routes to support retail uses and encourage activity in the TOD.
- Embrace multi-modal “complete streets” to provide walkable circulation throughout the TOD and station area.
- Provide convenient crosswalks and traffic signals phased to accommodate pedestrian street crossing.
- Avoid crossing main pedestrian circulation and bus routes with driveways serving private-parking garages within the TOD.
- Design pedestrian routes universally accessible by wheelchairs, strollers, scooters, and other mobility aids with flat rollable surfaces per the ADA Standards for Transportation Facilities.
- Encourage amenities at the sidewalk level that will serve and attract pedestrians moving to or from the transit station, such as landscaping, weather protection, public art, street furniture, street lighting, public phones, and convenience retail options like drugstores, markets, coffee shops, newsstands, and dry cleaners. Such activities should be located as close as possible to the transit station without interfering with transit access in the immediate station area.





**Figure 7.2**—Photograph showing example of transit integrated with a central public space within a transit-oriented development.

### 7.2.1 Street Pattern

The following practices should guide plans for improving street patterns in TODs:

- Create small, walkable development blocks that facilitate access both within the transit facility and throughout the TOD, increase the efficiency of transit circulation, and offer more choices for pedestrians.
- Establish a street hierarchy for the design of streets and circulation patterns to suit their specific access functions throughout the TOD area.
- Loading areas for joint development should not conflict with transit circulation. Separate, intuitive, and convenient loading/service circulation must be provided.
- Design “traffic calming” measures for streets and intersections to accommodate and give first preference to pedestrians and bicycles, and second preference to vehicles. Traffic-calming street design for non-transit routes may include narrow streets, bulb-outs, and on-street parking, among other design elements, and can help to slow traffic, reduce crossing distances, provide space for landscaping and bike access, and ultimately create an enjoyable and safe pedestrian experience. Traffic-calming measures should not impede transit vehicle access and operations within the TOD.
- Design the street plan and street cross-sections to reflect the street hierarchy incorporating “traffic-calming” measures for streets and intersections as

appropriate. For example, the street network should be designed with narrow secondary and local streets that contain on-street parking. Transit vehicles should be accommodated on arterial, collector, and primary streets. On-street parking should be located to minimize conflict with operation of transit vehicles.

- Create multiple direct, clearly marked, and safe vehicle and pedestrian connections or links between the station area and the surrounding neighborhood to produce seamless, continuous pedestrian and vehicular access to transit from surrounding areas.

### Consider this...



Consider the potential conflicts between loading activities and transit circulation within joint development. Separate intuitive and convenient loading/service circulation must be provided.

*Precedent: Numerous conflicts between bus circulation and loading activities occur at Rhode Island Ave - Brentwood Metro Station (Washington, DC)*



**Figure 7.3**—Photograph showing an integrated street grid within joint development.

- Encourage use of tree-lined streets, decorative street lighting, banners, and public art to distinguish primary access streets from secondary streets.
- Avoid the creation of physical pedestrian barriers such as berms, walls, or fences between the surrounding neighborhood and transit stops.
- Use simple street grid systems with multiple cross connections and access options to the transit facility. In general, avoid dead-end streets and cul-de-sacs.
- Locate loading and drop-off zones to avoid conflicts with vehicular and pedestrian circulation. No loading or service operations may use bus circulation routes or primary vehicular access routes.

### 7.2.2 Buses, Taxis, and Bicycle Facilities Throughout the Joint Development Area

- Large, high-density areas of joint development on a station site may require bus, taxi, and bicycle facilities to be located outside the immediate transit facility.
- Facilities for bicycle storage should be coordinated with the local jurisdiction's bicycle coordinator and with WMATA staff.
- Bicycle access to the station and the development site should be encouraged, and connections to bicycle paths or other facilities in the surrounding community should also be provided. The design should incorporate bicycle lanes, sharrows, crosswalks, and curb cuts to facilitate bicycle circulation.





**Figure 7.4**—Photograph depicting integrated cycle track with access to Metrorail Station.

### 7.2.3 Parking

The type, size, and location of parking facilities can significantly impact the quality of a TOD area. The type and size of parking facilities provided are based on WMATA's comprehensive understanding of the station type, ridership, surrounding development, and the accessibility of the station. Any proposals to change the type and the size of a parking facility must obtain approval from WMATA.

Where and how parking facilities are located, and how they are designed, can greatly influence traffic patterns and congestion, pedestrian access to the station facility, and ultimately the economic and social success of the TOD. The following practices should guide the design of parking facilities:

- Parking facilities should be designed and located to allow parking to be integrated into the TOD in an unobtrusive manner.
- The location of the WMATA parking facility is subject to the criteria for an accessible path to the station entrance and for maximum walking distances, as discussed in previous chapters.
- WMATA's transit parking should be located to make it convenient for customers to park their automobiles and ride transit.
- Placemaking, and creating pleasant pedestrian experiences on the way to the transit station, must not be compromised while considering the location of transit parking.
- Surface parking lots for private development should be located off of main activity streets, behind buildings, or in the interior of a block to alleviate their negative visual impact and prevent pedestrians from needing to walk through them to access a building's main entry.
- The use of alleys or driveways off side streets should be encouraged for parking lots located at the rear of buildings so they are located away from the main pedestrian paths to the station entrance.
- Parking facility sharing means that joint development and WMATA parking share the parking garage footprint.
- Separate parking access, exit, and garage infrastructure should be provided for private and WMATA operation and management.
- The size and location of parking facilities throughout the TOD should enhance shared-use strategies that are convenient to both commuters and local businesses.
- Offering long-term parking that serves commuters and local customers can increase both transit ridership and store revenues by combining potential markets.
- WMATA-owned parking facilities shared with development uses must be compatible with WMATA's parking program policy.

### 7.2.4 Structured Parking

- Parking structures that will be operated and maintained by WMATA must be designed in accordance with the criteria included in the WMATA Manual of Design Criteria, Facilities.
- Where demand warrants, well-designed structured parking integrated with the station area and dispersed throughout the TOD should be provided to support local businesses and residential uses. Parking structures should be designed so as to not overwhelm the station area or the TOD.
- Separate access to each parking area should be provided, which may reduce peak rush-hour congestion. Visual distinctions should be made between daily parking and short-term parking areas.
- There should be direct pedestrian access to parking structures in commercial, retail, and residential buildings adjacent to the transit facility. Short- and long-term parking within such buildings should be incorporated where possible.
- Driveways to off-street parking areas should be located on secondary streets and alleyways to avoid conflict with transit vehicles that operate on primary streets.
- Parking facilities should release pedestrians onto primary pedestrian routes and should be located to promote retail opportunity along these routes, especially between the station entrance and parking structures.



**Figure 7.5**—Photograph showing integrated parking garage in joint development.

- Consider “wrapping” parking structures with retail or other non-parking active uses along their main and secondary street façades. Wrapped parking structures improve the casual monitoring and appearance of the main pedestrian routes and encourage development on street-side edges of parking structures.
- WMATA parking structures that are wrapped with development must also conform to the requirements for an open parking structure per the WMATA Manual of Design Criteria, Facilities.
- When wrapping a garage with other uses, avoid requiring loading access within the garage. If practicable, loading and service access should be provided through other means.
- For the security of transit customers, every elevator hoistway and stair tower in a WMATA parking structure should have glazed walls that users on streets, alleys, and station platforms can see through.
- At stations where WMATA has plans to expand parking structures to meet future demand, land adjacent to the structure should be provided for horizontal expansion. WMATA parking structures cannot operate during periods of construction for vertical expansion.

### 7.2.5 On-Street Parking

- On-street parking provides direct access to sidewalk retail uses and helps to buffer pedestrian activity from vehicular traffic. Parking meters should be used to discourage all-day parking along streets intended for short-term parking.
- On-street parking and driveways at key points near the transit station that might hinder the efficient movement of pedestrians, transit, or other vehicles accessing any station facility should be limited.
- On-street parking should be used as a way to reduce vehicular speeds where appropriate.



**Figure 7.6**—Example of a calm street within transit-oriented development that supports cars, pedestrians, bicyclists, and includes sustainable infrastructure.

### 7.3 Standards

- For security purposes, any portion of a parking structure located within 50'-0" of a Metrorail station or the rail right-of-way should incorporate physical barriers in the design at all fenestrations and along the parapet of the highest parking levels. A wire mesh partition can prevent debris from being thrown from the parking structure onto rail tracks while still maintaining open-air requirements.
- The amount of private development parking provided should support the TOD that meets the local jurisdiction's minimum zoning requirements for parking spaces. Providing additional parking spaces beyond the minimum requirements may discourage transit use if automobile use is perceived as a more attractive travel option
- Not less than five percent of the total parking areas of any lot should be devoted to internal landscaping and interior parking separation areas. This requirement can be satisfied by using 10-foot-wide landscaped areas, located every second parking aisle and bordered on each side by concrete mowing strips. Use landscaped strips to make grade adjustments at the site.

#### 7.3.1 Phasing of Joint Development Plans

Joint development plans need to be phased in over time without interrupting transit operations. Phasing plans must be coordinated with Metro to ensure appropriate access, wayfinding measures and interim facilities (see chapter 10).



Existing conditions + site analysis used to inform phasing.



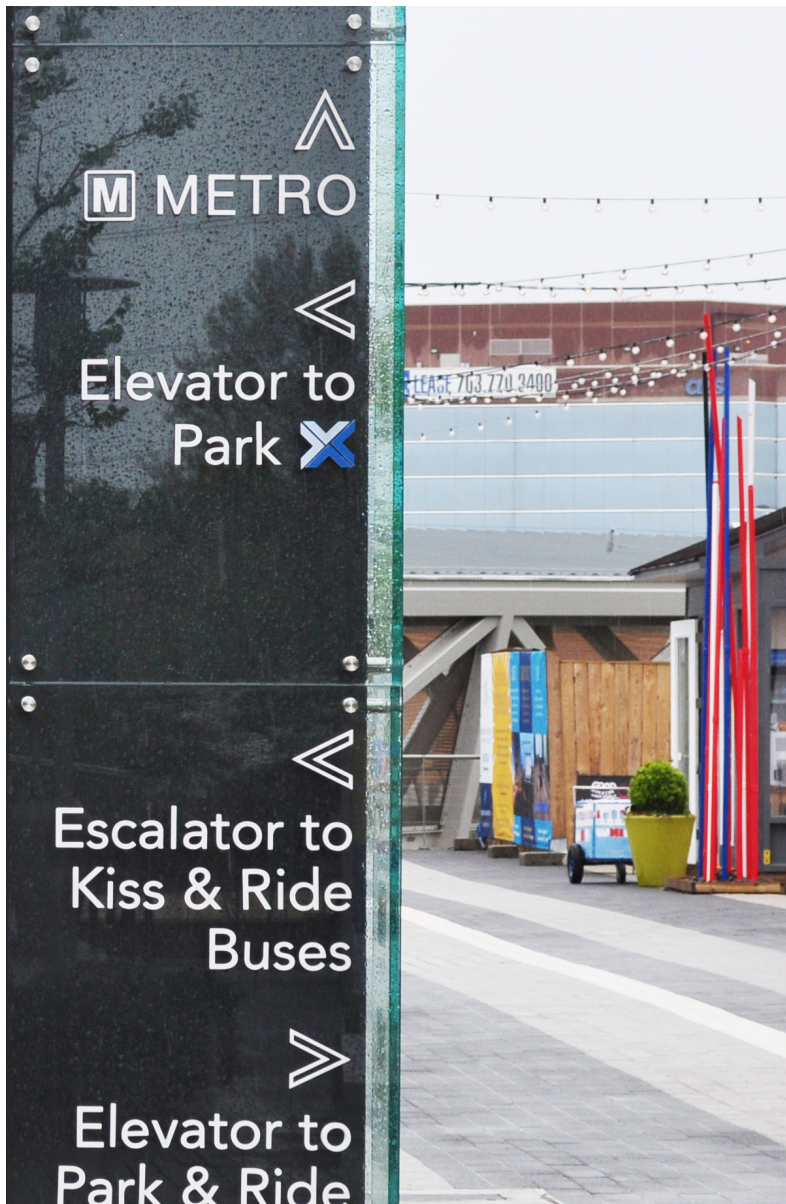
*Plan for joint development phase one that respects transit access.*



*Plan for joint development final phase that fully integrates transit access and the new TOD.*

**Figure 7.7**—Example illustrations depicting stages of joint development planning considering phased development and continuity of access for all modes.





## Chapter 8—Wayfinding and Landscape Design

Station area landscape design must serve a number of important purposes simultaneously. Landscape features contribute greatly to a welcoming, comfortable environment, they guide riders to their desired destinations, they promote environmental quality and sustainability, and they can significantly enhance public safety. Landscape features, materials and systems within the station area must meet Metro criteria and local jurisdictional requirements.

### 8.1 Principles

The following principles should guide the design of station areas:

- Improve the visual character and environmental conditions at station sites.
- Ensure station sites are both attractive and functional.
- Provide a sense of order and orientation to station entrances throughout the station area.
- Provide a station environment that is conducive to safe customer experiences.
- Utilize and apply principles of Crime Prevention Through Environmental Design.
- Utilize Low Impact Development techniques as a land planning and engineering design approach that emphasizes conservation and use of on-site natural features to manage stormwater runoff and protect water quality.

## 8.2 Practices

### 8.2.1 Wayfinding

The following wayfinding guidelines are provided to improve access to Metrorail stations:

- Transit users should be able to quickly orient themselves to the station area as they exit a station or deboard a bus.
- Clear and highly visible wayfinding signage should be provided throughout all transit areas, directing customers to and from station entrances, to all transit site facilities, to nearby points of interests outside transit zones, and to local roadways.
- Directional signage should be clearly visible wherever customers need to choose their direction of walking, bicycling, or driving on WMATA property. All signage on metro property should follow WMATA wayfinding standards.
- Signage for bus routes, timetables, and maps of the station area and vicinity should be clearly posted. Signage leading to WMATA property should follow wayfinding standards of the jurisdiction.
- Routes should be clearly and consistently identified.
- A convenient and legible sign system should be implemented to direct pedestrians to and from transit facilities and throughout the station area.

**Figure 8.1**—Photograph showing example of integrated wayfinding.



- Innovative graphic design techniques, such as painted arrows on floors and color in architectural finishes, should be used as part of wayfinding strategies.
- Wayfinding signs should be provided on streets within several blocks of the station, particularly if the station is not very visible from these areas.
- Wayfinding information should be consistent system-wide, with neighborhood maps for each station area that show transit stops and bus routes servicing the area, as well as the surrounding bicycle network.
- Signs guiding vehicles, pedestrians, and bicycles along principal municipal streets should be posted to direct traffic safely and efficiently to the station site.
- Signs should be placed along bicycle routes to direct bicyclists safely and efficiently along designated routes and to bicycle parking facilities, if available.
- For the best visibility, no berms or plant-material barriers should obstruct views within the lots, drive aisles, or at roadway exits.
- Species of trees that obscure visibility at eye level should be avoided.
- Transit facilities should have open designs to allow the greatest visibility of passenger waiting areas and paths.
- Retaining walls and guardrails should be designed along with landscaping in an aesthetically pleasing manner and to minimize visual impacts on existing structural and natural features.
- Landscape features, including plant material should be coordinated with security camera placement and view lines.

### 8.2.2 Landscape Aesthetics and Visibility

The following practices are recommended to improve the visual character and pedestrian experiences at station sites:

- Ensure that plantings do not obscure or negatively impact wayfinding systems, personal safety, or security.
- Trees and other landscaping elements should not interfere with drivers' sightlines, especially between the station entrance and the Kiss & Ride lot, or at street intersections.



### 8.2.3 Landscape Amenities

The following practices are recommended to improve the visual character and environmental conditions at station sites:

- Use of landscaping stones or crushed rock in planters is prohibited adjacent to station entrances, bus facilities, or Kiss & Ride facilities where glazed structures are located.
- Street furniture such as benches, trash receptacles, newspaper stands, and wayfinding signage should be provided along pedestrian paths, but not within the clear route of travel.
- Barriers or buffers should be provided between pedestrian paths and motor vehicle traffic to improve safety and enhance the pedestrian environment. Examples of barriers include landscaped buffers and on-street parking.
- Encourage active uses adjacent to parking areas to reduce the perceived isolation of parking lots. Retailers or restaurants in the station area generate activity, thereby increasing natural surveillance of the property. The owners and employees of these businesses would also have a vested interest in the security of the parking.

**Figure 8.2**—Photograph depicting how green infrastructure can be integrated into an animated streetscape within Transit-Oriented Development.

### 8.2.4 Planting Strategies

The following practices are recommended for the maintenance and placement of trees and vegetation at station sites:

- Utilize Low Impact Development stormwater management principles.
- New or replacement trees should be installed using a planting ratio with a low-maintenance program that ensures plant establishment, long-term success, and other benefits to customers such as visual pleasure, design, and shade.
- Re-vegetate all fill slopes with trees and shrubs where appropriate.
- Tree preservation should be maximized, and new trees should be planted away from light fixtures in order to avoid shadows or blocking of light.
- Trees should be planted so that the mature drip line of the tree canopy does not extend into the travel paths of buses.
- Trees should be planted along pedestrian paths to provide shade and a pleasant walking environment.
- Planted areas should be designed in ways that discourage pedestrians from using them as pathways.
- Trees should be planted in pedestrian waiting areas to provide shade and a pleasant waiting environment.



**Figure 8.3**—Photograph showing an inviting station area with direct, intuitive routes to the station.

### 8.2.5 Security of Customers

The following guidelines are provided for station site planning to enhance the security and safety of transit customers:

- For personal safety and security reasons, avoid creating potential hiding spaces with landscape materials.
  - Reinforced vehicle barriers should be incorporated into the station site plan where necessary to control the risk of unauthorized vehicles accessing sensitive transit areas and pedestrian walkways.
  - When transit site facilities are being planned in conjunction with mixed-use facilities, such as in joint development master plans, comprehensive strategies that integrate traditional access management techniques and security-oriented site design into the TOD environment should be developed early in the planning process. For instance, instead of allowing large vehicles accessing an adjacent private facility to enter via the transit facility, incorporate a large-vehicle entrance farther away.
  - Materials that can be easily cleaned of graffiti should be used for all architectural systems at the station site.
  - Bike lockers should be located within sight of the station entrance, but not under track girders or near station entrance structures due to security concerns.
  - Illumination levels should accomplish the purpose of differentiating decision and transition posts, task areas, signage, and areas of potential hazard.
- Not only is the quantity and intensity of light important, but its distribution is important as well. Illumination should be designed for uniform distribution, consistent with the design objective.
  - The characteristics, location, and selection of luminaries should fulfill their primary purpose while also minimizing glare or interference with task performance and vehicular traffic.
  - Illumination should be designed so that there is no light spillover onto adjacent land and properties.



**Figure 8.4**—Example of ambient illumination in public space.



*Example of open plazas that provides visibility at the ground plane level.*



*Example of landscape features that guide flow of pedestrian activity.*



*Example of flexible outdoor space that allows for temporary events & programming.*



*Example of artistic animation of open space.*



*Example of amenities that help activate public space.*



*Example of outdoor spaces that provide shaded seating.*

### 8.3 Standards

The following standards apply when implementing the previous practices:

- Light levels should be designed for an expected bulb life of two years.
- Stormwater management systems should conform to local jurisdictional requirements.
- Height of landscape plantings should be no greater than 3'-0" high, except trees.
- Pedestrian barrier fences should be 3'-6" in height.
- Rail right-of-way security fences should be in accordance with the standards described in the WMATA Manual of Design Criteria.
- Site lighting photometric standards should be in accordance with the standards described in the WMATA Manual of Design Criteria.
- The lowest branch of any tree should be a minimum 8'-0" above pedestrian paths.
- Pedestrian barriers may consist of densely planted hedges, ornamental fencing, seat walls, or other low maintenance landscape treatment.
- A minimum 6-inch-tall curb or other barrier should be provided around landscape areas or planter boxes adjacent to high-volume walking surfaces. The curb may be designed to allow runoff flow into bio-retention areas.
- Refer to local jurisdictional requirements for the quantity and type of landscape materials to be used in planning private development parking facilities.

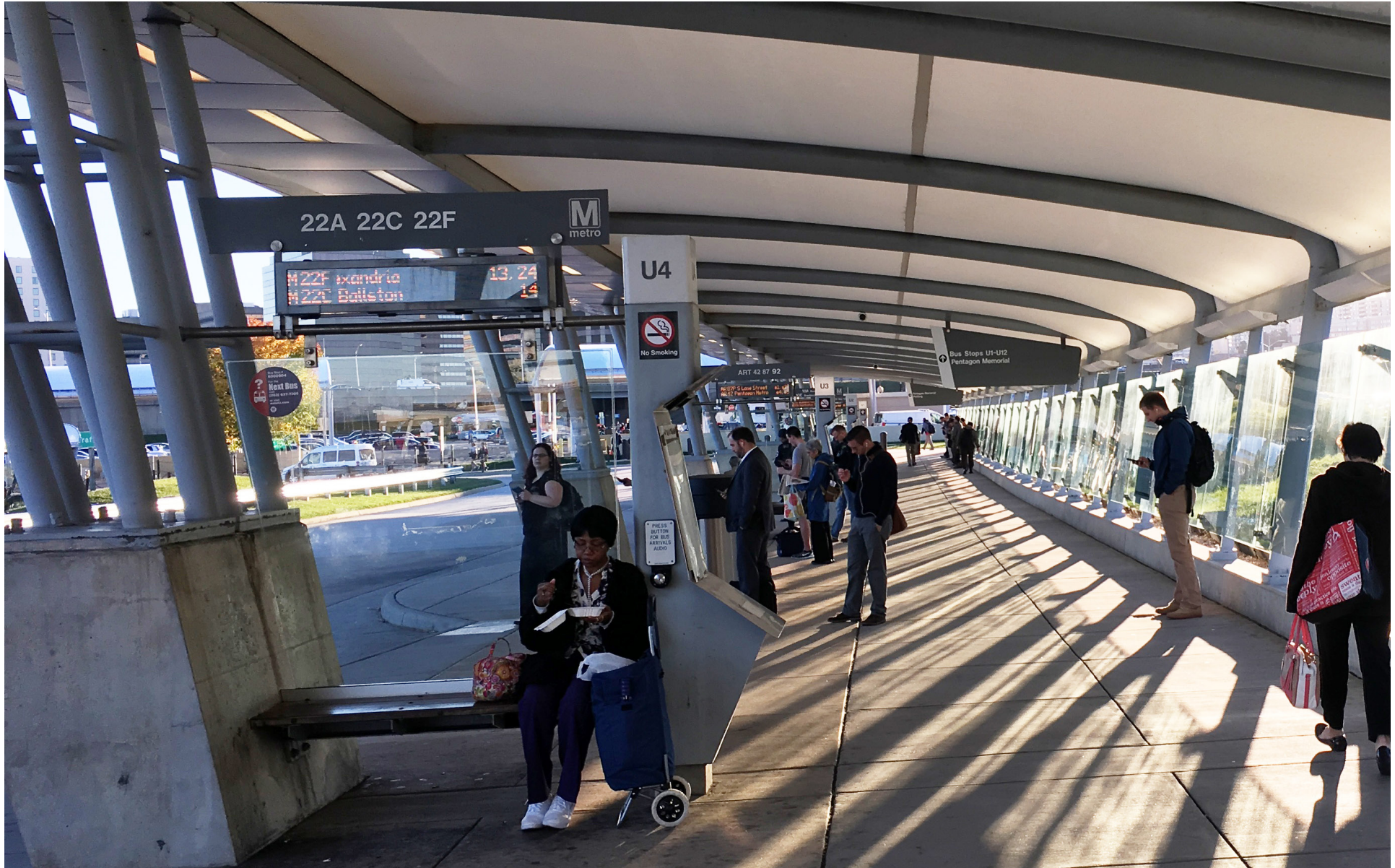
- Exterior walls for elevator and stair towers in any transit facility should be glazed and be located to permit natural surveillance from exterior public areas, streets, and alleys.
- Corners and edges of retaining walls should be rounded to avoid creating potential hiding spaces.

The following standards for illumination levels are applicable for underground, elevated, and exterior space lighting:

- Ensure that all areas of the site accessed by passengers are well-lit and visible from other areas of the site. Adequate lighting is also necessary to deter vandalism. The designer should refer to the Section 4 of the WMATA Manual of Design Criteria, Facilities for planning lighting.
  - Unless otherwise specified in the WMATA Manual of Design Criteria, the following standards can guide the design of lighting systems.
  - The minimum recommended color rendering index of lamps is 65.
  - In areas surveilled by closed-circuit television (CCTV), lamps should be located according to the visual field of the cameras, and have a Color Rendering Index and a light-to-dark ratio of 4:1 at design or 6:1 over time.
  - A maximum uniformity ratio of 3:1 is recommended unless otherwise indicated.
- Illumination levels should follow the recommendations of the Illuminating Engineering Society of North America, unless otherwise indicated by the Metro design criteria.
  - Unless otherwise specified by a local authority, refer to the District Department of Transportation Green Infrastructure Standards, 2014, for construction details and planting materials for green infrastructure systems such as bio-retention or rain gardens: [ddot.dc.gov/sites/default/files/dc/sites/ddot/publication/attachments/2014-Final%20DDOT%20Green%20Infrastructure%20Standards.pdf](https://ddot.dc.gov/sites/default/files/dc/sites/ddot/publication/attachments/2014-Final%20DDOT%20Green%20Infrastructure%20Standards.pdf).



**Figure 8.5**—Maintain clear sightlines through station area landscapes.





## Chapter 9—Maintenance Considerations

The reliability, comfort, and safety of the Metro system depends on the effective maintenance of its facilities. Station area maintenance directly improves access to regional critical infrastructure and the system's most utilized access points. As such, planning for effective and efficient maintenance of station areas benefits all transit riders.

### 9.1 Principles

The following maintenance considerations should guide design, redesign, and/or construction activities in the station area:

- Identify and evaluate the total cost of investment, balancing capital costs for site improvements with their associated operational costs.
- Design site work to minimize the financial, water, energy, and manpower resources needed to maintain the station area.
- Protect access to critical infrastructure.
- Provide staging areas for Metro maintenance staff.
- Identify ample storage areas for station area maintenance equipment.
- Design station areas for optimal operation in all seasons and weather events.
- In joint development, appropriately assign long-term maintenance responsibilities across WMATA, the joint development partner, and the local jurisdiction.

## 9.2 Practices

The practices below should be followed to achieve the above principles:

- Snow storage and loading areas should be planned as part of parking areas and circulation routes.
- Secure storage of snow-removal equipment should be provided within the station area.
- The use of resource-intensive lawns should be minimized. Hardy groundcovers, grasses, shrubs, and trees are preferred.
- Plantings with high salt tolerance should be used in bio-retention and planting areas where blown or shoveled snow will accumulate.
- Vehicular access should be provided in areas where critical infrastructure may need to be delivered or replaced. In these locations, paving must be designed to support vehicular loads.
- Dedicated parking should be provided for Metro maintenance staff.
- The use of permeable pavements should be restricted to non-critical pedestrian paths that will not receive winter salt treatments.
- Bus loop areas may not be utilized for maintenance or service vehicles.

## 9.3 Standards

The following standards apply when implementing the previous practices:

- Construction details and planting materials should be coordinated with Metro Landscaping and relevant Standards from local jurisdictions.
- At least two dedicated parking spaces in each Kiss & Ride facility should be provided for Metro maintenance staff.
- Metro maintenance access corridors should be a minimum of 12'-0" in width.
- Reference WMATA Manual of Design Criteria for allowable materials and specifications.



**Figure 9.1**—Photograph of maintenance activities within station area. Elvert Barnes, FLICKR, <https://creativecommons.org/licenses/by-sa/2.0/>





## Chapter 10—Interim Facilities

During any construction activities on WMATA property or on adjacent land, it is critical to maintain safe, convenient, and comfortable access for users of all modes of transportation. Maintenance of circulation for all modes must be considered during the planning and design process for both Metro facilities and joint development activities. These considerations will affect the phased layout of long-term site improvements, as well as the detailing of temporary interim facilities.

### 10.1 Principles

The following interim facility considerations should guide design, re-design, and construction activities in the station area.

- Apply the access hierarchy and accessibility guidance, described in this guide's introduction, to interim facilities.
- Minimize inconvenience to Metro customers.
- While maintenance of traffic planning for all applicable modes of circulation is needed, pedestrian safety, convenience, and comfort are priority goals.
- Plan Metro and joint development facilities with construction sequencing in mind so that their location, size, and material characteristics are properly coordinated.
- Coordinate construction sequencing in advance to balance the duration of construction with its level of disruption.
- Communicate interim circulation patterns clearly through appropriate wayfinding systems.

## 10.2 Practices

The practices below should be followed during maintenance to achieve the above principles:

- Avoid the reduction or degradation of access points to the station.
- Avoid providing only partial access to Metro facilities, as partial access can increase bus travel miles, impede access during emergencies, and require complicated wayfinding and directional signage.
- Minimize changes to interim circulation patterns.
- When circulation patterns change, interim wayfinding systems must be clearly legible, durable, and accompanied by people to assist and orient Metro customers.
- Proposed lighting for WMATA interim facilities should be provided per WMATA Manual of Design Criteria without spilling over onto adjacent residential communities. Lighting shields must be provided concurrent with lighting installation to mitigate potential lighting spillover.
- Any interim bus facility must be approved by WMATA and the Office of Bus Planning.

## 10.3 Standards

The standards below apply to the previously mentioned practices. Materials are based on level of use, time of use, and duration.

- The dimensions of interim Metro facilities are to match those of permanent improvements.
- The construction materials or operational systems for interim facilities must be coordinated with WMATA based on a case-by-case assessment of the following:
  - Location of facility
  - Level of expected use
  - Duration of possible use
  - Seasonal considerations
  - Accessibility considerations
  - Appearance
  - Revenue implications
- ADA Standards for Transportation Facilities and ADA Standards for Accessible Design and applicable WMATA Manual of Design Criteria, Standards and Specifications, Approved Constructions Plans, and Adjacent Construction Manual should be complied with.
- Lighting levels for interim conditions should not be less than for permanent facilities.

- If WMATA deems necessary, frequent shuttle service to nearby Metrorail stations, every 10 minutes during revenue service, is required during any anticipated closures of Metro street elevators. WMATA's intent for this shuttle is to provide adequate service for WMATA customers and incentives for the developer/contractor in order to maximize construction hours and reduce the duration of elevator closures.
- If WMATA and/or local jurisdictions deem necessary, capacity or access improvements will be made to existing and/or proposed roadways, parking lots, and intersections prior to removing, reconstructing, or relocating Metro facilities.
- If WMATA and/or local jurisdictions deem necessary, crossing times at nearby pedestrian signals will be certified as adequate for senior citizens and people with disabilities and will be adjusted if interim and/or ultimate accessible paths are re-routed via these intersections due to construction at the station site.
- Temporary pedestrian paths must have cane-detectable construction fencing where the bottom 24" of the fence is of a material that will not trap canes.
- Necessary traffic control devices per the FHWA Manual on Uniform Traffic Control Devices and/or jurisdictional standards, including Jersey barriers and static and dynamic signage, should be provided prior to planned closure or detours. A certified Temporary Traffic Control Manager and certified flag persons should be on site.
- Interim facilities, including internal and external signage, should be completed before closure of existing facilities at a time agreed upon with WMATA to allow time for transition, identify an accurate time frame for issuing public notices, and provide for completion of remaining punch list items.
- Necessary local and state permits should be obtained, and variable message signs placed at critical intersections for at least one week to advise customers of impending closure of existing parking and bus facilities and direct them to interim facilities.
- Experienced flag persons should be provided for a minimum of 3 days after the opening of interim facilities and when major new traffic patterns are introduced to help direct customers.
- Proposed lane and sidewalk closures should be certified as consistent with approved public space and building permits.





# Appendices

## A.1 Regulations and Controls

In addition to complying with applicable code and jurisdictional requirements, the planning, design, and construction of Metro facilities should conform to the requirements of the latest Metro Standards and Criteria. This guide is a supplement to the WMATA Manual of Design Criteria. WMATA Standards and Criteria include:

- *WMATA Manual of Design Criteria for Maintaining and Continues Operation of Facilities and Systems* (<https://www.wmata.com/about/business/procurement/solicitations/documents/Volume%206%20Parts%201%20-%20WMATA%20Manual%20of%20Design%20Criteria-3.pdf>)
- *WMATA Standard Specifications, Standard Drawings and Design Directive Drawings* ([https://www.wmata.com/about/business/procurement/solicitations/documents/Volume%204%20-%20WMATA%202014%20CAD%20Standards\\_Approved.pdf](https://www.wmata.com/about/business/procurement/solicitations/documents/Volume%204%20-%20WMATA%202014%20CAD%20Standards_Approved.pdf))
- *WMATA Manual of Graphic Standards*
- *WMATA Tram/LRT Guideline Design Criteria* (<https://www.wmata.com/about/business/procurement/solicitations/documents/Volume%206%20Parts%201%20-%20WMATA%20Manual%20of%20Design%20Criteria-3.pdf>)
- *WMATA ADA Accessibility Checklist Forms in Section 01112: General Requirements of the Specifications*
- *WMATA Adjacent Construction Project Manual* (<https://www.wmata.com/about/business/adjacent-construction/upload/ACPM-Rev-5a-09-21-15.pdf>)

The latest WMATA Standards and Criteria may be obtained from WMATA's Office of Chief Engineer-Facilities and the Office of Chief Engineer-Systems. All design and construction of new facilities, as well as alterations and relocations of existing facilities, should comply with ADA Standards for Transportation Facilities and ADA Standards for Accessible Design.

This guide promotes a safe and accessible pedestrian environment that goes well beyond the minimum requirements of ADA Standards. Many people with disabilities who are unable to operate an automobile or use certain taxi services have adopted transit as their primary mode of transportation. All transit agencies, including WMATA, are required by federal law to provide accessible bus, rail, and alternative paratransit services. Designers should utilize the WMATA ADA Accessibility Checklist Forms when planning station facilities.

### A.1.1 Reference Documents

Many elements of this guide are subject to other regulations, including local jurisdictional design standards, zoning ordinances, and development codes. Other documents to review include:

- *ADA Standards for Transportation Facilities*, US Department of Transportation (USDOT, 2006) (<https://www.access-board.gov/guidelines-and-standards/transportation/facilities/ada-standards-for-transportation-facilities>)
- *Americans with Disabilities Act Standards for Accessible Design*, US Department of Justice Civil Rights Division (US DOJ, 2010) ([https://www.ada.gov/2010ADASTandards\\_index.htm](https://www.ada.gov/2010ADASTandards_index.htm))
- *A Policy on Geometric Design of Highways and Streets*, American Association of State Highway and Transportation Officials (AASHTO, 2001) ([http://nacto.org/docs/usdg/geometric\\_design\\_highways\\_and\\_streets\\_aashto.pdf](http://nacto.org/docs/usdg/geometric_design_highways_and_streets_aashto.pdf))
- *Design and Safety of Pedestrian Facilities*, Institute of Traffic Engineers (ITE, 1998) (<http://library.ite.org/pub/e1d0e494-2354-d714-5188-fbe21cb21457>)
- *Designing Sidewalks and Trails for Access, Part I of II: Review of Existing Guidelines and Practices*, USDOT Federal Highway Administration (FHWA, 1999) ([https://www.fhwa.dot.gov/environment/bicycle\\_pedestrian/publications/sidewalks/sidewalks.pdf](https://www.fhwa.dot.gov/environment/bicycle_pedestrian/publications/sidewalks/sidewalks.pdf))
- *FTA Accessibility Handbook for Transit Facilities*, Federal Transit Administration (2007) (<https://www.transit.dot.gov/regulations-and-guidance/civil-rights-ada/part-37-transportation-services-individuals-disabilities>)
- *Guide for the Design of Park & Ride Facilities*, American Association of State Highway and Transportation Officials (AASHTO, 2004) (<https://bookstore.transportation.org/imageview.aspx?id=319&DB=3>)
- *Guide for the Development of Bicycle Facilities*, American Association of State Highway and Transportation Officials (AASHTO, 2012) ([https://bookstore.transportation.org/collection\\_detail.aspx?ID=116](https://bookstore.transportation.org/collection_detail.aspx?ID=116))
- *Guide for the Planning, Design, and Operation of Pedestrian Facilities*, American Association of State Highway and Transportation Officials (AASHTO, 2004) (<https://bookstore.transportation.org/imageview.aspx?id=549&DB=3>)
- *Guidelines for Providing Access to Public Transportation Stations Report 153*, Transit Cooperative Research Program (TCRP, 2012) ([http://nacto.org/wp-content/uploads/2016/04/1-4\\_Coffell-](http://nacto.org/wp-content/uploads/2016/04/1-4_Coffell-)

- [et-al\\_Guidelines-for-Providing-Access-to-Public-Transportation-Stations\\_TCRP-153\\_2012.pdf](#))
- *Manual on Uniform Traffic Control Devices*, USDOT Federal Highway Administration (FHWA, 2009) (<https://mutcd.fhwa.dot.gov/>)
  - *NFPA 130: Standard for Fixed Guideway Transit and Passenger Rail Systems*, National Fire Protection Association (NFPA, 2014) (<http://www.nfpa.org/codes-and-standards/all-codes-and-standards/list-of-codes-and-standards?mode=code&code=130>)
  - *Proposed Guidelines for Pedestrian Facilities in the Public Right of Way*, Architectural and Transportation Barriers Compliance Board (2011) (<https://www.access-board.gov/guidelines-and-standards/streets-sidewalks/public-rights-of-way/proposed-rights-of-way-guidelines>)
  - *Separated Bike Lane Planning and Design Guide*, USDOT Federal Highway Administration (FHWA, 2015) ([https://www.fhwa.dot.gov/environment/bicycle\\_pedestrian/publications/separated\\_bikelane\\_pdg/page00.cfm](https://www.fhwa.dot.gov/environment/bicycle_pedestrian/publications/separated_bikelane_pdg/page00.cfm))
  - *Transit Capacity and Quality of Service Manual, 3rd Edition*, Transit Cooperative Research Program (TCRP, 2013) ([http://onlinepubs.trb.org/onlinepubs/tcrp/tcrp\\_rpt\\_165ch-01.pdf](http://onlinepubs.trb.org/onlinepubs/tcrp/tcrp_rpt_165ch-01.pdf))
  - *Transit Streets Design Guide*, National Association of City Transportation Officials (NACTO, 2016) (<http://nacto.org/publication/transit-street-design-guide/>)
  - *Urban Bikeway Design Guide*, National Association of City Transportation Officials (NACTO, 2014) (<http://nacto.org/publication/urban-bikeway-design-guide/>)
  - *Urban Street Design Guide*, National Association of City Transportation Officials (NACTO, 2013) (<http://nacto.org/publication/urban-street-design-guide/>)
  - *WMATA Signage Standards Manual* (WMATA, 2009)
- It is the responsibility of the designer to justify any deviation from the established WMATA Standards and Guidelines and to secure the necessary approvals prior to proceeding with final design and construction. Refer to the WMATA Manual of Design Criteria, Facilities for the process.

