



Washington
Metropolitan
Area Transit
Authority

Invitation For Bid

FQ12235/CPR

Direct Fixation Rail Fasteners

August 2012

TABLE OF CONTENTS

NOTICE TO BIDDERS..... 9

NOTICE TO ALL VENDORS 10

SOLICITATION, OFFER AND AWARD 12

SCHEDULE OF PRICES..... 13

ACKNOWLEDGMENT OF AMENDMENTS 15

SOLICITATION INSTRUCTIONS 17

 1. **DEFINITIONS**..... 17

 2. **EXPLANATION TO BIDDER** 17

 3. **PRIOR REPRESENTATIONS**..... 17

 4. **PRE-BID MEETING** 17

 5. **REVISIONS PRIOR TO DATE SET FOR RECEIPT OF BIDS**..... 17

 6. **ACKNOWLEDGMENT OF AMENDMENTS** 18

 7. **PREPARATION OF BIDS**..... 18

 8. **SUBMITTAL OF BIDS**..... 18

 9. **LATE BIDS AND MODIFICATIONS OR WITHDRAWALS**..... 19

 10. **MINIMUM BID ACCEPTANCE PERIOD** 20

 11. **CONTRACT AWARD** 20

 12. **PRE-AWARD INFORMATION** 21

 13. **EQUAL EMPLOYMENT OPPORTUNITY** 22

 14. **OPPORTUNITY FOR DISADVANTAGED BUSINESS ENTERPRISES TO BID**..... 22

 15. **REPRESENTATIONS, CERTIFICATIONS, AND ACKNOWLEDGMENTS**..... 22

 16. **AWARD - SINGLE AWARD FOR ALL ITEMS** 22

 17. **NOTICE OF PROTEST POLICY**..... 22

 18. **REQUIREMENT FOR COST DATA FOR CONTRACT AWARD** 23

 19. **BASIS FOR AWARD** 23

 20. **WMATA'S TAX EXEMPT STATUS** 23

 21. **CONTRACTOR PERFORMANCE EVALUATION** 24

 22. **TYPE OF CONTRACT**..... 24

 23. **ENGLISH LANGUAGE AND UNITED STATES CURRENCY** 24

 24. **BRAND NAME OR EQUAL**..... 24

 25. **FEDERAL/LOCAL/STATE SALES TAX**..... 25

REPRESENTATIONS AND CERTIFICATIONS..... 26

PRE-AWARD EVALUATION DATA..... 34

GENERAL PROVISIONS 37

 1. **DEFINITIONS**..... 37

 2. **ACCOUNTING AND RECORD KEEPING** 37

 3. **ASSIGNMENT**..... 39

 4. **AUDIT AND RETENTION OF RECORDS** 40

 5. **AUTHORITY DELAY OF WORK**..... 41

 6. **CERTIFICATE OF CURRENT COST OR PRICING DATA** 41

 7. **CHANGES** 42

 8. **NONDISCRIMINATION ASSURANCE**..... 42

WASHINGTON METROPOLITAN AREA TRANSIT AUTHORITY

SUPPLY AND SERVICE CONTRACT

IFB FQ12235/CPR

9.	CONTRACT WORK HOURS AND SAFETY STANDARDS ACT-OVERTIME COMPENSATION.....	43
10.	CONVICT LABOR.....	44
11.	CORRECTION OF DEFICIENCIES.....	45
12.	COST OR PRICING DATA.....	47
13.	COVENANT AGAINST CONTINGENT FEES.....	48
14.	DEFAULT.....	48
15.	DISPUTES.....	49
16.	EMPLOYMENT RESTRICTION WARRANTY.....	50
17.	EXTRAS (SUPPLIES).....	50
18.	FEDERAL, STATE, AND LOCAL TAXES.....	51
19.	GRATUITIES.....	52
20.	INSPECTION OF SERVICES.....	53
21.	INSPECTION OF SUPPLIES.....	54
22.	LIMITATION ON WITHHOLDING PAYMENTS.....	56
23.	NEW MATERIAL (SUPPLIES).....	56
24.	NOTICE AND ASSISTANCE REGARDING PATENT AND COPYRIGHT INFRINGEMENT (SUPPLIES).....	57
25.	NOTICE TO THE AUTHORITY OF LABOR DISPUTES.....	57
26.	OFFICIALS NOT TO BENEFIT.....	57
27.	ORDER OF PRECEDENCE.....	57
28.	ORGANIZATIONAL CONFLICT OF INTEREST.....	58
29.	PATENT INDEMNITY.....	59
30.	PAYMENTS.....	59
31.	PAYMENT DEDUCTIONS - NONCOMPLIANCE WITH DBE REQUIREMENTS.....	59
32.	PRICE REDUCTION FOR DEFECTIVE COST OR PRICING DATA - MODIFICATIONS	
	60	
33.	PRICING OF ADJUSTMENTS.....	61
34.	RESPONSIBILITY FOR INSPECTION.....	61
35.	RETENTION OF DOCUMENTS.....	61
36.	RIGHTS IN TECHNICAL DATA.....	61
37.	ROYALTY INFORMATION.....	63
38.	SEAT BELT USE POLICY.....	63
39.	SENSITIVE SECURITY INFORMATION.....	64
40.	STOP WORK ORDER.....	64
41.	SUBCONTRACTOR COST AND PRICING DATA-PRICE ADJUSTMENTS.....	65
42.	SUBCONTRACTOR PAYMENTS.....	65
43.	TERMINATION FOR CONVENIENCE OF THE AUTHORITY.....	66
44.	TITLE.....	70
45.	VARIATION IN QUANTITY (SUPPLIES).....	70
46.	WALSH-HEALEY PUBLIC CONTRACTS ACT.....	70
	SUPPLEMENTAL PROVISIONS REQUIRED IN FEDERALLY FUNDED CONTRACTS.....	70
47.	ACCESS TO RECORDS.....	70
48.	BUY AMERICA.....	71
49.	CARGO PREFERENCE REQUIREMENTS USE OF UNITED STATES FLAG VESSELS.....	71
50.	CLEAN AIR.....	72

WASHINGTON METROPOLITAN AREA TRANSIT AUTHORITY

SUPPLY AND SERVICE CONTRACT

IFB FQ12235/CPR

51.	CLEAN WATER.....	72
52.	ENERGY CONSERVATION.....	72
53.	FEDERAL CHANGES.....	72
54.	FLY AMERICA REQUIREMENTS.....	72
55.	GOVERNMENT-WIDE DEBARMENT OR SUSPENSION.....	73
56.	INCORPORATION OF FEDERAL TRANSIT ADMINISTRATION (FTA) TERMS.....	73
57.	LOBBYING.....	73
58.	NO OBLIGATION BY THE FEDERAL GOVERNMENT.....	74
59.	PROGRAM FRAUD AND FALSE OR FRAUDULENT STATEMENTS AND RELATED ACTS.....	74
60.	RECOVERED MATERIALS.....	74
61.	RIGHTS IN DATA AND COPYRIGHTS — FTA.....	75
	SPECIAL PROVISIONS.....	93
1.	PERIOD OF PERFORMANCE.....	93
2.	PRICING.....	93
3.	REQUIREMENTS.....	93
4.	PAYMENT TERMS.....	93
5.	AVAILABILITY OF FUNDS FOR THE NEXT FISCAL YEAR.....	93
6.	BILLING AND PAYMENT.....	93
7.	POINT OF CONTACT.....	94
8.	F.O.B. DESTINATION.....	94
9.	CONTRACTOR PERSONNEL.....	95
10.	PRE-EMPLOYMENT CRIMINAL BACKGROUND CHECK REQUIREMENT.....	95
11.	ORDERING.....	96
12.	WARRANTY.....	96
	All costs incurred for the return of rejected fasteners and associated hardware will be at the expense of the successful bidder, Not WMATA. The successful bidder will be responsible for removing any rejected crossties and associated hardware within ten (10) days from the rejection notice.....	96
13.	INDEMNIFICATION.....	96
14.	INSURANCE REQUIREMENTS.....	97
15.	SAFETY/ENVIRONMENTAL REQUIREMENTS.....	99
16.	SANITARY PROVISIONS.....	99
17.	SUBCONTRACTS.....	99
18.	LAWS AND REGULATIONS.....	99
19.	PRIME CONTRACTOR DBE RESPONSIBILITIES.....	100
20.	FEDERAL/LOCAL/STATE SALES TAX.....	100
21.	CONTRACTING OFFICERS TECHNICAL REPRESENTATIVE (COTR).....	101
22.	HAZARDOUS MATERIAL IDENTIFICATION AND MATERIAL SAFETY DATA.....	102
23.	DELIVERY/HANDING INSTRUCTIONS.....	103
24.	PACKAGING AND HANDING INSTRUCTIONS.....	103
25.	FIRST ARTICLE.....	103
26.	RIGHTS IN TECHNICAL DATA - UNLIMITED.....	104
27.	ORGANIZATIONAL CONFLICT OF INTEREST.....	105
28.	LIVING WAGE.....	105
29.	BUY AMERICA ACT.....	106
30.	SITE VISIT/INSPECTION.....	107
31.	GARNISHMENT OF PAYMENTS.....	107

WASHINGTON METROPOLITAN AREA TRANSIT AUTHORITY

SUPPLY AND SERVICE CONTRACT

IFB FQ12235/CPR

32. FORCE MAJEURE CLAUSE	107
33. MULTI YEAR CONTRACTS.....	107
36. METRIC SYSTEM	108
37. NOTIFICATION OF FEDERAL PARTICIPATION	108
38. WHISTLEBLOWER PROTECTION	108
39. DRUG AND ALCOHOL TESTING	110
40. DAVIS-BACON AND COPELAND ANTI-KICKBACK ACTS.....	110
METROPOLITAN WASHINGTON COUNCIL OF GOVERNMENTS RIDER CLAUSE.....	1
TECHNICAL SPECIFICATIONS.....	1
APPENDIX B	1

INTRODUCTORY INFORMATION

SOLICITATION CERTIFICATIONS PAGE

IFB FQ12235/CPR

Direct Fixation Rail Fasteners

APPROVED FOR RELEASE

Project Manager/Office Designee

Date

Contracting Officer

Date

END OF SECTION

DATE: August 14, 2012

SUBJECT: Invitation for Bid (IFB)

Washington Metropolitan Area Transit Authority (WMATA) is seeking bids from qualified firms to provide Direct Fixation Rail Fasteners. NOTE: The IFB contains a **2.5% percent DBE Goal requirement.**

A pre-bid conference will not be held. Your bid must be submitted in accordance with IFB terms and delivered to WMATA's, Office of Procurement and Materials, 600 Fifth Street, N.W., Room 3C02, Washington, DC 20001. ***Bids must be no later than 2:00 P.M. on September 14, 2012.***

If you have any questions, Technical, Contractual or Administrative please email them to the Contract Administrator, Cathy Rooths at crooths@wmata.com no later than 12:00 PM, September 28, 2012. WMATA will provide written answers, by email to all those who obtain the IFB and provide their email addresses.

The following documents are to be submitted with Bidders' bid response:

Required bid documents:

- Bid Form
- Solicitation, Offer & Award Form
- Price Schedule
- Pre Award Survey
- Representations and Certifications
- Specifications
- Certificate of Insurance
- Appendix B

Sincerely,

Kunj Behari
Contracting Officer

**NOTICE TO BIDDERS
IMPORTANT
PLEASE READ CAREFULLY**

To ensure submission of complete bids and to avoid irregularities that could result in a non-responsive bid, please check your bid for each of the following common responsiveness problems:

1. Have you checked your bid? Are all items included and checked for math errors?
2. If Amendments are included, have you acknowledged and recorded the number of Amendments on the bid envelope and Bid Form?
3. Have you signed and submitted the Bid Form Solicitation, Offer & Award page(s)?
4. Have you properly completed and checked the appropriate box for each Certification and Representation? Have you included the Representations and Certifications with your bid?
5. Have you completed and included Pre Award Data?
6. Have you complied with the Appendix B requirement? Met the required 2.5% DBE goal and completed the appropriate DBE forms for submittal with your bid?
7. Contractor's pricing, if offered to other jurisdictions, will be the same regardless of quantities ordered and that the Authority makes no representations regarding the quantities that may be ordered by any such jurisdictions.
8. Bid envelope must be marked with Solicitation number and addressed to the Contract Administrator, Cathy Rooths.
9. Copy of Certificate of Insurance

NOTICE TO ALL VENDORS

Please be advised that effective immediately, all vendors and contractors who have NOT done business with the Washington Metropolitan Area Transit Authority (WMATA) must register in the WMATA Vendor Registration System. Registration is located at <http://www.wmata.com>

New Vendor Registration.

If you are a vendor or contractor and *HAVE* done business with WMATA in the past, please electronically request your company's User ID and Password at <http://www.wmata.com>

Forgot User Id/Password.

Attention to Disadvantaged Business Enterprise (DBE)/Small Business and Local Preference Program (SBLPP) companies:

Minority and women owned businesses who are interested in becoming a WMATA DBE should complete an online DBE application. Self certification is required for Small Business and Local Preference as a part of the Vendor Registration.

Registered Vendor Benefits:

- Visibility to WMATA contract administrators and/or purchasing agents during the purchasing decision period;
- Visibility to other 17,500 registered vendors for possible business opportunities;
- Opportunity to update online, company information such as an e-mail address or contact person on-line;
- Sign up for electronic payment option; and
- Ability to electronically reset User Id and Password.

Any questions regarding registration may be addressed to Vendor Relations at (202) 962-1408 or procurement@wmata.com.

THIS PAGE NOT USED

WASHINGTON METROPOLITAN AREA TRANSIT AUTHORITY

SUPPLY AND SERVICE CONTRACT

IFB FQ12235/CPR

WASHINGTON METROPOLITAN AREA TRANSIT AUTHORITY

SOLICITATION, OFFER AND AWARD

CONTRACT NO. FQ12235	SOLICITATION NO. IFB FQ12235/CPR <input checked="" type="checkbox"/> ADVERTISED <input type="checkbox"/> NEGOTIATED	DATE ISSUED 8/14/12	ADDRESS OFFER TO OFFICE OF PROCUREMENT Office of Procurement 600 Fifth Street NW Washington, DC 20001
-----------------------------	---	----------------------------	--

SOLICITATION

Sealed offer in original and TWO (2) copies for furnishing the supplies or services in the schedules will be received at Authority until 2:00 P.M. local time September 14, 2012
(Hour) (Date)

If this is an advertised solicitation, offers will be publicly opened at that time.

All offers are subject to the following:

1. The Solicitation Instructions which are attached.
2. The General Provisions, which are attached.
3. The Schedule included herein and/or attached hereto.
4. Such other provisions, representations, certifications, and specifications, as are attached or incorporated herein by reference.

Bidder's Phone Number _____

Bidder's Fax Number _____

SCHEDULE

ITEM NO.	SUPPLIES/SERVICES	QUANTITY	UNIT	UNIT PRICE	AMOUNT
	Direct Fixation Rail Fasteners (See continuation of schedule on page 22)				

DUN & BRADSTREET ID NUMBER: _____

OFFEROR

Name and Address (Street, city, county, state, and zip code)	Name and Title of Person Authorized to Sign Offer (Print or Type)
	Signature _____ Offer Date _____
<input type="checkbox"/> Check if remittance is different from above — enter such address in Schedule	

AWARD (To be completed by The Authority)

ACCEPTANCE AND AWARD ARE HEREBY MADE FOR THE FOLLOWING ITEM(S):

ITEM NO.	QUANTITY	UNIT	UNIT PRICE

The total amount of this award is \$ _____

Kunj Behari

Name of Contracting Officer (Print of Type)

WASHINGTON METROPOLITAN TRANSIT AUTHORITY

AWARD DATE

WASHINGTON METROPOLITAN AREA TRANSIT AUTHORITY

SUPPLY AND SERVICE CONTRACT

IFB-FQ12235/CPR

SOLICITATION, OFFER AND AWARD

SCHEDULE OF PRICES

This will be a two (2) year Base Contract with two (2), one (1) year option periods.

Please Note: Options quantities 1, 2 or 3 **MAY** be exercised if the quantity of 15,000 each is not sufficient for that period of time.

Base Year 1

Description	Quantity	Price	Total
Direct Fixation Rail Fasteners	15,000 each	\$	\$
Option 1	5,000 each	\$	\$
Option 2	10,000 each	\$	\$
Option 3	15,000 each	\$	\$

Base Year 2

Description	Quantity	Price	Total
Direct Fixation Rail Fasteners	20,000 each	\$	\$
Option 1	5,000 each	\$	\$
Option 2	10,000 each	\$	\$
Option 3	15,000 each	\$	\$

Option Year 1

Description	Quantity	Price	Total
Direct Fixation Rail Fasteners	20,000 each	\$	\$
Option 1	5,000 each	\$	\$
Option 2	10,000 each	\$	\$
Option 3	15,000 each	\$	\$

Option Year 2

Description	Quantity	Price	Total
Direct Fixation Rail Fasteners	20,000 each	\$	\$
Option 1	5,000 each	\$	\$
Option 2	10,000 each	\$	\$
Option 3	15,000 each	\$	\$

WASHINGTON METROPOLITAN AREA TRANSIT AUTHORITY

SUPPLY AND SERVICE CONTRACT

IFB-FQ12235/CPR

CONTINUATION SHEET

SCHEDULE OF PRICES

Base Year 1 \$ _____

Base Year 2 \$ _____

Option Year 1 \$ _____

Option Year 2 \$ _____

Total Cost \$ _____

WASHINGTON METROPOLITAN AREA TRANSIT AUTHORITY

SUPPLY AND SERVICE CONTRACT

IFB-FQ12235/CPR

ACKNOWLEDGMENT OF AMENDMENTS

The undersigned acknowledges receipt of the following amendments to the Solicitation Documents (Give number and date of each):

Amendment Number____, dated_____

Amendment Number____, dated_____

Amendment Number____, dated_____

Amendment Number____, dated_____

Failure to acknowledge receipt of all amendments may cause the bid to be considered not responsive to the solicitation, which would require rejection of the bid.

DIRECTIONS FOR SUBMITTING BID:

1. Read and comply with the Solicitation Instructions. This form is to be submitted with the Bid Schedule. Attached certifications and Appendix B (DBE/WBE) data must be completed and returned with the bid forms.
2. Representations and Certifications
3. Envelopes containing bids and related required documents must be sealed, marked and addressed as follows:
4. Certificate of Insurance

WASHINGTON METROPOLITAN AREA
TRANSIT AUTHORITY
BID UNDER SOLICITATION FQ12235/CPR
OFFICE OF PROCUREMENT
600 FIFTH STREET
WASHINGTON, DC 20001

BIDS SHALL BE TIMELY MAILED OR HAND DELIVERED TO REACH WMATA BEFORE 2:00 P.M. (LOCAL TIME) ON DAY OF BID OPENING/PROPOSAL CLOSING. BIDS HAND CARRIED BETWEEN 1:00 P.M. AND 2:00 P.M. SHOULD BE PRESENTED TO THE CONTRACT ADMINISTRATOR.

SOLICITATION INSTRUCTIONS

SOLICITATION INSTRUCTIONS

1. DEFINITIONS

As used herein

- a. The term "solicitation" means "Invitation for Bids (IFB)" where the procurement is advertised, and "Request for Proposal (RFP)" where the procurement is negotiated.
- b. The term "offer" means "bid" where the procurement is advertised and "proposal" where the procurement is negotiated.

2. EXPLANATION TO BIDDER

- a. Any explanation desired by a bidder regarding the meaning or interpretation of this Invitation for Bid, specifications, drawings, and other bidding documents must be requested in writing and with sufficient time allowed for a reply to reach all bidders before the time set for the opening of bids.
- b. Any interpretation made will be in the form of an amendment of this Invitation for Bid, specifications, or other bidding documents and will be furnished to all prospective bidders.
- c. Oral explanations or instructions given before the award of the contract will not be binding.

3. PRIOR REPRESENTATIONS

The Authority assumes no responsibility for any understanding or representations concerning this solicitation made by any of its officers or agents prior to the issuance of the solicitation, the scope of work, or related documents.

4. PRE-BID MEETING

There will not be a pre-bid meeting for this requirement.

5. REVISIONS PRIOR TO DATE SET FOR RECEIPT OF BIDS

- a. The right is reserved by the Authority to revise or amend the scope of work and/or drawings prior to the date set for the opening of bids. Such revisions and amendments, if any, will be announced by an amendment or amendments to this Invitation for Bid. Copies of such amendments as may be issued will be furnished to all prospective bidders.
- b. If the revisions and amendments require material changes in quantities or prices bid, or both, the date set for the opening of bids may be postponed by such number of days as in the opinion of the Authority will enable bidders to revise their bids. In such cases, the amendment will include an announcement of the new date for the opening of bids.

6. ACKNOWLEDGMENT OF AMENDMENTS

- a. Offerors are required to acknowledge receipt of all amendments to this Invitation on the Bid Form in the space provided, or by separate letter or telegram prior to opening of bids.
- b. Failure to acknowledge all amendments may cause the bid to be considered not responsive to the invitation, which would require rejection of the bid. The outside of the envelope containing the offer shall also be marked to show the amendments received.

7. PREPARATION OF BIDS

- a. Bids shall be submitted on the Bid Forms furnished, or copies thereof, and must be manually signed. If erasures or other changes appear on the forms, such erasures or changes must be initialed by the person signing the bid. Unless specifically authorized in this Invitation for Bid, telegraphic bids will not be considered.
- b. The Bid Form may provide for submittals of a price or prices for one or more items which may be lump sum bids, alternate prices, scheduled items resulting in a bid on a unit of construction or a combination thereof, or other bidding arrangements. **Where the Bid Form explicitly requires that the bidder bid on all items, failure to do so will disqualify the bid.** When submittal of a price on all items is not required, bidders shall insert the words NO BID in the space provided for any item on which no price is submitted.
- c. Unless specifically called for, alternate bids will not be considered.
- d. Modifications of bids already submitted will be considered if received at the office designated in this Invitation for Bid by the time set for the opening of bids. Telegraphic modifications will be considered, but not reveal the amount of the original or revised bid. Neither telegraphic nor teletype facilities are located in the offices of the Authority.

8. SUBMITTAL OF BIDS

- a. Offers and modifications thereof shall be enclosed in sealed envelopes and addressed to the office specified in the solicitation. The Offeror shall show the hour and date specified in the solicitation for receipt, the solicitation number, and the name and address of the Offeror on the face of the envelope.
- b. Telegraphic offers will not be considered unless authorized by the solicitation; however, offers may be modified or withdrawn by written or telegraphic notice, provided such notice is received prior to the hour and date specified for receipt.
- c. Facsimile offers, modifications or withdrawals will not be considered unless authorized by the Authority.

9. LATE BIDS AND MODIFICATIONS OR WITHDRAWALS

- a. Any offer received at the office designated in the solicitation after the exact time specified for receipt will not be considered unless it is received before award is made and it--
- (1) Was sent by registered or certified U.S. mail not later than the fifth calendar day before the date specified for receipt of offers (e.g., an offer submitted in response to a solicitation requiring receipt of offers by the 20th of the month must have been sent by registered mail by the 15th);
 - (2) Was sent by mail or, if authorized by the solicitation, was sent by telegram or via facsimile and it is determined by the Authority that the late receipt was due solely to mishandling by the Authority after receipt;
 - (3) Was sent by U.S. Postal Service Express Mail Next Day Service Post Office to Addressee, not later than 5:00 p.m. at the place of mailing two working days prior to the date specified for receipt of offers. The term "working days" excludes weekends and U.S. Federal holidays; or
 - (4) Is the only offer received.
- b. Any modification of an offer, except a modification resulting from the Contracting Officer or other delegated Authority's Representative's request for "best and final" offer, is subject to the same conditions as in subparagraphs (a)(1), (2), and (3) of this provision.
- c. A modification resulting from the Contracting Officer or other delegated Authority's Representative's request for "best and final" offer received after the time and date specified in the request will not be considered unless received before award and the late receipt is due solely to mishandling by the Authority.
- d. The only acceptable evidence to establish the date of mailing of a late offer, modification, or withdrawal sent by registered or certified mail is the U.S. or Canadian Postal Service postmark on the envelope or wrapper and on the original receipt from the U.S. or Canadian Postal Service. Both postmarks must show a legible date or the offer, modification or withdrawal shall be processed as if mailed late. "Postmark" means a printed, stamped, or otherwise placed impression (exclusive of a postage meter machine impression) that is readily identifiable without further action as having been affixed by employees of the U.S. or Canadian Postal Service on the date of mailing. Therefore, Offerors should request the postal clerk to place a legible hand cancellation bull's eye postmark on both the receipt and the envelope or wrapper.
- e. The only acceptable evidence to establish the time of receipt by the Authority is the time/date stamp of that installation on the proposal wrapper or other documentary evidence of receipt maintained by the Authority.

WASHINGTON METROPOLITAN AREA TRANSIT AUTHORITY

SUPPLY AND SERVICE CONTRACT

IFB-FQ12235/CPR

- f. The only acceptable evidence to establish the date of mailing of a late offer, modification, or withdrawal sent by Express Mail Next Day Service-Post Office to Addressee is the date entered by the post office receiving clerk on the "Express Mail Next Day Service-Post Office to Addressee" label and the postmark on both the envelope or wrapper and on the original receipt from the U.S. Postal Service. "Postmark" has the same meaning as defined in paragraph d. of this provision, excluding postmarks of the Canadian Postal Service. Therefore, Offerors or bidders should request the postal clerk to place a legible hand cancellation bulls eye postmark on both the receipt and the envelope or wrapper.
- g. Notwithstanding paragraph "a" above, a late modification of any otherwise successful offer that makes its terms more favorable to the Authority will be considered at any time it is received and may be accepted.
- h. Offers may be withdrawn by written notice or telegram (including mailgram) received at any time before award. If the solicitation authorizes facsimile offers, offers may be withdrawn via facsimile received at any time before award, subject to the conditions specified in the provision entitled "Facsimile Offers". Offers may be withdrawn in person by an Offeror or an authorized representative, if the representative's identity is made known and the representative signs a receipt for the offer before award.

10. MINIMUM BID ACCEPTANCE PERIOD

- a. "Acceptance period," as used in this provision, means the number of calendar days available to WMATA for awarding a contract from the date specified in this solicitation for receipt of bids.
- b. This provision supersedes any language pertaining to the acceptance period that may appear elsewhere in this solicitation.
- c. WMATA requires a minimum acceptance period of **90 calendar days from latest revised date.**

11. CONTRACT AWARD

If this solicitation is an Invitation for Bids:

- a. The Authority may (1) reject any or all bids, (2) accept other than the lowest bid, and (3) waive minor informalities and irregularities in bids received.
- b. A written award or acceptance of a bid mailed or otherwise furnished to the successful bidder within the time of acceptance specified in the bid shall result in a binding contract without further action by either party.
- c. The Authority may reject a bid as non-responsive if the prices bid are materially unbalanced between line items or subline items. A bid is materially unbalanced when it is based on prices significantly less than cost for some work and prices which are significantly overstated in relation to cost for other work, and if there is a reasonable doubt that the bid will result in the lowest overall cost to the

Authority even though it may be the low evaluated bid, or it is so unbalanced as to be tantamount to allowing an advance payment.

12. PRE-AWARD INFORMATION

(To be included with Bid response)

- a. The Contracting Officer or other delegated Authority's Representative may conduct a pre-award survey to determine if the bidder eligible for award is responsible both financially and technically and has the capability to perform the work of the Contract in accordance with the requirements of the Specifications and within the time or times specified.
- b. Accordingly, the apparent lowest responsive bidder shall furnish the following when requested by the Contracting Officer:
 - (1) A completed and signed Pre-Award Evaluation Data form, including, but not limited to, the following: A statement of the Offeror's experience record, the type of concerns for which the Offeror conducts business and a list of contracts, if any, on which failure to complete within the specified time resulted in the assessment of liquidated damages.

The low bidder will be required to demonstrate its ability to perform services contained in the solicitation, in a timely manner, to the complete satisfaction of the Authority. The Authority may reject the bidder as non-responsible. If the low bidder is eliminated, then the second lowest bidder will be required to demonstrate its ability to perform services as described herein. This process will continue to the next lowest bidder until a bidder successfully meets the specification requirements.
 - (2) Financial Statements

Complete financial statements for the last two years, including Statement of Financial Position (Balance Sheet), Results of Operations (Income Statement), Statement of Changes in Financial Position (Net Change in Resources) and Statement of Current and Retained Earnings. These statements shall be certified indicating disclosure of all facts which could impair or affect the statements presented.
 - (3) Disadvantaged Business Enterprise data as set forth in Appendix B. Note: The submittal of certain items and request for waiver (if applicable) with the bid is required if offer is \$100,000 or greater. Failure to submit forms B-12, B-13, and/or request for waiver (if applicable) may cause the bid to be found unacceptable and subsequently rejected.
- c. Doubt as to technical ability, productive capability, "good faith effort - DBE," and financial strength which cannot be resolved affirmatively may result in a determination of non-responsibility by the Contracting Officer.

13. EQUAL EMPLOYMENT OPPORTUNITY

Contractor will be required to comply with all applicable Equal Employment Opportunity laws and regulations.

14. OPPORTUNITY FOR DISADVANTAGED BUSINESS ENTERPRISES TO BID

It is the policy of the Authority (WMATA), the Federal Transit Administration (FTA) and the U.S. Department of Transportation (US DOT) that Disadvantaged Business Enterprises (DBE's) shall have an equal opportunity to receive and participate in performing federally assisted contracts, including contracts and subcontracts at any tier.

15. REPRESENTATIONS, CERTIFICATIONS, AND ACKNOWLEDGMENTS

The Offeror shall check or complete all applicable boxes or blocks on the attached "Representations and Certifications" form.

- a. Ineligible Offeror. All Offerors will be required to certify that they are not on the Comptroller General's list of ineligible bidders.
- b. Parent Company. A parent company for the purposes of this offer is a company which either owns or controls the activities and basic business policies of the Offeror. To own another company means the parent company must own at least a majority (more than 50 percent) of the voting rights in that company. To control another company, such ownership is not required; if another company is able to formulate, determine, or veto basic business policy decisions of the Offeror, such other company is considered the parent company of the Offeror. This control may be exercised through the use of dominant minority voting rights, use of proxy voting, contractual arrangements, or otherwise.
- c. Employer's Identification Number (E.I. No.). The Offeror shall insert in the applicable space on the form, if it has no parent company, its own E.I. No. (Federal Social Security Number used on the Employer's Quarterly Federal Tax Return, U.S. Treasury Department Form 941), or, if it has a parent company, the E.I. No. of its parent company.

16. AWARD - SINGLE AWARD FOR ALL ITEMS

The Authority will make a single award for all line items in the Schedule unless specified elsewhere.

17. NOTICE OF PROTEST POLICY

- a. WMATA policy and procedure for the administrative resolution of protests is set forth in Chapter 20 of the Procurement Policy Manual (PPM). The PPM contains strict rules for filing a timely protest, for responding to a notice that a protest has been filed, and other procedural matters. The Contracting Officer or other delegated Authority's Representative can furnish a copy of Chapter 20 upon request.

- b. FTA Circular 4220.1F, Chapter VII-1, addresses Bid Protests. FTA will only review protests regarding the alleged failure of the grantee to have a written protest procedure or alleged failure to follow such procedures, and only when submitted by an interested party. The term "interested party" is defined in the Authority's policy for handling protests.
- c. Alleged violations on other grounds must be submitted to the Contracting Officer or other delegated Authority's Representative who will decide the protest.
- d. The judicial authorities having jurisdiction over court actions concerning protest decisions are the United States District Courts for the Districts of Maryland, Virginia, and the District of Columbia, and the local courts in Maryland, Virginia, and the District of Columbia.

18. REQUIREMENT FOR COST DATA FOR CONTRACT AWARD

In the event there is inadequate competition as a result of this solicitation, the Authority may require each bidder to submit cost data in sufficient detail to permit analysis of the cost elements which make up the bid prices. If there is a sole bid, and the bid is over \$100,000, the bid may be subject to audit.

19. BASIS FOR AWARD

- a. The Authority will award a contract to the lowest responsive and responsible bidder whose bid conforms to this Invitation for Bids is determined to be the most advantageous to the Authority, considering only price and price related factors included in the IFB.
- b. If, after receipt of the bids, the Contracting Officer determines that adequate price competition does not exist, the Offeror shall provide certified cost or pricing data as requested by the Contracting Officer.

20. WMATA'S TAX EXEMPT STATUS

- a. Pursuant to Article XVI, Paragraph 78, of the Washington Area Metropolitan Transit Authority Compact, as adopted by the State of Maryland, the District of Columbia, and the Commonwealth of Virginia, with the authorization and consent of the Congress of the United States, the Authority has been accorded exemption from taxes as follows:

"The Authority and the Board shall not be required to pay taxes or assessments upon any of the property acquired by it or under its jurisdiction, control, possession or supervision, or upon its activities in the operation and maintenance of any transit facility or upon any revenues there from, and the property and income derived there from shall be exempted from all Federal, State, District of Columbia, municipal, and local taxation. This exemption shall include without limitation, all motor vehicle license fees, sales taxes and motor fuel taxes."

- b. It has been the practice of the District of Columbia to apply the Authority's tax exempt status to certain purchases of materials required under Authority construction contracts and acquired by contractors for physical incorporation into the project work. This has not been the practice in either Maryland or Virginia. The Authority does not represent or warrant that the District of Columbia practice applies to this project or, if it does, that it will continue in effect during the term of this project. It is the responsibility of the Contractor to determine its liability for any and all taxes applicable to this project. Assessment or payment of taxes by the Contractor, including taxes resulting from changes in existing laws or the application thereof or of new or additional taxes, shall not constitute the basis for an increase in the Contract price, except as otherwise allowed under the General Provisions Article, FEDERAL, STATE AND LOCAL TAXES, of this Contract.
- c. By submission of its bid, the bidder certifies that none of the taxes as to which the Authority is exempt are included in its bid price(s).

21. CONTRACTOR PERFORMANCE EVALUATION

22. TYPE OF CONTRACT

The Authority contemplates award of a ***Indefinite Delivery, Indefinite Quantity Contract (IDIQ) Firm Fixed Price Contract*** resulting from this solicitation.

23. ENGLISH LANGUAGE AND UNITED STATES CURRENCY

As regards this solicitation and the resultant contract:

- a. All communications (oral, written, electronic and otherwise including but, not limited to software coding) shall be in the English language.
- b. All pricing shall be in United States dollars.

24. BRAND NAME OR EQUAL

- a. If items called for by this Invitation for Bid have been identified in the Schedule by a "brand name or equal" description, such identification is intended to be descriptive, but not restrictive, and is to indicate the quality and characteristics of products that will be satisfactory. Bids offering "equal" products including products of the brand name manufacturer other than the one described by brand name will be considered for award if such products are clearly identified in the proposals and are determined by the Authority to meet fully the salient characteristics requirements in the Invitation for Bids.
- b. Unless the bidder clearly indicates in his bid that he is offering an "equal" product, his proposal shall be considered as offering a brand name product referenced in the Invitation for Bid.
- c.(1) If the bidder proposes to furnish an "equal" product, the brand name, if any, of the product to be furnished in the space provided in the Invitation for Bid, or such

WASHINGTON METROPOLITAN AREA TRANSIT AUTHORITY

SUPPLY AND SERVICE CONTRACT

IFB-FQ12235/CPR

product shall be otherwise clearly identified in the bid. The evaluation of bids and the determination as to equality of the product offered shall be the responsibility of the Authority and will be based on information reasonable available to the Department of Procurement.

CAUTION TO BIDDERS. WMATA is not responsible for locating or securing any information which is not identified in the proposal and reasonably available to the Authority. Accordingly, to insure that sufficient information is available, the bidder must furnish as a part of his bid all descriptive material (such as cuts, illustrations, drawings, or other information) necessary for the Authority to determine whether the product offered meets the requirements of the Invitation for Bid.

25. FEDERAL/LOCAL/STATE SALES TAX

- a. The Authority is exempt under this solicitation from all Federal, State and District of Columbia, municipal and local taxation.
- b. This provision supersedes any language pertaining to payment of taxes that may appear elsewhere in this solicitation.
- c. The Authority's tax exempt numbers are as follows: District of Columbia -- 5611-0082187-001; Maryland -- 30072210; Virginia -- 5280-0067.

**REPRESENTATIONS AND CERTIFICATIONS
(FEDERALLY FUNDED SUPPLY/SERVICE/CONSTRUCTION CONTRACTS)**

REPRESENTATIONS

Instructions: Check or complete all applicable boxes or blocks on this form and submit it with your offer.

1. TYPE OF BUSINESS ORGANIZATION (RC-101, MAY 07)

By submission of this offer, the offeror represents that it operates as an individual, a partnership, a limited liability company, a joint venture, a nonprofit organization, or a corporation, incorporated under the laws of the State of _____.

2. AFFILIATION AND IDENTIFYING DATA (RC-102, MAY 07)

Each offeror shall complete (a), (b) if applicable, and (c) below, representing that:

- (a) It is, is not, owned or controlled by a parent company. For this purpose, a parent company is defined as one which either owns or controls the activities and basic business policies of the offeror. To own another company means the parent company must own at least a majority, i.e., more than 50 percent, of the voting rights in that company. To control another company, such ownership is not required; if another company is able to formulate, determine or veto basic business policy decisions of the offeror, such other company is considered the parent of the offeror. This control may be exercised through the use of dominant minority voting rights, use of proxy voting, contractual arrangements or otherwise.
- (b) If the offeror is owned or controlled by a parent company, it shall insert in the space below the name and main office address of the parent company:

Name of Parent Company

Main Office Address (including ZIP Code)

- (c) If the offeror has no parent company, it shall provide in the applicable space below its own Employer's Identification Number (E.I.N.), (i.e., number used on Federal Tax Returns or, if it has a parent company, the E.I. No. of its parent company).

Offeror E.I. Number: _____ or, Parent Company's E.I. Number: _____

- (d) If a Data Universal Numbering Systems (DUNS), number has not been established for the address entered on the Solicitation, Offer, and Award Form, the Authority will arrange for the assignment of this number after award of a contract and will notify the Contractor accordingly.

3. PREVIOUS CONTRACTS AND COMPLIANCE REPORTS (RC-103, MAY 07)

This representation is applicable to federally assisted contracts. By submission of this offer, the offeror represents that:

- (a) It has, has not, participated in a previous contract or subcontract subject to either the Equal Opportunity Clause of this solicitation, or the clause contained in Parts II and IV of Executive Order 11246, as amended; which prohibits discrimination on the basis of race, color, creed, national origin, sex, age; and
- (b) It has, has not, filed all required compliance reports; and
- (c) Representations indicating submittal of required compliance reports signed by proposed subcontractors will be obtained prior to subcontract awards.

4. DISADVANTAGED BUSINESS ENTERPRISE (RC-104, MAY 07)

This representation is applicable to federally assisted contracts. By submission of this offer, the offeror represents that:

WASHINGTON METROPOLITAN AREA TRANSIT AUTHORITY

SUPPLY AND SERVICE CONTRACT

IFB-FQ12235/CPR

- (a) It [] is, [] is not, a disadvantaged business enterprise.

"Disadvantaged Business Enterprise" means a for-profit small business concern that is at least 51% owned by one or more individuals who are both socially and economically disadvantaged individuals or, in the case of a corporation, in which 51% of the stock is owned by one or more such individuals; and whose management and daily business operations are controlled by one or more socially and economically disadvantaged individuals who own it.

"Socially and Economically Disadvantaged Individuals" is defined in Appendix B, Section 4, paragraph I; and

- (b) It [] is, [] is not, currently certified by WMATA as a disadvantaged business enterprise.

5. AFFIRMATIVE ACTION COMPLIANCE (RC-105, MAY 07)

This representation is applicable to federally assisted contracts of \$50,000 or more that are awarded to contractors with 50 or more employees. By submission of this offer, the offeror represents that:

- (a) It has a workforce of employees.
- (b) It [] has developed and has on file, or [] has not developed and does not have on file, at each establishment, affirmative action programs required by the rules and regulations of the Secretary of Labor (41 CFR Parts 60-1 and 60-2), or
- (c) It [] has not previously had contracts subject to the written affirmative action program requirements of the rules and regulations of the Secretary of Labor.

CERTIFICATIONS

6. COVENANT AGAINST GRATUITIES (RC-106, MAY 07)

By submission of this offer, the offeror certifies, and in the case of a joint offer, each party thereto certifies as to its own organization, that in connection with this procurement:

Neither it nor any of its employees, representatives or agents have offered or given gratuities (in the form of entertainment, gifts or otherwise) to any director, officer or employee of the Authority with the view toward securing favorable treatment in the awarding, amending, or the making of any determination with respect to the performing of the contract.

7. CONTINGENT FEE (RC-107, MAY 07)

By submission of this offer, the offeror certifies, and in the case of a joint offer, each party thereto certifies as to its own organization, that in connection with this procurement:

- (a) It [] has, [] has not, employed or retained any company or persons (other than a full-time, bona fide employee working solely for the offeror) to solicit or secure this contract, and
- (b) It [] has, [] has not, paid or agreed to pay any company or person (other than a full-time, bona fide employee working solely for the offeror) any fee, commission, percentage, or brokerage fee contingent upon or resulting from the award of this contract.

8. CLEAN AIR AND WATER CERTIFICATION (RC-108, MAY 07)

This certification is applicable if the contract will be federally assisted and the offer exceeds \$100,000, or the Contracting Officer believes that orders under an indefinite contract in any year will exceed \$100,000 or a facility to be used has been the subject of a conviction under the Clean Air Act (42 U.S.C. 7413(c)(1)) or the Water Act (33 U.S.C. 1319(c)) and is listed by the U.S. Environmental Protection Agency (EPA) as a violating facility, and the acquisition is not otherwise exempt:

- (a) Any facility to be utilized in the performance of this proposed contract [] is, or [] is not listed on the EPA list of Violating Facilities;

WASHINGTON METROPOLITAN AREA TRANSIT AUTHORITY

SUPPLY AND SERVICE CONTRACT

IFB-FQ12235/CPR

- (b) Offeror will immediately notify the Contracting Officer, before award, of the receipt of any communications from the Administrator, or a designee of the EPA, indicating that any facility which it proposes to use for the performance of the contract is under consideration to be listed on the EPA List of Violating Facilities; and
- (c) Offeror will include a certification substantially the same as this certification, including this paragraph, in every non-exempt subcontract.

9. DEBARMENT, SUSPENSION, INELIGIBILITY, AND VOLUNANTARY EXLCUSION (RC-109, MAY 07)

This certification is applicable to federally assisted contracts over \$25,000.

- (a) Primary Covered Transactions. This certification applies to the offer submitted in response to this solicitation and will be a continuing requirement throughout the term of any resultant contract.
 - (1) In accordance with the provisions of Appendix A to 49 Code of Federal Regulations (CFR) Part 29, the offeror certifies to the best of its knowledge and belief that it and its principals:
 - (i) are not currently debarred, suspended, proposed for debarment, declared ineligible, or voluntarily excluded from covered transactions by any Federal or State department or agency;
 - (ii) have not, within a three-year period preceding this offer, been convicted of or had a civil judgment rendered against them for commission of fraud or a criminal offense in connection with obtaining, attempting to obtain, or performing a public (Federal, State, or local) transaction or contract under a public transaction; violation of Federal or State antitrust statutes, or commission of embezzlement, theft, forgery, bribery, falsification or destruction of records, making false statements, or receiving stolen property;
 - (iii) are not currently indicted for or otherwise criminally or civilly charged by a governmental entity (Federal, State, or local) with commission of any of the offenses enumerated in paragraph (1)(ii) of this Certification; and
 - (iv) have not, within a three-year period preceding this offer, had one or more public transactions (Federal, State, or local) terminated for cause or default.
 - (2) Where the offeror is unable to certify to any of the statements in this certification, the offeror shall attach an explanation to this offer.
- (b) Lower Tier Covered Transactions. This certification applies to a subcontract at any tier expected to equal or exceed \$25,000 and will be a continuing requirement throughout the term of the prime contract.
 - (1) In accordance with the provisions of Appendix B to 49 Code of Federal Regulations (CFR) Part 29, the prospective lower tier subcontractor certifies, by submission of this offer, that neither it nor its principals is currently debarred, suspended, proposed for debarment, declared ineligible, or voluntarily excluded from participation in this transaction by any Federal or State department or agency.
 - (2) Where the prospective lower tier subcontractor is unable to certify to any of the statements in this certification, such prospective participant shall attach an explanation to this proposal.
- (c) The Certification required by subparagraph (b), above, shall be included in all applicable subcontracts and a copy kept on file by the prime contractor. The prime contractor shall be required to furnish copies of certifications to the Contracting Officer upon the Contracting Officer's request.

10. CERTIFICATION OF INDEPENDENT PRICE DETERMINATION (RC-110, MAY 07)

- (a) By submission of this offer, the offeror certifies, and in the case of a joint offer, each party thereto certifies as to its own organization, that in connection with this procurement:

WASHINGTON METROPOLITAN AREA TRANSIT AUTHORITY

SUPPLY AND SERVICE CONTRACT

IFB-FQ12235/CPR

- (1) The prices in this offer have been arrived at independently, without, for the purpose of restricting competition, any consultation, communication, or agreement with any other offeror or with any other competitor, as to any matter relating to such prices;
 - (2) Unless otherwise required by law, the prices which have been quoted in this offer have not been knowingly disclosed by the offeror and will not be knowingly disclosed by the offeror prior to the opening of bids (in the case of a sealed bid solicitation) or prior to award (in the case of a negotiated procurement), directly or indirectly, to any other offeror or to any competitor; and
 - (3) No attempt has been made or will be made by the offeror to induce any other person or firm to submit or not to submit an offer for the purpose of restricting competition.
- (b) Each person signing this offer certifies that:
- (1) He or she is the person in the offeror's organization responsible within that organization for the decision as to the prices being offered herein and that he/she has not participated, and will not participate, in any action contrary to (a)(1) through (a)(3) above; or
 - (2) He or she is not the person in the offeror's organization responsible within that organization for the decision as to the prices being offered herein, but that he/she has been authorized in writing to act as agent for the persons responsible for such decision in certifying that such persons have not participated; and will not participate, in any action contrary to (a)(1) through (a)(3) above, and as their agent does hereby so certify.

11. CERTIFICATION OF NONSEGREGATED FACILITIES (RC-111, MAY 07)

This certification is applicable to federally assisted contracts over \$10,000.

- (a) By submission of this offer, the offeror certifies, and in the case of a joint offer, each party thereto certifies as to its own organization, that in connection with this procurement:
- (1) It does not and will not maintain or provide for its employees any segregated facilities at any of its establishments, and that it does not and will not permit its employees to perform their services at any location under its control, where segregated facilities are maintained.
 - (2) The offeror agrees that a breach of this certification is a violation of the Equal Opportunity Clause in the contract.
 - (3) As used in this certification, the term "segregated facilities" means any waiting rooms, work areas, rest rooms and wash rooms, restaurants and other eating areas, time clocks, locker rooms and other storage or dressing areas, parking lots, drinking fountains, recreation or entertainment areas, transportation, and housing facilities provided for employees which are segregated by explicit directive or are in fact segregated on the basis of race, color, religion or national origin, because of habit, local custom or otherwise.
 - (4) It further agrees that (except where it has obtained identical certifications from proposed subcontractors for specific time periods) it will:
 - (a) Obtain identical certifications from proposed subcontractors before the award of subcontracts under which the subcontractor will be subject to the Equal Opportunity clause;
 - (b) Retain such certifications in its files; and
 - (c) Forward the following notice to such subcontractors (except if the proposed subcontractors have submitted identical certifications for specific time periods):

WASHINGTON METROPOLITAN AREA TRANSIT AUTHORITY

SUPPLY AND SERVICE CONTRACT

IFB-FQ12235/CPR

**NOTICE TO PROSPECTIVE SUBCONTRACTORS OF REQUIREMENTS FOR CERTIFICATION
OF NONSEGREGATED FACILITIES**

A Certification of Nonsegregated Facilities must be submitted prior to award of a subcontract exceeding \$10,000 which is not exempt from the provisions of the Equal Opportunity clause. The certification may be submitted either for such subcontract or for all subcontracts during a period (i.e., quarterly, semiannually or annually).

12. NONDISCRIMINATION ASSURANCE (RC-112, MAY 07)

By submission of this offer, the offeror certifies, and in the case of a joint offer, each party thereto certifies as to its own organization, in connection with this procurement that it will not discriminate on the basis of race, color, creed, national origin, sex, age in the performance of this contract. The offeror is required to insert the substance of this clause in all subcontracts and purchase orders. Failure by the contractor to carry out these requirements is a material breach of this contract, which may result in the termination of this contract or such other remedy as the Authority deems appropriate. The offeror further agrees by submitting this offer that it will include this certification, without modification, in all subcontracts and purchase orders.

13. CERTIFICATION OF RESTRICTIONS ON LOBBYING (RC-113, MAY 07)

This certification is applicable to federally assisted contracts if the offer exceeds \$100,000.

- (a) By submission of this offer, the offeror certifies, and in the case of a joint offer, each party thereto certifies as to its own organization, that to the best of his or her knowledge or belief:
 - (1) No Federal appropriated funds have been paid or will be paid, by or on behalf of the undersigned, to any person for influencing or attempting to influence an officer or employee of an agency, a Member of Congress, an officer or employee of Congress, or an employee of a Member of Congress in connection with the awarding of any Federal contract, the making of any Federal grant, the making of any Federal loan, the entering into of any cooperative agreement, and the extension, continuation, renewal, amendment, or modification of any Federal contract, grant, loan, or cooperative agreement.
 - (2) If any funds other than Federal appropriated funds have been paid or will be paid to any person for making lobbying contacts to an officer or employee of any agency, a Member of Congress, an officer or employee of Congress, or an employee of a Member of Congress in connection with this contract, the undersigned shall complete and submit Standard Form--LLL, "Disclosure of Lobbying Activities."
 - (3) The undersigned shall require that the language of this certification be included in the award documents for all subawards at all tiers and that all subrecipients shall certify and disclose accordingly.
- (b) This certification is a material representation of fact upon which reliance was placed when this transaction was made or entered into. Submission of this certification is a prerequisite for making or entering into this transaction imposed by 31 U.S.C. § 1352, as amended. Any person who fails to file the required certification shall be subject to a civil penalty of not less than \$10,000 and not more than \$100,000 for each such failure.

14. BUY AMERICA ACT CERTIFICATION (RC-114, MAY 07)

The Buy America requirements apply to federally assisted construction contracts, and acquisition of goods or rolling stock contracts valued at more than \$100,000.

- (a) By submission of this offer, the offeror certifies, and in the case of a joint offer, each party thereto certifies as to its own organization, that in connection with this procurement it will comply with 49 U.S.C. 5323(j) and 49 C.F.R. Part 661, which provide that Federal funds may not be obligated unless steel, iron, and manufactured products used in FTA-funded projects are produced in the United States, unless a waiver has been granted by FTA or the product is subject to a general waiver. General waivers are listed in 49 C.F.R. 661.7 Separate requirements for rolling stock are set out at 49 U.S.C. 5323(j)(2)(C) and 49 C.F.R. 661.11.
- (b) An offeror must submit to the Authority the appropriate Buy America certification (below) with all bids or offers on FTA-funded contracts, except those subject to a general waiver. Offers that are

WASHINGTON METROPOLITAN AREA TRANSIT AUTHORITY

SUPPLY AND SERVICE CONTRACT

IFB-FQ12235/CPR

not accompanied by a completed Buy America certification must be rejected as nonresponsive. This requirement does not apply to lower tier subcontractors. Mark the applicable certifications below:

(1) **Certification requirement for procurement of steel, iron, or manufactured products:**

Certificate of Compliance with 49 U.S.C. 5323(j)(1)

The bidder or offeror hereby certifies that it will meet the requirements of 49 U.S.C. 5323(j)(1) and the applicable regulations in 49 CFR Part 661.5.

Certificate of Non-Compliance with 49 U.S.C. 5323(j)(1)

The bidder or offeror hereby certifies that it cannot comply with the requirements of 49 U.S.C. 5323(j)(1) and 49 C.F.R. 661.5, but it may qualify for an exception pursuant to 49 U.S.C. 5323(j)(2)(A), 5323(j)(2)(B), or 5323(j)(2)(D), and 49 C.F.R. 661.7.

(2) **Certification requirement for procurement of buses, other rolling stock and associated equipment:**

Certificate of Compliance with 49 U.S.C. 5323(j)(2)(C).

The bidder or offeror hereby certifies that it will comply with the requirements of 49 U.S.C. 5323(j)(2)(C) and the regulations at 49 C.F.R. Part 661.11.

Certificate of Non-Compliance with 49 U.S.C. 5323(j)(2)(C)

The bidder or offeror hereby certifies that it cannot comply with the requirements of 49 U.S.C. 5323(j)(2)(C) and 49 C.F.R. 661.11, but may qualify for an exception pursuant to 49 U.S.C. 5323(j)(2)(A), 5323(j)(2)(B), or 5323(j)(2)(D), and 49 C.F.R. 661.7.

15. CERTIFICATION OF NON-DELINQUENT TAXES (RC-116, OCTOBER 2008)

This certification is applicable to federally assisted contracts.

(a) By submission of this offer, the offeror certifies, and in the case of a joint offer, each party thereto certifies as to its own organization, that in connection with this procurement:

(1) It has not been convicted over the past three years of violating any federal criminal tax law or failed to pay any tax.

(2) It has certified if it has been notified of an unresolved tax lien or any unsatisfied federal tax delinquency in excess of \$3,000 and that it is paying tax debts through an installment agreement or have requested a collection due process hearing.

(3) The offeror agrees that a breach of this certification is a violation of the Federal Acquisition Regulation.

(4) As used in this certification, the term "tax delinquency" means an outstanding debt for which a notice of lien has been filed in public records.

(5) It further agrees that (except where it has obtained identical certifications from proposed subcontractors for specific time periods) it will:

(a) Obtain identical certifications from proposed subcontractors before the award of subcontracts under which the subcontractor will be subject to Federal Acquisition Regulation;

(b) Retain such certifications in its files; and

(c) Forward the following notice to such subcontractors (except if the proposed subcontractors have submitted identical certifications for specific time periods):

WASHINGTON METROPOLITAN AREA TRANSIT AUTHORITY

SUPPLY AND SERVICE CONTRACT

IFB-FQ12235/CPR

**NOTICE TO PROSPECTIVE SUBCONTRACTORS OF REQUIREMENTS FOR CERTIFICATIONS
OF NON-DELINQUENT TAXES**

A Certification of Non-Delinquent Taxes must be submitted prior to award of a subcontract exceeding \$100,000 which is not exempt from the provisions of Federal Acquisition Regulation. The certification may be submitted either for such subcontract or for all subcontracts during a period (i.e., quarterly, semiannually or annually).

SIGNATURE BLOCK FOR ALL REPRESENTATIONS AND CERTIFICATIONS		
Name of Offeror: _____		
Name and Title of Authorized Representative: _____		
_____		_____
Print and Sign Name		
_____	_____	_____
Title		Date

(RC-116, OCTOBER 08)

THIS PAGE NOT USED

WASHINGTON METROPOLITAN AREA TRANSIT AUTHORITY

SUPPLY AND SERVICE CONTRACT

IFB-FQ12235/CPR

PRE-AWARD EVALUATION DATA
PROJECT DESCRIPTION: Direct Fixation Rail Fasteners

1. Name of Firm: _____

2. Address: _____

3. Individual Partnership Corporation Joint Venture
4. Date Organized _____
State in which incorporated _____
5. Names and Addresses of Officers or Partners:
 - a. _____
 - b. _____
 - c. _____
 - d. _____
 - e. _____
 - f. _____
6. How long has your firm been in business under its present name? _____
7. Attach as SCHEDULE ONE a list of current contracts, which demonstrates your proficiency, each with contract amount, name of contracting party, type of work and percentage of completion.
8. Attached as SCHEDULE TWO a list of similar contracts, each with contract amount, name of contracting party, and character or type of work for similar contract completed in the last two (2) years.
9. In the last two (2) years, have you ever been denied an award where you were low bidder/offer? If the answer is YES, attach as SCHEDULE THREE the full particulars regarding each occurrence.
10. Have you ever failed to complete any contract, other than current, on which you were the low bidder?

If the answer is YES, attach as SCHEDULE FOUR, the full particulars regarding each occurrence.

WASHINGTON METROPOLITAN AREA TRANSIT AUTHORITY

SUPPLY AND SERVICE CONTRACT

IFB-FQ12235/CPR

11. Financial resources available as working capital for the Contract:
 - a. Cash on hand \$ _____
 - b. Source of credit: _____
12. Attach as SCHEDULE FIVE financial statements and letters from banks regarding credit as required by the Pre-Award Information article.
13. What percentage of the work (contract amount) do you intend performing with your own personnel? _____%
14. Attach as SCHEDULE 15a list of all principal subcontractors and the percentage and character of work (contract amount) which each will perform. Principal items of work shall include, but not be limited to, those items listed in the Pre-Award Information article of the Invitation for Bid.
15. If the Contractor or subcontractor is a joint venture, submit PRE-AWARD EVALUATION DATA form for each member of the joint venture.

The information is confidential and will not be divulged to any unauthorized personnel.

The undersigned certifies to the accuracy of all information.

COMPANY: _____

SIGNATURE: _____

TITLE: _____

DATED: _____

LOCATION: _____

SECTION 1

GENERAL PROVISIONS

**SUPPLY AND SERVICE CONTRACT
GENERAL PROVISIONS**

1. DEFINITIONS

As used throughout this Contract, the following terms shall have the meanings set forth below:

- (a) "Authority" means the Washington Metropolitan Area Transit Authority created effective February 20, 1967, by Interstate Compact by and between Maryland, Virginia and the District of Columbia, pursuant to Public Law 89-774, approved November 6, 1966.
- (b) "Contracting Officer" means the person executing this Contract on behalf of the Authority and his or her successor. The term includes, except as otherwise provided in this Contract, the authorized representative of a Contracting Officer acting within the limits of his authority.
- (c) "Subcontract" means, except as otherwise provided in this Contract, a contract or contractual action entered into by a prime contractor or subcontractor for the purpose of obtaining supplies, materials, equipment, or services under a prime contract. Subcontracts include purchase orders under this Contract, as well as changes and modifications to purchase orders.
- (d) Wherever in the scope of the work the words directed, ordered, designated, prescribed or words of like import are used, it shall be understood that the direction, requirement, order, designation or prescription of the Contracting Officer is intended and similarly the words approved, acceptable, satisfactory or words of like import shall mean approved by, or acceptable to, or satisfactory to the Contracting Officer, unless otherwise expressly stated.
- (e) "Contractor" means the party (i.e., individual person or legal entity) that enters into a contract with the Authority to provide supplies or perform services to fulfill Authority requirements. With respect to subcontracting, "prime contractor" means "contractor."
- (f) "Services" means the performance of work by an individual person or legal entity under Contract with the Authority. Examples of services: maintenance, overhaul, repair, servicing, rehabilitation, salvage, modernization, or modification of supplies, systems, or equipment; routine recurring maintenance of real property; housekeeping; advisory and assistance; operation of authority-owned equipment, facilities, and systems; communication services; Architect-Engineering services; and transportation and related services.
- (g) "FTA" means the U.S. Department of Transportation, Federal Transit Administration.

2. ACCOUNTING AND RECORD KEEPING

- (a) Applicability. This clause shall become effective for and shall apply to any adjustment in the price of this Contract initiated by the Contractor or the Authority. However, where the original amount of this Contract is less than \$1,000,000, paragraph (c) of this clause does not apply unless the adjustment is expected to exceed \$50,000.
- (b) Forward Priced Adjustments. Unless expressly waived in writing in advance by the Contracting Officer, the Contractor shall furnish to the Contracting Officer a cost

WASHINGTON METROPOLITAN AREA TRANSIT AUTHORITY

SUPPLY AND SERVICE CONTRACT

IFB-FQ12235/CPR

proposal in advance of performance of any work for which a price adjustment is requested under this Contract. The Contractor shall originate such records as are necessary to substantiate all elements of the pricing proposal, current to the date of agreement on the pricing adjustment. Such records supporting the costs of each pricing adjustment request shall be specifically segregated and identified in the Contractor's accounting system as being applicable to the pricing adjustment request.

- (c) Post Pricing Adjustments. In addition to the records required to be originated under paragraph (b) above, in the event pricing of an adjustment under this Contract is not agreed upon between the Contractor and the Contracting Officer prior to the commencement of work for which the pricing adjustment is requested, the Contractor and any subcontractor engaged in work for which the pricing adjustment is requested, shall maintain accounts and original cost records specifically segregated and identified by job order or other appropriate accounting procedures approved by the Contracting Officer of all incurred segregable costs related to the work for which the pricing adjustment is requested. The Contractor shall maintain accounts and records which segregate and account for the costs of all work associated with that part of the project for which the pricing adjustment is requested and shall allocate the costs so accumulated between: (1) work required under the base Contract; (2) work requested to be reimbursed under the pricing adjustment; and (3) other claim, including but not limited to, changes, differing site conditions, and the like. The accounts and records so established shall accumulate such costs under logical costs groups, such as material, labor, equipment, subcontracts, field overhead and the like. The Contractor shall record these costs on a form approved by the Contracting Officer.

- (d) Availability. The accounts, records and costs information required to be originated under b. and c. above together with all other accounts, records and costs information related to this Contract, shall be maintained and made available by the Contractor and subcontractor(s):
 - (1) At the office of the Contractor or subcontractor(s) at all reasonable times for inspection, audit, reproduction or such other purposes as may be required by the Contracting Officer or by anyone authorized access to the records by the Contracting Officer or pursuant to any other provisions of this Contract; and
 - (2) Until the expiration of three years from the date of final payment under this Contract or such lesser time as is specified in Subpart 4.7 of the Federal Acquisition Regulations and for such longer period, if any, as is required by applicable statute, or by other clauses of this contract, or by paragraphs (i) and (ii) below:
 - (i) If the Contract is completely or partially terminated, for a period of three (3) years from either the date of any resulting final settlement or the date of final payment whichever is the greater period; and
 - (ii) If a pricing adjustment is involved in any appeal under the Disputes clause Article of this Contract or in any litigation related to this Contract, for a period of one (1) year following the final disposition of the appeal or litigation.

- (e) Access to Records. When asserting a claim involving a potential price adjustment under any provisions of this Contract, the Contractor shall grant the Authority access to

WASHINGTON METROPOLITAN AREA TRANSIT AUTHORITY

SUPPLY AND SERVICE CONTRACT

IFB-FQ12235/CPR

review and ascertain the validity of the accounting records being maintained for segregation of costs, including base cost records, and to audit such costs as are deemed appropriate by the Contracting Officer. No payment shall be made to the Contractor on its claim until such records are made available and access is permitted.

- (f) Limitation on Pricing Adjustment. In the event the Contractor or any subcontractor fails to originate or to maintain, or to make available any accounts or records required under this or any other clause of the Contract, the Contracting Officer may, at the Contracting Officer's discretion, determine the reasonableness of the direct cost of the work for which records are not available, and add a single mark-up for indirect expenses not to exceed ten percent (10%) of the direct costs based on:
- (1) An audit of any existing books and records of the Contractor or subcontractor; or
 - (2) An Authority estimate adopted by the Contracting Officer; or
 - (3) A combination of (1) and (2);

The Contractor and subcontractors shall not be allowed any profit on the work which such records are not available.

- (g) Flow-down clause. The Contractor shall insert a clause containing all the provisions of this clause in all subcontracts issued under this Contract, modified as necessary, for proper identification of the contracting parties and the Contracting Officer under this Contract.

3. ASSIGNMENT

- (a) Except as otherwise provided in this provision, the Contractor shall not transfer any of its rights and obligations under this Contract to third parties without the prior consent of the Authority. The Authority may recognize a third party as successor in interest to the Contract in the event of a transfer of all or substantially all of the assets of the Contractor, a Division of the Contractor involved in the performance of the Contract, or a Parent company providing a performance guarantee under this Contract, (i.e., sales of assets; transfer of assets pursuant to merger or consolidation; or incorporation of a proprietorship or partnership). Such recognition of the transfer shall be within the discretion of the Contracting Officer after review of the facts and circumstances surrounding each request. At the discretion of the Contracting Officer, the Contracting Officer may conduct an evaluation of the successor party's capability to perform the Contract in the same manner and to the same extent the Contracting Officer was empowered to conduct a responsibility determination as part of the original solicitation for this Contract. Should the Contracting Officer, for any reason, not recognize such a successor in interest, it may terminate this Contract for the convenience of the Authority.
- (b) For claims for monies due, or to become due the Contractor from the Authority under this Contract may be assigned to a bank, trust company, or other financing institution, including any Federal lending agency, and may thereafter be further assigned and reassigned to any institution, upon written notice of such assignment to the Authority. Any such assignment or reassignment shall cover all amounts payable under this Contract and not already paid and shall not be made to more than one party, except

SUPPLY AND SERVICE CONTRACT

IFB-FQ12235/CPR

that any such assignment or reassignment may be made to one party as agent or trustee for two or more parties participating in such financing. It is the Authority's intent to recognize assignments only to bona fide lending institutions; therefore, assignment to any private corporation, business or individual which does not qualify as such is specifically prohibited.

- (c) Any attempt to transfer by assignment not authorized by this provision shall constitute a breach of the Contract and the Authority may for such cause, terminate the Contract with the DEFAULT provision of these General Provisions, and the Contractor shall be liable to the Authority under the DEFAULT provision.

4. AUDIT AND RETENTION OF RECORDS

- (a) As used in this clause, "records" includes books, documents, accounting procedures and practices, and other data, regardless of type and regardless of whether such items are in written form, in the form of computer data, or in any other form.
- (b) Authorized persons. The Contracting Officer and his representatives, including representatives of the Authority's governing jurisdictions and any other federal, state, or local entity providing funding for this Contract and the Comptroller General of the United States, shall have access and inspection rights described in this clause.
- (c) Examination of costs. If this is a cost-reimbursement, incentive, time-and-materials, labor-hour, or price redeterminable contract, or any combination of these, the Contractor shall maintain and the Contracting Officer, or an authorized representative of the Contracting Officer, shall have the right to examine and audit all records and other evidence sufficient to reflect properly all costs claimed to have been incurred or anticipated to be incurred directly or indirectly in performance of this contract. This right of examination shall include inspection at all reasonable times of the Contractor's plants, or parts of them, engaged in performing this contract.
- (d) Cost or pricing data. If the Contractor has been required to submit cost or pricing data in connection with any pricing action relating to this contract, the Contracting Officer, or an authorized representative of the Contracting Officer, in order to evaluate the accuracy, completeness, and currency of the cost or pricing data, shall have the right to examine and audit all of the Contractor's records, including computations and projections, related to: (1) the bid for the contract, subcontract, or modification; (2) the discussions conducted on the bid(s), including those related to negotiating; (3) pricing of the contract, subcontract or modification; or (4) performance of the contract, subcontract or modification.
- (e) Reports. If the Contractor is required to furnish cost, funding or performance reports, the Contracting Officer or an authorized representative of the Contracting Officer shall have the right to examine and audit the supporting records and materials, for the purpose of evaluating the effectiveness of the Contractor's policies and procedures to produce data compatible with the objectives of these reports; and the data reported.
- (f) Availability. The Contractor shall make available at its offices at all reasonable times the records, materials, and other evidence described above, for examination, audit or reproduction, until three (3) years after final payment under this contract or for any shorter period specified in Subpart 4.7, Contractor Records Retention, of the Federal

WASHINGTON METROPOLITAN AREA TRANSIT AUTHORITY

SUPPLY AND SERVICE CONTRACT

IFB-FQ12235/CPR

Acquisition Regulation (FAR), or for any longer period required by statute or by other clauses of this contract. In addition—

- (1) If this contract is completely or partially terminated, the Contractor shall make available the records relating to the work terminated until three (3) years after any resulting final termination settlement; and
 - (2) The Contractor shall make available records relating to appeals under the Disputes clause or to litigation or the settlement of claims arising under or relating to this contract until such appeals, litigation or claims are fully resolved.
- (g) Subcontracts. The Contractor shall insert a clause containing all the terms of this clause, including this paragraph (g), in all subcontracts under this Contract that exceed the simplified acquisition threshold (currently \$100,000) and –
- (1) That is cost reimbursable, incentive, time-and-material, labor-hour, or price redeterminable type or any combination of these;
 - (2) For which cost or pricing data are required; or
 - (3) That requires the contractor to submit reports as discussed in paragraph (e) of this clause.

5. AUTHORITY DELAY OF WORK

- (a) If the performance of all or any part of the work is delayed or interrupted (1) by an act of the Contracting Officer in the administration of this Contract, which act is not expressly or impliedly authorized by this Contract, or (2) by a failure of the Contracting Officer to act within the time specified, an adjustment (excluding profit) shall be made for any increase in the cost of performance of this Contract caused by such delay or interruption and the contract modified in writing accordingly. Adjustment shall be made also in the delivery or performance dates and any other contractual provision affected by such delay or interruption. However, no adjustment shall be made under this clause for any delay or interruption to the extent that performance would have been delayed or interrupted by any other cause, including the fault or negligence of the Contractor; or for which an adjustment is provided or excluded under any other provision of this Contract.
- (b) A claim under this clause shall not be allowed:
- (1) for any costs incurred more than 20 days before the Contractor shall have notified the Contracting Officer in writing of the act or failure to act involved; and
 - (2) Unless the claim, in an amount stated, is asserted in writing as soon as practicable after the termination of the delay or interruption, but not later than the day of final payment under the Contract.

6. CERTIFICATE OF CURRENT COST OR PRICING DATA

The Contractor shall provide a Certificate of Current Cost or Pricing Data as required in Subpart 15.406 of the Federal Acquisition Regulations (48 CFR 15.406) in support of any

WASHINGTON METROPOLITAN AREA TRANSIT AUTHORITY

SUPPLY AND SERVICE CONTRACT

IFB-FQ12235/CPR

negotiated contract modification, for which the aggregate of the increase and decreases in cost are expected to exceed \$100,000. The Contractor may be requested, at the discretion of the Contracting Officer, to provide cost or pricing data and an attendant certificate of current cost or pricing data, for modifications on which cost are \$100,000 or less.

7. CHANGES

- (a) The Contracting Officer may at any time, by a written order, and without notice to the sureties, if any, make changes, within the general scope of this Contract, in any one or more of the following:
 - (1) Description of services to be performed;
 - (2) Time of performance (i.e., hours of the day, days of the week, etc.); or
 - (3) Place of performance of the services.
- (b) If any such change causes an increase or decrease in the cost of, or the time required for, the performance of any part of the work under this Contract, whether changed or not changed by the order, the Contracting Officer shall make an equitable adjustment in the Contract price, the delivery schedule, or both, and shall modify the Contract.
- (c) The Contractor must assert its right to an adjustment under this clause article within 30 days from the date of receipt of the written order. Any such adjustment to the contract price must be agreed upon, prior to final payment of the contract price.
- (d) If the Contractor's bid includes the cost of property made obsolete or excess by the change, the Contracting Officer shall have the right to prescribe the manner of the disposition of the property.
- (e) Failure to agree to any adjustment shall be a dispute under the Disputes clause. However, nothing in this clause shall excuse the Contractor from proceeding with the contract as changed.
- (f) Notwithstanding any other provision of this Contract, the Contractor shall promptly notify the Contracting Officer of matters which will result in either an increase or decrease in the Contract price and shall take action with respect thereto as directed by the Contracting Officer.

8. NONDISCRIMINATION ASSURANCE

- (a) Nondiscrimination Assurance: In accordance with Title VI of the Civil Rights Act, as amended, 42 U.S.C. §2000d, section 303 of the Age Discrimination Act of 1975, as amended, 42 U.S.C. §6102, section 202 of the American with Disabilities Act of 1990, 42 U.S.C. §12132, and Federal transit law at 49 U.S.C. §5332, the contractor agrees that it will not discriminate against any employee or applicant for employment because of race, color, creed, national origin, sex, age, or disability. In addition, the Contractor agrees to comply with applicable Federal implementing regulations and other implementing regulations that FTA may issue.
- (b) Equal Employment Opportunity: The following equal employment opportunity requirements apply to this contract.

- (1) Race, Color, Creed, National Origin, Sex: In accordance with Title VII of the Civil Rights Act, as amended, 42 U.S.C. §2000e, and Federal transit laws at 49 U.S.C. §5332, the Contractor agrees to comply with all applicable equal opportunity requirements of the U. S. Department of Labor (U.S. DOL) regulations, "Office of Federal Contract Compliance Programs, Equal Employment Opportunity, Department of Labor, " 41 C.F.R. Parts 60 et seq., (which implement Executive Order No. 11246, "Equal Employment Opportunity," as amended by Executive Order No. 11375, "Amending Executive Order 11246 Relating to Equal Employment Opportunity," 42 U.S.C. 2000e note), and with any applicable Federal statutes, executive orders, regulations, and Federal policies that may in the future affect construction activities undertaken in the course of the Contract. The Contractor agrees to take affirmative action to ensure that applicants are employed, and that employees are treated during employment without regard to their race, color, creed, national origin, sex or age. Such action shall include, but not be limited to, the following: employment, upgrading, demotion or transfer, recruitment or recruitment advertising, layoff or termination; rates of pay or other forms of compensation; and selection for training, including apprenticeship. In addition, the Contractor agrees to comply with any implementing requirements FTA may issue.
 - (2) Age: In accordance with Section 4 of the Age Discrimination in Employment Act of 1967, as amended, 29 U.S.C. §623 and Federal transit law at 49 U.S.C. §5332, the Contractor agrees to refrain from discrimination against present and prospective employees for reason of age. In addition, the Contractor agrees to comply with any implementing requirements FTA may issue.
 - (3) Disabilities: In accordance with section 102 of the Americans with Disabilities Act, as amended, 42 U.S.C. §12112, the Contractor agrees that it will comply with the requirements of U. S. Equal Employment Opportunity Commission, "Regulations to Implement the Equal Employment Provisions of the Americans with Disabilities Act," 29 C.F.R. Part 1630, pertaining to employment of persons with disabilities. In addition, the Contractor agrees to comply with any implementing requirements FTA may issue.
- (c) The Contractor also agrees to include all of these requirements in each subcontract financed in whole or in part with Federal assistance provided by FTA, modified only if necessary to identify the affected parties.

9. CONTRACT WORK HOURS AND SAFETY STANDARDS ACT-OVERTIME COMPENSATION

This Contract, to the extent that it is of a character specified in the Contract Work Hours and Safety Standards Act (40 U.S.C. 327-333), is subject to the following provisions and to all other applicable provisions and exceptions of such Act and the regulations of the Secretary of Labor thereunder.

- (a) Overtime requirements. No Contractor or subcontractor contracting for any part of the contract work which may require or involve the employment of laborers, mechanics, apprentices, trainees, watchmen, and guards shall require or permit any laborer, mechanic, apprentice, trainee, watchman, or guard in any workweek in which he is

WASHINGTON METROPOLITAN AREA TRANSIT AUTHORITY

SUPPLY AND SERVICE CONTRACT

IFB-FQ12235/CPR

employed on such work to work in excess of 40 hours in such work week on work subject to the provisions of the Contract Work Hours and Safety Standards Act unless such laborer, mechanic, apprentice, trainee, watchman, or guard receives compensation at a rate not less than one and one-half times his basic rate of pay for all such hours worked in excess of 40 hours in such work week.

- (b) Violation. Liability for Unpaid Wages - Liquidated damages. In the event of any violation of the provisions of paragraph (a) the Contractor and any subcontractor responsible therefore shall be liable to any affected employee for his unpaid wages. In addition, such Contractor and subcontractor shall be liable to the Authority for liquidated damages. Such liquidated damages shall be computed with respect to each individual laborer, mechanic, apprentice, trainee, watchman or guard employed in violation of the provision of paragraph (a) in the sum of \$10 for each calendar day on which such employee was required or permitted to be employed on such work in excess of his standard work week of 40 hours without payment of the overtime wages required by paragraph (a).
- (c) Withholding for unpaid wages and liquidated damages. The Contracting Officer may withhold from the Authority Contractor, from any monies payable on account of work performed by the Contractor or subcontractor, such sums as may be administratively determined to be necessary to satisfy any liabilities of such Contractor or subcontractor for unpaid wages and liquidated damages as provided in the provisions of paragraph (b).
- (d) Subcontracts. The Contractor shall insert paragraphs (a) through (d) of this clause in all subcontracts and shall require their inclusion in all subcontracts of any tier.
- (e) Records. The Contractor shall maintain payroll records containing the information specified in 29 CFR 516.2(a). Such records shall be preserved for three (3) years from the completion of this Contract.

10. CONVICT LABOR

- (a) Except as provided in paragraph (b) of this clause, the Contractor shall not employ in the performance of this contract any person undergoing a sentence of imprisonment imposed by any court of a State, the District of Columbia, Puerto Rico, the Northern Mariana Islands, American Samoa, Guam or the U.S. Virgin Islands.
- (b) The Contractor is not prohibited from employing persons:
 - (1) On parole or probation to work at paid employment during the term of their sentence;
 - (2) Who have been pardoned or who have served their terms; or
 - (3) Confined for violation of the laws of the States, the District of Columbia, Puerto Rico, the Northern Mariana Islands, American Samoa, Guam, or the U.S. Virgin Islands who are authorized to work at paid employment in the community under the laws of such jurisdiction, if—
 - (i) The worker is paid or is in an approved work or training program on a voluntary basis;

WASHINGTON METROPOLITAN AREA TRANSIT AUTHORITY

SUPPLY AND SERVICE CONTRACT

IFB-FQ12235/CPR

- (ii) Representatives of local union central bodies or similar labor union organizations have been consulted;
- (iii) Such paid employment will not result in the displacement of employed workers, or be applied in skills, crafts, or trades in which there is a surplus of available gainful labor in the locality, or impair existing contracts or services;
- (iv) The rates of pay and other conditions of employment will not be less than those paid or provided for work of a similar nature in the locality in which the work is being performed; and
- (v) The Attorney General of the United States has certified that the work-release laws or regulations of the jurisdiction involved are in conformity with the requirements of Executive Order 11755, as amended by Executive Orders 12608 and 12943.

11. CORRECTION OF DEFICIENCIES

(a) Definitions, as used in this provision:

- (1) "Deficiency" means any condition or characteristics in any supplies (which term shall include related technical data) or services furnished hereunder, which is not in compliance with the requirements of this Contract.
- (2) "Correction" means any and all actions necessary to eliminate any and all deficiencies.
- (3) "Supplies" mean the end item(s) furnished by the Contractor and related services required under this Contract.

(b) General:

- (1) The rights and remedies of the Authority provided in this provision:
 - (i) Shall not be affected in any way by any other provision(s) under this Contract concerning the conclusiveness of inspection and acceptance; and
 - (ii) Are in addition to and do not limit any rights afforded to the Authority by any other provision article of this Contract.
- (2) This provision shall apply only to those deficiencies discovered by either the Authority or the Contractor within one year after acceptance.
- (3) The Contractor shall not be responsible under this provision for the correction of deficiencies in Authority furnished property, except for deficiencies in installation, unless the Contractor performs or is obligated to perform any modifications or other work on such property. In that event, the Contractor shall be responsible for correction of deficiencies to the extent of such modifications or other work.
- (4) The Contractor shall not be responsible under this provision article for the correction of deficiencies caused by the Authority.

WASHINGTON METROPOLITAN AREA TRANSIT AUTHORITY

SUPPLY AND SERVICE CONTRACT

IFB-FQ12235/CPR

- (c) Deficiencies in accepted supplies or services:
- (1) Notice to Contractor - Recommendation for Correction. If the Contracting Officer determines that a deficiency exists in any of the supplies or services accepted by the Authority under this Contract, the Contracting Officer shall promptly notify the Contractor of the deficiency, in writing, within 30 days. Upon timely notification of the existence of such a deficiency, or if the Contractor independently discovers a deficiency in accepted supplies or services, the Contractor shall promptly submit to the Contracting Officer its recommendation for corrective actions, together with supporting information in sufficient detail for the Contracting Officer to determine what corrective action, if any, shall be undertaken.
 - (2) Direction to Contractor concerning correction of deficiencies. Within 30 days after receipt of the Contractor's recommendations for corrective action and adequate supporting information, the Contracting Officer, at his sole discretion, shall give the Contractor written notice not to correct any deficiency, or to correct or partially correct any deficiency within a reasonable time and at a specified location.
 - (3) Correction of deficiencies by Contractor. The Contractor shall promptly comply with any timely written direction by the Contracting Officer to correct or partially correct a deficiency, at no additional cost to the Authority. The Contractor shall also prepare and furnish to the Authority data and reports applicable to any correction required under this provision (including revision and updating of all other affected data called for under this Contract) at no additional cost to the Authority.
 - (4) Bid for correction. In the event of timely notice of a decision not to correct or only to partially correct, the Contractor shall promptly submit a technical and cost proposal for compensation to the Authority for the diminished value received. If the Contract has not been completed, this may be accomplished as a scope and price modification to the Contract.
- (d) Deficiencies in supplies or services not yet accepted. If the Contractor becomes aware at any time before acceptance by the Authority (whether before or after tender to the Authority) that a deficiency exists in any supplies or services, it shall promptly correct the deficiency. If in the Contractor's judgment such correction is not feasible or in the Authority's best interest, it shall promptly notify the Contracting Officer, in writing, of the deficiency, the reasons for its recommendation not to correct the deficiency, and provide a detailed technical and cost proposal for recommended alternatives.
- (e) No extension in time for performance - No increase in Contract price. In no event shall the Authority be responsible for extension or delays in the schedule deliveries or periods of performance under this Contract as a result of the Contractor's obligations to correct deficiencies, nor shall there be any adjustment of the delivery schedule or period of performance as a result of such correction of deficiencies, except as may be agreed to by the Authority in a contract modification with adequate consideration. This provision shall not be construed as obligating the Authority to increase the Contract price of this Contract.

WASHINGTON METROPOLITAN AREA TRANSIT AUTHORITY

SUPPLY AND SERVICE CONTRACT

IFB-FQ12235/CPR

- (f) Transportation charges. If the agreed upon correction requires the Authority to ship supplies or other items to the Contractor, the Contractor shall be liable for determining the method of shipment and bearing the cost and risk of loss for such supplies or other items while in transit, and until they are redelivered to the Authority. For the purpose of this provision, the terms "supplies" and "shipment" include both tangible and intangible (e.g., electronic) items and methods.
- (g) Failure to correct. If the Contractor fails or refuses to comply with any term of this provision, or fails to exercise its professional judgment in good faith regarding the identification or correction of any deficiency, the Contracting Officer may proceed in accordance with the Termination for Default provision of this contract. In such event, the Contractor shall be liable for all costs incurred by the Authority in connection with the Termination for Default provision, including but not by way of limitation, the employment of consultants or other contractors to identify the deficiency, to make recommendations regarding methods of correcting the deficiency, the actual correction of the deficiency, and risk of the continued use of the defective supplies, methods of achieving the end purpose of the supplies or other items until the deficiency is corrected, and the estimated cost thereof.
- (h) Correction of deficient replacements and re-performances. The corrected or replaced supplies and any services re-performed pursuant to this provision shall also be subject to all the provisions of the clause to the same extent as supplies or services initially accepted.
- (i) Disassembly/reassembly expense. The Contractor shall be liable for the reasonable cost of any disassembly, reassembly, repair or replacement of Authority property required to implement the correction(s) required in accordance with this provision.

12. COST OR PRICING DATA

- (a) As part of its pricing proposal for any modification to this Contract requiring a price adjustment involving an aggregate increase or decrease in excess of \$100,000 to the Contract price, the Contractor shall submit to the Contracting Officer, either actually or by specific identification in writing, cost or pricing data under the conditions described in this paragraph and certify that, to the best of its knowledge and belief, the cost or pricing data submitted is accurate, complete and current as of the date of the bid. The Contractor, at the discretion of the Contracting Officer, may be required to submit cost or pricing data for price adjustments less than \$100,000.
- (b) The submittal of certified cost or pricing data shall not be required if the price adjustment is based on adequate price competition, established catalog or market prices of commercial items sold in substantial quantities to the general public, or prices set by law or regulation. The Contractor agrees that the terms adequate price competition and established catalog or market prices of commercial items sold in substantial quantities to the general public shall be determined by the Contracting Officer in accordance with the guidelines as set forth in Subpart 15.4 of the Federal Acquisition Regulations (48 CFR 15.4).
- (c) Cost or pricing data consists of all facts existing up to the time of agreement on price which prudent buyers and sellers would reasonably expect to have a significant effect on the price negotiations for the modification. The definition of cost or pricing data embraces more than historical accounting data; it also includes where applicable, such

factors as subcontractor, supplier and vendor quotations, non-recurring costs, changes in construction methods or contract performance, unit cost trends such as those associated with labor efficiency and any management decisions which could reasonably be expected to have a significant bearing on costs under the proposed modification and the Contract work. Cost or pricing data consists of all facts which can reasonably be expected to contribute to sound estimates of future costs as well as to the validity of costs already incurred. Cost or pricing data, being factual, is that type of information which can be verified. Because the certificate pertains to cost or pricing data, it does not make representations as to the accuracy of the Contractor's judgment on the estimated portion of future costs or projections. The certificate does, however, apply to the data upon which the Contractor's judgment is based.

13. COVENANT AGAINST CONTINGENT FEES

The Contractor warrants that no person or selling agency has been employed or retained to solicit or secure this Contract upon an agreement or understanding for a commission, percentage, brokerage or contingent fee, excepting bona fide employees or bona fide established commercial or selling agencies maintained by the Contractor for the purpose of securing business. For breach or violation of this warranty, the Authority shall have the right to annul this Contract without liability or in its discretion, to deduct from the Contract price or consideration, or otherwise recover, the full amount of such commission, percentage, brokerage, or contingent fee.

14. DEFAULT

(a)(1) The Authority may, subject to paragraphs (c) and (d) of this clause, by written notice of default to the Contractor, terminate this Contract in whole or part if the Contractor fails to:

- (i) Deliver the supplies or to perform the services within the time specified in the contract, herein or any extension thereof;
- (ii) Make progress, so as to endanger performance of the contract; or
- (iii) Perform any of the other provisions of this contract.

(2) The Authority's right to terminate this contract under paragraphs (a)(1)(ii) and (a)(1)(iii) above, may be exercised if the contractor does not cure such failures within 10 days (or more if authorized by the Contracting Officer) after receipt of notice from the Contracting Officer specifying the failure.

(b) If the Authority terminates this Contract in whole or in part, it may procure, under the terms and in the manner as the Contracting Officer considers appropriate, supplies or services similar to those terminated in this contract, and the Contractor will be liable to the Authority for any excess costs for those supplies or services. However, the Contractor shall continue the work not terminated.

(c) Except for defaults of subcontractors at any tier, the Contractor shall not be liable for any excess costs if the failure to perform the Contract arises from causes beyond the control and without the fault or negligence of the Contractor. Examples of such causes include (1) acts of God or of the public enemy; (2) acts of the Government in its sovereign capacity or the Authority in its contractual capacity; (3) fires; (4) floods; (5)

WASHINGTON METROPOLITAN AREA TRANSIT AUTHORITY

SUPPLY AND SERVICE CONTRACT

IFB-FQ12235/CPR

epidemics; (6) quarantine restrictions; (7) strikes; (8) freight embargoes; and (9) unusually severe weather. In each instance the failure to perform must be beyond the control and without the fault or negligence of the Contractor.

- (d) If the failure to perform is caused by the default of a subcontractor at any tier, and if the cause of the default is beyond the control of both the Contractor and subcontractor, and without the fault or negligence of either, the Contractor shall not be liable for any excess costs for failure to perform, unless the subcontracted supplies or services were obtainable from other sources in sufficient time for the Contractor to meet the required delivery schedule.
- (e) If this Contract is terminated for default, the Authority may require the Contractor to transfer title and deliver to the Authority, as directed by the Contracting Officer (1) any completed supplies, and (2) partially completed supplies and materials, parts, tools, dies, jigs, fixtures, plans, drawings, information (including data and intellectual property) and contract rights that the Contractor has specifically produced or acquired for the terminated portion of this contract. Upon direction of the Contracting Officer, the Contractor shall also protect and preserve property in its possession in which the Authority has an interest.
- (f) The Authority shall pay contract price for completed supplies delivered and accepted. The Contractor and Contracting Officer shall agree on the amount of payment for items identified in paragraph (e) above that were delivered and accepted by the Authority and for the protection and preservation of property. Failure to agree shall be a dispute under the DISPUTES clause of this Contract. The Authority may withhold from these amounts any sum the Contracting Officer determines to be necessary to protect the Authority against loss because of outstanding liens or claims of former lien holders.
- (g) If, after termination, it is determined that the Contractor was not in default or that the default was excusable, the rights and obligations of the parties shall be the same as if the notice of termination had been issued for the convenience of the Authority.
- (h) The rights and remedies of the Authority in this clause are in addition to any other rights and remedies provided by law or under this Contract.

15. DISPUTES

- (a) Except as otherwise provided in this Contract, any dispute concerning a question of fact arising under or related to this Contract which is not disposed of by agreement shall be decided by the Contracting Officer, who shall reduce his/her decision to writing and mail or otherwise furnish a copy thereof to the Contractor. The decision of the Contracting Officer shall be final and conclusive unless, within thirty (30) calendar days from the date of receipt of such copy, the Contractor mails or otherwise furnishes to the Contracting Officer a written notice of appeal addressed to the Authority Board of Directors. Such notice would indicate that an appeal is intended and should reference the decision and contract number. The decision of the Board of Directors or its duly authorized representative for the determination of such appeals shall be final and conclusive unless in proceedings initiated by either party for review of such decision in a court of competent jurisdiction, the court determines the decision to have been fraudulent, or capricious, or arbitrary, or so grossly erroneous as necessarily to imply bad faith, or is not supported by substantial evidence. In connection with any appeal proceeding under this clause, the Contractor, or the Authority, as the case may be,

WASHINGTON METROPOLITAN AREA TRANSIT AUTHORITY

SUPPLY AND SERVICE CONTRACT

IFB-FQ12235/CPR

shall be afforded an opportunity to be heard and offer evidence in support of its appeal. Pending final decision of a dispute hereunder, the Contractor shall proceed diligently with the performance of the Contract and in accordance with the Contracting Officer's decision. The Armed Services Board of Contract Appeals is the authorized representative of the Board of Directors for final decisions on an appeal.

- (b) This DISPUTES clause does not preclude consideration of question of law in connection with decisions provided for in Section a. above. Nothing in the Contract, however, shall be construed as making final the decisions of the Board of Directors or its representative on a question of law.

16. EMPLOYMENT RESTRICTION WARRANTY

- (a) The Contractor warrants that it will not offer employment to any officer or employee of the Washington Metropolitan Area Transit Authority (Authority) who has been involved, directly or indirectly, in any matter of financial interest to the Contractor until at least one (1) year after the officer or employee has ceased involvement in or responsibility for the matter.
- (b) The Contractor further warrants that it will not employ any Authority officer or employee who has had direct responsibility for any matter of financial interest to the Contractor within the year prior to the retirement or termination of the officer or employee until at least one (1) full year after such officer or employee has left the employment of the Authority.
- (c) The one (1) year requirement described in this provision may be waived at the discretion of the Contracting Officer if the Authority employee or former employee has been subject to a Reduction in Force; in such case, the Contracting Officer will provide the Contractor with a letter to that effect.
- (d) If a waiver is granted, or if a former employee of the Authority is eventually hired, the Contractor shall be responsible for ensuring that the former employee is not directly involved in negotiating or otherwise dealing with Authority on any particular matter over which such employee had responsibility during his or her period of employment at Authority.
- (e) Should the Contractor fail to comply with paragraphs (a), (b) or (d) above, the Contracting Officer shall have the right to withhold payment under this Contract in an amount not to exceed 2% of the total Contract amount as liquidated damages to the Authority, such withholding to be in addition to any other withholding under this Contract. Further, the Contracting Officer shall consider such violation in evaluating the Contractor's responsibility in connection with award of any future Authority Contract.

17. EXTRAS (SUPPLIES)

Except as otherwise provided in this Contract, no payment for extras shall be made unless such extras and the prices therefore have been authorized in writing in advance by the Contracting Officer.

18. FEDERAL, STATE, AND LOCAL TAXES

- (a) Except as may be otherwise provided in this Contract, the Contract price includes all applicable Federal, State and Local taxes and duties.
- (b) Nevertheless, with respect to any Federal excise tax or duty on the transactions or property covered by this Contract, if a statute, court decision, written ruling or regulation takes effect after the Contract date, and:
 - (1) Results in the Contractor being required to pay or bear the burden of any such Federal excise tax or duty or increase in the rate thereof which would not otherwise have been payable on such transactions or property, the Contract price shall be increased by the amount of such tax or duty or rate increase, provided the Contractor warrants in writing that no amount for such newly imposed Federal excise tax or duty or rate increase was included in the Contract price as a contingency reserve or otherwise; or
 - (2) Results in the Contractor not being required to pay or bear the burden of, or in his obtaining a refund or drawback of, any such Federal excise tax or duty which would otherwise have been payable on such transactions or property or which was the basis of an increase in the Contract price, the Contract price shall be decreased by the amount of the relief, refund, or drawback, or that amount shall be paid to the Authority, as directed by the Contracting Officer. The Contract price shall be similarly decreased if the Contractor, through his fault or negligence or his failure to follow instructions of the Contracting Officer, is required to pay or bear the burden of, or does not obtain a refund or drawback of, any such Federal excise tax or duty.
- (c) Paragraph (b) above shall not be applicable to social security taxes or to any other employment tax.
- (d) No adjustment of less than \$250 shall be made in the Contract price pursuant to paragraph (b) above.
- (e) As used in paragraph (b) above, the term "Contract date" means the date the contract was executed by the Authority. As to additional supplies or services procured by modification to this Contract, the term "Contract date" means the effective date of such modification.
- (f) Unless a reasonable basis to sustain an exemption does not exist, the Authority upon the request of the Contractor shall, without further liability, furnish evidence appropriate to establish exemption from any relevant Federal, State or Local tax; provided that evidence appropriate to establish exemption from any Federal excise tax or duty which may give rise to either an increase or decrease in the Contract price, will be furnished only at the discretion of the Authority.
- (g) The Contractor shall promptly notify the Contracting Officer of matters which will result in either an increase or decrease in the Contract price and shall take action with respect thereto as directed by the Contracting Officer.

19. GRATUITIES

- (a) In connection with performance of work required under this Contract, or any changes or modifications relative thereto, the giving of or offering to give gratuities (in the form of entertainment, gifts or otherwise) by the Contractor, or any agent, representative or other person deemed to be acting on behalf of the Contractor, or any supplier or subcontractor furnishing material to or performing work under this Contractor, or any agent, representative or other person deemed to be acting on behalf of such supplier or subcontractor, to any Director, Officer or employee of the Authority; or to any Director, Officer, employee or agent of any of the Authority's agents, consultants, representatives or other persons deemed to be acting for or on behalf of the Authority with a view toward securing a contract or securing favorable treatment with respect to the awarding or amending, or the making of any determinations with respect to the performing of such contract is expressly forbidden. The terms of this GRATUITIES clause shall be strictly construed and enforced in the event of violations hereto.
- (b) Reported instances of the giving or offering to give gratuities within the context of this GRATUITIES clause will be investigated by the Board of Directors or its duly authorized representative. A preliminary investigation will be made to determine whether there is probable cause to suspect that a violation of this clause has been committed. If such probable cause is found to exist, the Board of Directors, or its duly authorized representative, shall formally notify the suspected donor corporation or individual in writing of the particulars of the event; and provide such donor the opportunity to be heard on the matter. The aims of the investigations and hearing shall be to ensure due process and to preserve the best interests and rights of all parties by the full and fair disclosure of all relevant and material information. Accordingly, the Board of Directors, or its duly authorized representative, shall require production of all pertinent documents and records, and sworn testimony from witnesses. During the pendency of any investigation or hearing treating with a violation of this GRATUITIES clause, the Board of Directors, or its duly authorized representative may exercise its power granted by the Washington Metropolitan Area Transit Authority Compact, Public Law 774, 80 Star. 1324, Article V, General Powers, Subparagraph (k), by issuing subpoenas to compel the attendance of necessary witnesses, and to compel production of papers, records, accounts, ledgers and documents. The subpoenas shall be enforceable by order of an appropriate United States District Court. If, after notice and hearing, or notice of the opportunity to be heard, the Board of Directors, or its duly authorized representative, finds that a violation of this GRATUITIES clause has been committed, the Authority shall have the right to:
- (1) Require that the individual(s) giving or offering the gratuity be removed from further participation on any Authority projects, (be terminated);
 - (2) Deny the Contractor any G & A (general and administrative) mark-ups for all changes and/or modifications found to be tainted by the giving of or offering to give gratuities;
 - (3) Preclude the Contractor from bidding on, receiving or participating as joint venturer, subcontractor or otherwise in any Authority project for a period of five (5) years;

WASHINGTON METROPOLITAN AREA TRANSIT AUTHORITY

SUPPLY AND SERVICE CONTRACT

IFB-FQ12235/CPR

- (4) Have complete access to all the Contractor's financial books, records and accounts for the purpose of performing a comprehensive audit of the entire project.
- (5) In the event of repeated violations of this GRATUITIES clause or of gross or extreme conduct indicative of a corrupt intent to gain special advantage, by written notice to the Contractor, terminate the right of the Contractor to proceed under the Contract.
- (c) The existence of the facts upon which the Board of Directors, or its duly authorized representative, makes findings in connection with investigations and hearings in consonance herewith, shall be an issue and may be reviewed in any competent court.
- (d) In the event this Contract is terminated as provided in paragraph (b)(5) of this clause, the Authority shall be entitled:
 - (1) To pursue the same remedies against the Contractor as it could pursue in the event of a breach of the Contract by the Contractor; and
 - (2) As a penalty in addition to any other damages to which it may be entitled by law, to exemplary damages in any amount (as determined by the Board or its duly authorized representative) which shall be not less than three (3) nor more than ten (10) times the costs incurred by the Contractor in providing any such gratuities to any such officer or employee.
- (e) The rights and remedies of the Authority provided in this clause shall not be exclusive and are in addition to any other rights and remedies provided by law or under this Contract.

20. INSPECTION OF SERVICES

- (a) "Services" as used in this clause, includes services performed, workmanship, and material furnished or utilized in the performance of services.
- (b) The Contractor shall provide and maintain an inspection system acceptable to the Authority covering the services under this contract. Complete records of all inspection work performed by the Contractor shall be maintained and made available to the Authority during contract performance and for as long afterwards as the Contract requires.
- (c) The Authority has the right to inspect and test all services called for by this contract, to the extent practicable at all times and places during the term of the contract. The Authority shall perform inspection and tests in a manner that will not unduly delay the work.
- (d) If the Authority performs inspections or tests on the premises of the Contractor or a subcontractor, the Contractor shall furnish, and shall require subcontractors to furnish, at non-increase in contract price, all reasonable facilities and assistance for the safe and convenient performance of these duties.
- (e) If any of the services performed do not conform to contract requirements, the Authority may require the Contractor to perform the services again in conformity with contract

requirements, for no additional fee. When the defects in performance cannot be corrected by re-performance, the Authority may:

- (1) Require the Contractor to take necessary action to ensure that future performance conforms to contract requirements; or
 - (2) Reduce the contract price to reflect the reduced value of the services performed.
- (g) If the Contractor fails to promptly perform the services again or to take the necessary action to ensure future performance in conformity with contract requirements, the Authority may:
- (1) By contract or otherwise, perform the services and charge to the contractor any cost incurred by the Authority that is directly related to the performance of the service; or
 - (2) Terminate the contract for default.

21. INSPECTION OF SUPPLIES

- (a) "Supplies," as used in this clause, includes but is not limited to raw materials, components, intermediate assemblies, end products and lots of supplies.
- (b) The Contractor shall provide and maintain an inspection system acceptable to the Authority covering supplies under this contract and shall tender to the Authority for acceptance only supplies that have been inspected in accordance with the inspection system and have been found by the Contractor to be in conformity with contract requirements. As part of the system, the Contractor shall prepare records evidencing all inspections made under the system and the outcome. These records shall be kept complete and made available to the Authority during contract performance and for as long afterwards as the contract requires. The Authority may perform reviews and evaluations as reasonably necessary to ascertain compliance with this paragraph. These reviews and evaluations shall be conducted in a manner that will not unduly delay the contract work. The right of review, whether exercised or not, does not relieve the Contractor of the obligations under the contract.
- (c) The Authority has the right to inspect and test all supplies called for by the contract, to the extent practicable, at all places and times, including the period of manufacture, and in any event before acceptance. The Authority shall perform inspections and tests in a manner that will not unduly delay the work. The Authority assumes no contractual obligation to perform any inspection and test for the benefit of the Contractor unless specifically set forth elsewhere in this contract.
- (d) If the Authority performs inspection or test(s) on the premises of the Contractor or a subcontractor, the Contractor shall furnish, and shall require subcontractors to furnish, at no increase in contract price, all reasonable facilities and assistance for the safe and convenient performance of these duties. The Authority, except as otherwise provided in the contract, shall bear the expense of Authority inspections or tests made at other than the Contractor's or subcontractor's premises; provided, that in case of rejection, the Authority shall not be liable for any reduction in the value of inspection or test samples.

WASHINGTON METROPOLITAN AREA TRANSIT AUTHORITY

SUPPLY AND SERVICE CONTRACT

IFB-FQ12235/CPR

- (e) When supplies are not ready at the time specified by the Contractor for inspection or test, the Contracting Officer may charge to the Contractor the additional cost of inspection or test. The Contracting Officer may also charge the Contractor for any additional cost of inspection or test when prior rejection makes re-inspection or retest necessary.
- (f) The Authority has the right either to reject or to require correction of nonconforming supplies. Supplies are nonconforming when they are defective in material or workmanship or are otherwise not in conformity with contract requirements. The Authority may reject nonconforming supplies with or without disposition instructions.
- (g) The Contractor shall remove supplies rejected or required to be corrected. However, the Contracting Officer may require or permit correction in place, promptly after notice, by and at the expense of the Contractor. The Contractor shall not tender for acceptance corrected or rejected supplies without disclosing the former rejection or requirement for correction, and, when required, shall disclose the corrective action taken.
- (h) If the Contractor fails to promptly remove, replace, or correct rejected supplies that are required to be removed or to be replaced or corrected, the Authority may either: (1) by contract or otherwise, remove, replace, or correct the supplies and charge the cost to the Contractor; or (2) terminate the contract for default. Unless the Contractor replaces the supplies within the delivery schedule, the Contracting Officer may require their delivery and make an equitable price reduction. Failure to agree to a price reduction shall be a dispute.
- (i)
 - (1) If this contract provides for the performance of Authority quality assurance at source, and if requested by the Authority, the Contractor shall furnish advance notification of the time: (i) when Contractor inspection or tests will be performed in accordance with the terms and conditions of the contract; and (ii) when the supplies will be ready for Authority inspection.
 - (2) The Authority's request shall specify the period and method of the advance notification and the Authority representative to whom it shall be furnished. Requests shall not require more than two (2) workdays of advance notification if the Authority representative is in residence in the Contractor's plant, nor more than seven (7) workdays in other instances.
- (j) The Authority shall accept or reject supplies as promptly as practicable after delivery, unless otherwise provided in the contract. Authority failure to inspect and accept or reject the supplies shall not relieve the Contractor from responsibility, nor impose liability on the Authority, for nonconforming supplies.
- (k) Inspections and tests by the Authority does not relieve the Contractor of responsibility for defects or other failures to meet contract requirements discovered before acceptance. Acceptance shall be conclusive, except for latent defects, fraud, gross mistakes amounting to fraud, or as otherwise provided in the contract.
- (l) If acceptance is not conclusive for any of the reasons in paragraph (k) hereof, the Authority, in addition to any other rights and remedies provided by law, or under other provisions of this contract, shall have the right to require the Contractor:

- (1) At no increase in contract price, to correct or replace the defective or nonconforming supplies at the original point of delivery or at the Contractor's plant at the Contracting Officer's election, and in accordance with a reasonable delivery schedule as may be agreed upon between the Contractor and the Contracting Officer; provided, that the Contracting Officer may require a reduction in contract price if the Contractor fails to meet such delivery schedule, or
- (2) Within a reasonable time after receipt by the Contractor of notice of defects or nonconformance, to repay such portion of the contract as is equitable under the circumstances if the Contracting Officer elects not to require correction or replacement. When supplies are returned to the Contractor, the Contractor shall bear the transportation cost from the original point of delivery to the Contractor's plant and return to the original point when that point is not the Contractor's plant. If the Contractor fails to perform or act as required in paragraphs (1) or (2) above and does not cure such failure within a period of 10 days (or such longer period as the Contracting Officer may authorize in writing) after receipt of notice from the Contracting Officer specifying such failure, the Authority shall have the right by contract or otherwise to replace or correct such supplies and charge to the Contractor the cost occasioned the Authority thereby.

22. LIMITATION ON WITHHOLDING PAYMENTS

If more than one (1) clause or schedule provision of this Contract authorizes the temporary withholding of amounts otherwise payable to the Contractor for supplies delivered or services performed, the total of the amounts so withheld at any one (1) time shall not exceed the greatest amount which may be withheld under any one such clause or schedule provision at that time; provided, that this limitation shall not apply to:

- (a) Withholdings pursuant to any clause relating to wages or hours of employees;
- (b) Withholdings not specifically provided for by this Contract;
- (c) The recovery of overpayment; and
- (d) Any other withholding for which the Contracting Officer determines that this limitation is inappropriate.

23. NEW MATERIAL (SUPPLIES)

Unless this Contract specifies otherwise, the Contractor represents that the supplies and components to be provided under this Contract are new (not used or reconditioned, and not of such age or so deteriorated as to impair their usefulness or safety). If at any time during the performance of this Contract, the Contractor believes that furnishing supplies or components which are not new is in the Authority's best interest, the Contractor shall notify the Contracting Officer immediately in writing. The Contractor's notice shall include the reasons for the request, along with a bid for any consideration to the Authority if the Contracting Officer authorize to the use of such supplies or components.

24. NOTICE AND ASSISTANCE REGARDING PATENT AND COPYRIGHT INFRINGEMENT (SUPPLIES)

- (a) The Contractor shall report to the Contracting Officer, promptly and in reasonable written detail, each notice or claim of patent or copyright infringement based on the performance of this Contract of which the Contractor has knowledge.
- (b) In the event of any claim or suit against the Authority on account of any alleged patent or copyright infringement arising out of the performance of this Contract or out of the use of any supplies furnished or work or services performed hereunder, the Contractor shall furnish to the Authority, when requested by the Contracting Officer, all evidence and information in possession of the Contractor pertaining to such suit or claim. Such evidence and information shall be furnished at the expense of the Authority except where the Contractor has agreed to indemnify the Authority.
- (c) This clause shall be included in all subcontracts.

25. NOTICE TO THE AUTHORITY OF LABOR DISPUTES

- (a) Whenever the Contractor has knowledge that any actual or potential labor dispute is delaying or threatens to delay the timely performance of this Contract, the Contractor shall immediately give notice thereof, including all relevant information with respect thereto, to the Contracting Officer.
- (b) The Contractor agrees to insert the substance of this clause, including this paragraph (b), in any subcontract hereunder as to which a labor dispute may delay the timely performance of this Contract; except that each such subcontract shall provide that in the event its timely performance is delayed or threatened by delay by any actual or potential labor dispute, the subcontractor shall immediately notify his next higher tier subcontractor, or the Contractor, as the case may be, of all relevant information with respect to such dispute.

26. OFFICIALS NOT TO BENEFIT

- (a) No member of or delegate to Congress, or resident commissioner, shall be admitted to any share or part of this Contract, or to any benefit that may arise there from; but this provision shall not be construed to extend to this Contract if made with a corporation for its general benefit.
- (b) No member, officer or employee of the Public Body or of a local public body during his tenure or one year thereafter shall have any interest, direct or indirect, in this Contract or the proceeds thereof.
- (c) Enforcement of this clause shall be consistent with 18 U.S.C. §431.

27. ORDER OF PRECEDENCE

In the event of an Any inconsistency in this solicitation or Contract shall be resolved by giving precedence in the following order: (a) the Bid Schedule; (b) representations and other instructions; (c) General Provisions; (d) other provisions of the Contract, whether incorporated

by reference or otherwise; (e) other documents, exhibits, and attachments; (f) the specifications or statement of work; and (g) drawings, if any.

28. ORGANIZATIONAL CONFLICT OF INTEREST

- (a) An organizational conflict of interest exists when the nature of the work to be performed under a proposed contract or subcontract may, without some restriction on future activities (1) result in an unfair competitive advantage to the contractor or subcontractor; or (2) impair the contractor's objectivity in performing the contracted work. Most typically this would arise when a contractor prepares a design or specification for work that is to be procured competitively. It may also arise when a contractor or one of its affiliates would have an economic interest in the outcome of a contract or project. Conflicts of interest may be either real or apparent.
- (b) In the event that an Offeror believes that it or any of its potential subcontractors may have an organizational conflict of interest, it shall notify the Contracting Officer, in writing, within five (5) work days after it becomes aware of the potential or actual organizational conflict of interest. The written notification shall identify the nature and circumstances of the perceived conflict and propose appropriate measures to eliminate or mitigate the situation. The Contracting Officer will review the circumstances and the proposed mitigation and notify the Offeror accordingly, determining that: (1) no mitigation is required; (2) the conflict cannot be mitigated; or (3) the conflict can be mitigated and accepts the proposed measures, or recommends additional measures.
- (c) The failure of an Offeror to identify such perceived conflicts may result in: (1) the Offeror being disqualified from the competition; or (2) any contract award being rescinded or terminated for default.
- (d) Should a successful Offeror identify or become aware of a conflict after award, including any extension of the contract, which it could not reasonably have anticipated prior to award, it shall notify the Contracting Officer in accordance with paragraph (b) above, or request an exception to the restriction with supporting rationale. The Contracting Officer shall consider the Contractor's proposed measures to mitigate or eliminate the conflict, or the request for an exception.
 - (1) If the proposed measures are not determined feasible nor acceptable to the Contracting Officer, the Contracting Officer may terminate the contract in accordance with the TERMINATION FOR CONVENIENCE OF THE AUTHORITY provisions of the contract; or
 - (2) If the request for an exception is not granted by the Contracting Officer, and the contract is not terminated for convenience, the Contractor shall be notified in writing and be given ten (10) days from the date of the written notification to take all necessary action to comply with the requirements of this clause.
 - (3) If the proposed measures are determined acceptable to the Contracting Officer, the Contracting Officer may grant a specific exception to this restriction, when in the Contracting Officer's judgment, the exception will not create a conflict between the Contractor's duties and obligations under this contract and the duties and obligations imposed on the Contractor under the contractual or other relationship for which an exception is requested.

SUPPLY AND SERVICE CONTRACT

IFB-FQ12235/CPR

- (e) If the Contractor fails to comply with the terms of this clause, the Contracting Officer, may withhold payments due under the contract until such time as the Contractor is in compliance or, should the non-compliance remain uncorrected at the expiration of ten (10) days from written notice from the Contracting Officer as provided in §(d)(2) of this clause, terminate the contract for default pursuant to the Default clause of this contract.
- (f) The Contractor, in performing this Contract, shall avoid any conduct which might result in or give the appearance of creating for Directors, Officers, or employees of the Authority in their relationship with the Contractor, any conflicts of interest or favoritism and/or the appearance thereof and shall avoid any conduct which might result in a Director, Officer, or employee failing to adhere to the Standards of Conduct adopted by the Authority's Board of Directors.
- (g) Any determination by the Contracting Officer under this clause shall be final and shall be considered a question of fact within the meaning of the Disputes clause of this Contract.

29. PATENT INDEMNITY

The Contractor shall indemnify the Authority and its officers, agents and employees against liability, including costs, for infringement of any United States patent (except a patent issued upon an application that is now or may hereafter be withheld from issue pursuant to a Secrecy Order under 35 U.S.C. 181) arising out of the manufacture or delivery of supplies, the performance of services, or the construction, alteration, modification, or repair of real property ("hereinafter referred to as "construction work") under this Contract. This indemnity shall not apply unless the Contractor is informed as soon as practicable by the Authority of the suite or action alleging such infringement, and is given such opportunity as is afforded by applicable laws, rules, or regulations to participate in the defense thereof; and further, such indemnity shall not apply to:

- (1) An infringement resulting from compliance with specific written instructions of the Contracting Officer directing a change in the supplies to be delivered or in the materials or equipment to be used, or directing a manner or performance of the Contract not normally used by the Contractor;
- (2) An infringement resulting from addition to, or change in, such supplies or components furnished or construction work performed that was made subsequent to delivery or performance by the Contractor; or
- (3) A claimed infringement which is unreasonably settled without the consent of the Contractor, unless required by final decree of court of competent jurisdiction.

30. PAYMENTS

The Authority shall pay the Contractor, normally within 30 days of receipt of a properly prepared invoice or voucher, the prices stipulated in this contract for supplies delivered and accepted or services rendered and accepted, less any deductions provided in this contract.

31. PAYMENT DEDUCTIONS - NONCOMPLIANCE WITH DBE REQUIREMENTS

- (a) For federally funded contracts that exceed \$100,000 and to which the Disadvantage Business Enterprise (DBE) Requirements (Appendix B) apply, the failure to perform in

WASHINGTON METROPOLITAN AREA TRANSIT AUTHORITY

SUPPLY AND SERVICE CONTRACT

IFB-FQ12235/CPR

accordance with requirements of Appendix B may result in a partial or full suspension of payment, including progress payments, if applicable.

- (b) If the Contractor is found to be in noncompliance with the DBE requirements of Appendix B, the progress of the work shall also be deemed to be unsatisfactory, and an amount equal to the DBE participation in the Contract shall be retained from payment (or progress payments, if any) made to the Contractor.
- (c) If the Contractor fails to submit the required monthly DBE reports, the Contracting Officer may suspend payment (or progress payments) until such time as the monthly reports are submitted and accepted by the Authority.

32. PRICE REDUCTION FOR DEFECTIVE COST OR PRICING DATA - MODIFICATIONS

- (a) This clause shall become operative only with respect to any modification of this Contract which involves aggregate increases and/or decreases in costs plus applicable profits in excess of \$100,000 unless the modification is priced on the basis of adequate competition, established catalog or market prices of commercial items sold in substantial quantities to the general public, or prices set by law or regulation. The right to price reduction under this clause is limited to defects in data relating to such modification.
- (b) If any price, including profit, or fee, negotiated in connection with any modification for price adjustment under this Contract, was increased by any significant amount because of (b)(1) or (3) of this clause, the price or cost shall be reduced accordingly and the contract shall be modified to reflect the reduction. This right to a price reduction is limited to that resulting from defects in data relating to modifications for which this clause becomes operative under paragraph (a) of this clause.
 - (1) The Contractor or a subcontractor furnished cost or pricing data that were which was not complete, accurate, and current as certified in the Contractor's Certificate of Current Cost or Pricing Data;
 - (2) A subcontractor or prospective subcontractor furnished the Contractor cost or pricing data that were not complete, accurate, and current as of the date certified in the Contractor's Certificate of Current Cost or Pricing Data; or
 - (3) Any reduction in the Contract price due to defective subcontract data of a prospective subcontractor, when the subcontract was not subsequently awarded to such subcontractor, shall be limited to the amount (plus applicable overhead and profit markup) by which the actual subcontract, or the actual cost to the Contractor, if there was no subcontract, was less than the prospective subcontract cost estimate submitted by the Contractor, provided that the actual subcontract price was not affected by defective cost or pricing data.
- (c) If the Contractor includes a clause an article similar to this clause in any subcontract, such subcontract clause shall be solely between the Contractor and the subcontractor and not binding on the Authority.

33. PRICING OF ADJUSTMENTS

- (a) When costs are a factor in any determination of a Contract price adjustment pursuant to the CHANGES AND CHANGED CONDITIONS clause or any other provision of this Contract, such costs shall be in accordance with the Subpart 31.1 of the Federal Acquisition Regulations (48 CFR 31.1).
- (b) Notwithstanding any interpretation of the aforementioned contract cost principles and procedures to the contrary, the Authority will not be liable for interest, however represented, on or as a part of any claim, request, bid or adjustment, including equitable adjustments, whether said claim, request, bid or adjustment, including equitable adjustments, arises under the Contract or otherwise.
- (c) Where general and administrative expense is recoverable as part of any pricing adjustment under this contract, the adjustment shall be based on the relationship between the Contractors' total general and administrative expenses allowable under FAR cost principles for all construction-type operations, during the fiscal or calendar year covering the actual performance period of the work included in this pricing adjustment, and the Contractor's total cost input (excluding General and Administrative costs) for construction-type operations during the same period, expressed as a percentage, applied to the direct and overhead contract costs included in the pricing adjustment.

34. RESPONSIBILITY FOR INSPECTION

Notwithstanding the requirements for any Authority inspection and test contained in Specifications applicable to this Contract, except where specialized inspections or tests are specified for performance solely by the Authority, the Contractor shall perform or have performed the inspections and tests required to substantiate that the supplies and services provided under the Contract conform to the Drawings, Specifications and Contract requirements.

35. RETENTION OF DOCUMENTS

Except where this Contract specifically requires otherwise, the Contractor shall retain for a period of three (3) years from final payment, all research and supporting documentation, work papers and other documents, whether written or electronic, used in the performance of services for this Contract.

36. RIGHTS IN TECHNICAL DATA

- (a) The Authority shall have the right to use, duplicate, or disclose technical data, which includes computer software, in whole or in part, in any manner and for any purpose whatsoever, and to have or permit others to do so:
 - (1) Any manuals, instructional materials prepared for installation, operation, maintenance or training purposes;
 - (2) Technical data pertaining to end items, components or processes which were prepared for the purpose of identifying sources, size, configuration, mating and attachment characteristics, functional characteristics and performance

WASHINGTON METROPOLITAN AREA TRANSIT AUTHORITY

SUPPLY AND SERVICE CONTRACT

IFB-FQ12235/CPR

- requirements ("form, fit and function" data; e.g., specification control drawings, catalog sheets, outline drawing; except that for computer software it means data identifying source, functional characteristics, and performance requirements but specifically excludes the source code, algorithm, process, formulae, and flow charts of the software);
- (3) Other technical data which has been, or is normally furnished without restriction by the Contractor or subcontractor; or
 - (4) Other specifically described technical data which the parties have agreed will be furnished without restriction.
- (b) The Authority shall have the right to use, duplicate, or disclose technical data other than that defined in paragraph (a) in whole or in part, with the express limitation that such technical data shall not, without the written permission of the party furnishing such technical data, be
- (1) Released or disclosed in whole or in part outside the Authority;
 - (2) Used in whole or in part by the Authority for manufacture; or
 - (3) Used by a party other than the Authority except for emergency repair or overhaul work only, by or for the Authority where the item or process concerned is not otherwise reasonably available to enable timely performance of the work; provided, that the release or disclosure thereof outside the Authority shall be made subject to a prohibition against further use, release or disclosure.
- (c) Technical data provided in accordance with the provisions of paragraph (b) shall be identified by a legend which suitably recites the aforesaid limitation. Nothing herein shall impair the right of the Authority to use similar or identical data acquired from other sources.
- (d) The term technical data as used in this clause means technical writing, computer software, sound recordings, pictorial reproductions, drawings, or other graphic representations and works of a technical nature, whether or not copyrighted, which are specified to be delivered pursuant to this Contract. The term does not include financial reports, cost analyses, and other information incidental to Contract administration. Computer software as used in this clause means computer programs, computer data bases, and documentation thereof.
- (e) Material covered by copyright:
- (1) The Contractor agrees to and does hereby grant to the Authority, and to its officers, agents and employees acting within the scope of their official duties, a royalty-free, nonexclusive and irrevocable license throughout the world for Authority purposes to publish, translate, reproduce, deliver, perform, dispose of, and to authorize others so to do, all technical data now or hereafter covered by copyright.
 - (2) No such copyrighted matter shall be included in technical data furnished hereunder without the written permission of the copyright owner for the Authority to use such copyrighted matter in the manner above described.

- (3) The Contractor shall report to the Authority (or higher-tier contractor) promptly and in reasonable written detail each notice or claim of copyright infringement received by the Contractor with respect to any technical data delivered hereunder.
- (f) Relation to patents: Nothing contained in this clause shall imply a license to the Authority under any patent, or be construed as affecting the scope of any license or other right otherwise granted to the Authority under any patent.
- (g) Any dispute under this clause article shall be subject to the Disputes clause of this contract.
- (h) Notwithstanding any other payment provision in this contract, the Contracting Officer may retain from payment up to 10 percent of the contract price until final delivery and acceptance of the technical data defined in this clause and as required to be furnished by the bid schedule or the contract specification.

37. ROYALTY INFORMATION

- (a) When the response to this solicitation contains costs or charges for royalties totaling more than \$250, the following information shall be furnished with the offer, bid, or quotation on each separate item of royalty or license fee:
 - (1) Name and address of licensor;
 - (2) Date of license agreement;
 - (3) Patent numbers, patent application serial numbers or other basis on which the royalty is payable;
 - (4) Brief description, including any part or model numbers of each contract item or component on which the royalty is payable;
 - (5) Percentage or dollar rate of royalty per unit;
 - (6) Unit price or Contract item;
 - (7) Number of units; and
 - (8) Total dollar amount of royalties.
- (b) In addition, if specifically requested by the Contracting Officer prior to execution of the Contract, a copy of the current license agreement and identification of applicable claims of specific patents shall be furnished.

38. SEAT BELT USE POLICY

The contractor agrees to comply with terms of Executive Order No. 13043 "Increasing Seat Belt Use in the United States" and is encouraged to include those requirements in each subcontract awarded for work relating to this contract.

39. SENSITIVE SECURITY INFORMATION

The contractor must protect, and take measures to assure that its subcontractors at each tier protect, "sensitive information" made available during the course of administering an Authority contract or subcontract in accordance with 49 U.S.C. Section 40119(b) and implementing DOT regulations, "Protection of Sensitive Security Information," 49 CFR Part 15, and with 49 U.S.C. Section 114(s) and implementing Department of Homeland Security regulations, "Protection of Sensitive Security Information," 49 CFR Part 1520.

40. STOP WORK ORDER

(a) The Contracting Officer may, at any time, by written order to the Contractor, require the Contractor to stop all, or any part of the work called for by this Contract for a period of 90 days after the order is delivered to the Contractor, and for any further period to which the parties may agree. The order shall be specifically identified as a STOP WORK ORDER issued under this clause. Upon receipt of the order, the Contractor shall immediately comply with its terms and take all reasonable steps to minimize the incurrence of costs allocable to the work covered by the order during the period of work stoppage. Within a period of 90 days after a stop work order is delivered to the Contractor, or within any extension of that period to which the parties shall have agreed, the Contracting Officer shall either:

- (1) Cancel the stop work order; or
- (2) Terminate the work covered by such order as provided in the DEFAULT or TERMINATION FOR CONVENIENCE OF THE AUTHORITY clauses of this Contract.

(b) If a stop work order issued under this clause is cancelled or the period of the order or any extension thereof expires, the Contractor shall resume work. An equitable adjustment shall be made in the delivery schedule or Contract price, or both, and the Contract modified in writing accordingly, if:

- (1) The stop work order results in an increase in the time required for, or in the Contractor's cost properly allocable to, the performance of any part of this Contract; and
- (2) The Contractor asserts a claim for such adjustment within 30 days after the end of the period of work stoppage; provided that, if the Contracting Officer decides the facts justify such action, he may receive and act upon any such claim submitted at any time before final payment under this Contract.

(c) If a stop work order is not cancelled and the work covered by the order is terminated for the convenience of the Authority, the Contracting Officer shall allow reasonable costs resulting from the stop work order shall be allowed in arriving at the termination settlement.

(d) If a stop work order is not cancelled and the work covering by the order is terminated for default, the Contracting Officer shall allow, by equitable adjustment or otherwise, reasonable costs resulting from the stop-work order.

41. SUBCONTRACTOR COST AND PRICING DATA-PRICE ADJUSTMENTS

- (a) Paragraphs (b) and (c) of this clause shall become operative only with respect to any change or other modification made pursuant to one or more provisions of this Contract which involves a price adjustment in excess of \$100,000. The requirements of this clause shall be limited to such price adjustments.
- (b) The Contractor shall require subcontractors hereunder to submit cost or pricing data under the following circumstances:
 - (1) Prior to award of any cost-reimbursement type, incentive, or price re-determinable subcontract;
 - (2) Prior to the award of any subcontract the price of which is expected to exceed \$100,000; and
 - (3) Prior to the pricing of any subcontract change or other modification for which the price adjustment is expected to exceed \$100,000; except in the case of (b)(2) or (3) where the price is based on adequate price competition, established catalog or market prices of commercial items sold in substantial quantities to the general public, or prices set by law or regulation.
- (c) The Contractor shall require subcontractors to certify that to the best of their knowledge and belief, the cost and pricing data submitted under paragraph (b) of this clause, is accurate, complete, and current as of the date of execution, which date shall be as close as possible to the date of agreement on the negotiated price of the Contract modification.
- (d) The Contractor shall insert the substance of this clause including this paragraph (d) in each subcontract which exceeds \$100,000.

42. SUBCONTRACTOR PAYMENTS

- (a) The Contractor shall, under this contract, establish procedures to ensure timely payment of amounts due pursuant to the terms of its subcontracts. The Contractor shall pay each subcontractor for satisfactory performance of its contract, or any billable portion thereof, no later than ten (10) days from the date of the Contractor's receipt of payment from the Authority for work by that subcontractor. The Contractor shall also release, within ten (10) days of satisfactory completion of all work required by the subcontractor, any retention withheld from the subcontractor.
- (b) The Contractor shall certify on each payment request to the Authority that payment has been or will be made to all subcontractors in accordance with paragraph (a) above for previous payments by the Authority to the Contractor. The Contractor shall notify the Contracting Officer or other delegated Authority representative with each payment request, of any situation in which scheduled subcontractor payments have not been made.
- (c) If a subcontractor alleges that the Contractor has failed to comply with this provision, the Contractor agrees to support any Authority investigation, and, if deemed

WASHINGTON METROPOLITAN AREA TRANSIT AUTHORITY

SUPPLY AND SERVICE CONTRACT

IFB-FQ12235/CPR

appropriate by the Authority, to consent to remedial measures to ensure subcontractor payment that is due.

- (d) The Contractor agrees that the Authority may provide appropriate information to interested subcontractors who want to determine the status of Authority payments to the Contractor.
- (e) Nothing in this provision is intended to create a contractual obligation between the Authority and any subcontractor or to alter or affect traditional concepts of privity of contract between all parties.

43. TERMINATION FOR CONVENIENCE OF THE AUTHORITY

- (a) The Authority may terminate performance of work under this Contract in whole, or from time to time, in part, if the Contracting Officer determines that a termination is in the Authority's interest. The Contracting Officer shall terminate by delivering to the Contractor a Notice of Termination specifying the extent of termination and the effective date.
- (b) After receipt of a Notice of Termination, and except as otherwise directed by the Contracting Officer, the Contractor shall immediately proceed with the following obligations, regardless of any delays in determining or adjusting any amounts due under the clause:
 - (1) Stop work as specified in the Notice of Termination;
 - (2) Place no further subcontracts or orders (referred to as subcontracts in this clause) for materials, services, or facilities, except as necessary to complete the continued portion of the contract;
 - (3) Terminate all subcontracts to the extent that they relate to the work terminated;
 - (4) Assign to the Authority, as directed by the Contracting Officer, all right(s), title, and interest of the Contractor under the subcontracts terminated, in which case the Authority shall have the right to settle or pay any termination settlement bid arising out of those terminations;
 - (5) With approval or ratification to the extent required by the Contracting Officer, settle all outstanding liabilities and termination settlement bids arising from the termination of subcontracts; the approval or ratification will be final for all the purposes of this clause;
 - (6) As directed by the Contracting Officer, transfer title and deliver to the Authority:
 - (i) The fabricated or un-fabricated parts, work in process, completed work, supplies, and other material produced or acquired for the work terminated; and
 - (ii) The completed or partially completed plans, drawings, information and other property that, if the Contract had been completed, would be required to be furnished to the Authority.

WASHINGTON METROPOLITAN AREA TRANSIT AUTHORITY

SUPPLY AND SERVICE CONTRACT

IFB-FQ12235/CPR

- (7) Complete performance of the work not terminated;
 - (8) Take any action that may be necessary, or as the Contracting Officer may direct, for the protection and preservation of the property related to this Contract that is in the possession of the Contractor and in which the Authority has or may acquire an interest;
 - (9) Use its best efforts to sell, as directed or authorized by the Contracting Officer, any property of the types referred to in paragraph (b)(6) of this clause; provided, however, that the Contractor (a) is not required to extend credit to any purchaser and (b) may acquire the property under the conditions prescribed by, and at prices approved by, the Contracting Officer. The proceeds of any transfer or disposition will be applied to reduce payments to be made by the Authority under this contract, credited to the price or cost of the work, or paid in any other manner directed by the Contracting Officer.
- (c) The Contractor shall submit complete termination inventory schedules not later than 120 days from the effective date of termination, unless extended in writing by the Contracting Officer upon written request of the Contractor within the 120-day period.
- (d) After expiration of the plant clearance period (as defined in Subpart 49.001 of the Federal Acquisition Regulation), the Contractor may submit to the Contracting Officer a list, certified as to quantity and quality, of termination inventory not previously disposed of, excluding items authorized for disposition by the Contracting Officer. The Contractor may request the Authority to remove those items or enter into an agreement for their storage. Within 15 days thereafter, the Authority will accept title to those items and remove them or enter into a storage agreement. The Contracting Officer may verify the list upon removal of the items, or if stored, within 45 days from submission of the list, and shall correct the list, as necessary, before final settlement.
- (e) After termination, the Contractor shall submit a final termination settlement proposal to the Contracting Officer in the form and with the certification prescribed by the Contracting Officer. The Contractor shall submit the bid promptly, but no later than 1 year from the effective date of termination, unless extended in writing by the Contracting Officer upon written request of the Contractor within this 1-year period. However, if the Contracting Officer determines that the facts justify it, a termination settlement proposal may be received and acted upon after 1 year or any extension. If the Contractor fails to submit the bid within the time allowed, the Contracting Officer may determine, on the basis of information available, the amount, if any, due the contractor because of the termination and shall pay the amount determined.
- (f) Subject to paragraph (e) this clause, the Contractor and the Contracting Officer may agree upon the whole or any part of the amount to be paid or remaining to be paid because of the termination. The amount may include a reasonable allowance for profit on work done. However, the agreed amount, whether under this paragraph (f) or paragraph (g) of this clause, exclusive of costs shown in paragraph (g)(3) of this clause, may not exceed the total contract price as reduced by (1) the amount of payment previously made and (2) the contract of price of work not terminated. The contract shall be modified, and the Contractor paid the agreed amount. Paragraph (g) of this clause does not limit, restrict, or affect the amount that may be agreed upon to be paid under this paragraph.

WASHINGTON METROPOLITAN AREA TRANSIT AUTHORITY

SUPPLY AND SERVICE CONTRACT

IFB-FQ12235/CPR

- (g) If the Contractor and the Contracting Officer fail to agree on the whole amount to be paid because of the termination of work, the Contracting Officer shall pay the Contractor the amounts determined by the Contracting Officer as follows, but without duplication of any amounts agreed on under paragraph (f) of this clause:
- (1) The contract price for completed supplies or services accepted by the Authority (or sold or acquired under paragraph (b)(9) of this clause) not previously paid for, adjusted for any saving of freight and other charges.
 - (2) The total of:
 - (i) The costs incurred in the performance of the work terminated, including initial costs and preparatory expense allocable thereto, but excluding any costs attributable to items compensated or to be paid for under paragraph (g)(1) of this clause;
 - (ii) The cost of settling and paying termination settlement proposals under terminated subcontracts that are properly chargeable to the terminated portion of the contract if not excluded in subsection (g)(2)(i) of this clause; and
 - (iii) A sum, as profit on subdivision (g)(2)(i) of this clause, determined by the Contracting Officer pursuant to Section 49.202 of the Federal Acquisition Regulation, in effect on the date of this contract, to be fair and reasonable; however if it appears that the Contractor would have sustained a loss on the entire Contract had it been completed, the Contracting Officer shall allow no profit under this subsection (g)(2)(iii) and reduce the settlement to reflect the indicated rate of loss.
 - (3) The reasonable costs of settlement of the work terminated, including:
 - (i) Accounting, legal, clerical, and other expenses reasonably necessary for the preparation of termination settlement proposals and supporting data;
 - (ii) The termination and settlement of subcontracts (excluding the amounts of such settlements); and
 - (iii) Storage, transportation, and other costs incurred, reasonably necessary for the preservation, protection, or disposition of the termination inventory.
- (h) Except for normal spoilage, and except to the extent that the Authority expressly assumed the risk of loss, the Contracting Officer shall exclude from the amounts payable to the Contractor under paragraph (g) of this clause, the fair value, as determined by the Contracting Officer, of property that is destroyed, lost, stolen, or damaged so as to become undeliverable to the Authority or to a buyer.
- (i) The cost principles and procedures of Part 31 of the Federal Acquisition Regulation, in effect on the date of this contract, shall govern all costs claimed, agreed to, or determined under this clause.

WASHINGTON METROPOLITAN AREA TRANSIT AUTHORITY

SUPPLY AND SERVICE CONTRACT

IFB-FQ12235/CPR

- (j) The Contractor shall have the right of appeal, under the DISPUTES clause, from any determination made by the Contracting Officer under paragraph (e), (g) or (1) of this clause, except that if the Contractor failed to submit the termination settlement proposal or request for equitable adjustment within the time provided in paragraph (e) or (1) respectively, and failed to request a time extension, there is no right of appeal.
- (k) In arriving at the amount due the Contractor under this clause, there shall be deducted:
- (1) All un-liquidated advances or other payments to the Contractor under the terminated portion of the Contract;
 - (2) Any claim which the Authority has against the Contractor under this contract; and
 - (3) The agreed price for, or the proceeds of sale of, materials, supplies, or other things procured by the Contractor or sold under the provisions of this clause and not recovered by or credited to the Authority.
- (l) If the termination is partial, the Contractor may file a bid with the Contracting Officer for an equitable adjustment of the price(s) of the continued portion of the Contract. The Contracting Officer shall make any equitable adjustment agreed upon. Any bid by the Contractor for an equitable adjustment under this clause shall be requested within 90 days from the effective date of termination unless extended in writing by the Contracting Officer.
- (m) (1) The Authority may, under such terms and conditions it prescribes, make partial payments and payments against costs incurred by the Contractor for the terminated portion of the Contract, if the Contracting Officer believes the total of these payments will not exceed the amount to which the contractor will be entitled.
- (2) If the total payments exceed the amount finally determined to be due, the Contractor shall repay the excess to the Authority upon demand, together with interest computed at the rate established by the Secretary of Treasury under 50 U.S.C. App. 1215(b)(2). Interest shall be computed for the period from the date the excess payment is received by the Contractor to the date the excess is repaid. Interest shall not be charged on any excess payment due to a reduction in the Contractor's termination settlement proposal because of retention or other disposition of termination inventory until 10 days after the date of the retention or disposition, or a later date determined by the Contracting Officer because of circumstances.
- (n) Unless otherwise provided in this Contract or by statute, the Contractor shall maintain all records and documents relating to the terminated portion of this contract for three (3) years after final settlement. This includes all books and other evidence bearing on the costs and expenses of the Contractor under this Contract. The Contractor shall make these records and documents available to the Authority, its governing jurisdictions and any other federal, state, or local entities providing funding for this Contract, and to the Comptroller General of the United States, or the agents or representatives of any of them, at the Contractor's office, at all reasonable times, without any direct charge. If approved by the Contracting Officer, photographs, microphotographs, or other authentic reproduction may be maintained instead of

WASHINGTON METROPOLITAN AREA TRANSIT AUTHORITY

SUPPLY AND SERVICE CONTRACT

IFB-FQ12235/CPR

original records and documents. This requirement shall be passed through to all subcontractors whose compensation is included in the termination settlement.

44. TITLE

Unless this Contract specifically provides for earlier passage of title to deliverables (including documents, reports, and data) or other items resulting from this Contract, title shall pass to the Authority upon formal acceptance, regardless of when or where the Authority takes physical possession. The risk of loss remains with the Contractor until the transfer of title.

45. VARIATION IN QUANTITY (SUPPLIES)

No variation in the quantity of any item called for by this Contract will be accepted unless such variation has been caused by conditions of loading, shipping, or packing, or allowances in manufacturing processes, and then only to the extent, if any, specified elsewhere in this Contract.

46. WALSH-HEALEY PUBLIC CONTRACTS ACT

If this Contract is for the manufacture or furnishing of materials, supplies, or equipment in an amount which exceeds or may exceed \$10,000 and is subject to the Walsh-Healey Public Contracts Act, as amended (41 U.S.C. 35-45), the following terms and conditions apply:

- (a) All stipulations required by the Act and regulations issued by the Secretary of Labor (41 CFR Chapter 50) are incorporated by reference. These stipulations are subject to all applicable rulings and interpretations of the Secretary of Labor that are now, or may be hereafter, be in effect.
- (b) All employees whose work relates to this contract shall be paid not less than the minimum wage prescribed by regulations issued by the Secretary of Labor (41 CFR 50-202.2). Learners, student learners, apprentices, and handicapped worker may be employed at less than the prescribed minimum wage (see 41 CFR 50-202.3) to the same extent that such employment is permitted under Section 14 of the Fair Labor Standards Act (41 U.S.C. 40).

SUPPLEMENTAL PROVISIONS REQUIRED IN FEDERALLY FUNDED CONTRACTS

47. ACCESS TO RECORDS

- (a) The Contractor agrees to provide the Authority, the FTA Administrator, the Comptroller General of the United States or any of their authorized representatives access to any books, documents, papers and records of the Contractor which are directly pertinent to this contract for the purposes of making audits, examinations, excerpts and transcriptions. The Contractor also agrees, pursuant to 49 CFR. 633.17 to provide the FTA Administrator or his authorized representatives including any PMO Contractor access to Contractor's records and construction sites pertaining to a major capital project, defined at 49 U. S. C. 5302(a)1, which is receiving federal financial assistance through the programs described at 49 U. S. C. 5307, 5309 or 5311.
- (b) The Contractor agrees to permit any of the foregoing parties to reproduce by any means whatsoever or to copy excerpts and transcriptions as reasonably needed.

WASHINGTON METROPOLITAN AREA TRANSIT AUTHORITY

SUPPLY AND SERVICE CONTRACT

IFB-FQ12235/CPR

- (c) The Contractor agrees to maintain all books, records, accounts and reports required under this contract for a period of not less than three years after the date of termination or expiration of this contract, except in the event of litigation or settlement of claims arising from the performance of this contract, in which case the Contractor agrees to maintain same until the Authority, the FTA Administrator, the Comptroller General, or any of their duly authorized representatives, have disposed of all such litigation, appeals, claims or exceptions related thereto. Reference 49 CFR 18.39(i)(11).

48. BUY AMERICA

The Buy America requirements apply to construction contracts and acquisitions for goods or rolling stock valued at more than \$100,000. The Contractor agrees to comply with 49 U.S.C. §5323(j) and its implementing regulations at 49 CFR Part 661, any amendments thereto and any implementing guidance issued by FTA. 49 CFR Part 661 provides that Federal funds may not be obligated unless steel, iron, and manufactured products used in FTA-funded projects are produced in the United States, unless a waiver has been granted by FTA or the product is subject to a general waiver. General waivers are listed in 49 CFR 661.7, and include 15 passenger wagons produced by Chrysler Corporation, microcomputer equipment including software of foreign origin, and small purchases (currently \$100,000 or less) made with Federal funds. In the case of rolling stock, the cost of components and sub-components produced in the United States must be more than 60 percent of the cost of all components of the rolling stock; and final assembly of the rolling stock must occur in the United States. This requirement applies to equipment acquired for, or in anticipation of, this Contract; it does not apply to equipment owned or leased by the Contractor, which was acquired prior to the issuance of the solicitation for this Contract, or which is purchased for the general use of the Contractor.

49. CARGO PREFERENCE REQUIREMENTS USE OF UNITED STATES FLAG VESSELS

The Contractor agrees:

- (a) To utilize privately owned United States-Flag commercial vessels to ship at least 50 percent of the gross tonnage (computed separately for dry bulk carriers, dry cargo liners, and tankers) involved, whenever shipping any equipment, materials, or commodities pursuant to this Contract to the extent such vessels are available at fair and reasonable rates for United States-Flag commercial vessels;
- (b) To furnish within 20 working days following the date of loading for shipments originating within the United States, or within 30 working days following the date of loading for shipments originating outside the United States, a legible copy of a rated, "on-board" commercial ocean bill-of-lading in English for each shipment of cargo described in paragraph (a) above to WMATA (through the Contractor in the case of a subcontractor's bills-of-lading) and to the Office of Cargo Preference, Maritime Administration (MAR-590), 400 Seventh Street SW, Washington, DC 20590;
- (c) To include these requirements in all subcontracts issued pursuant to this Contract when the subcontract may involve the transport of equipment, material, or commodities by ocean liner.

50. CLEAN AIR

- (a) The Contractor agrees to comply with all applicable standards, orders or regulations issued pursuant to the Clean Air Act, as amended, 42 U. S. C. §§ 7401 et seq. The Contractor agrees to report each violation to the Authority and understands and agrees that the Authority will, in turn, report each violation as required to FTA and the appropriate EPA Regional Office.
- (b) Flow-down requirement. The Contractor also agrees to include these requirements in each subcontract exceeding \$100,000 financed in whole or in part with Federal assistance provided by FTA.

51. CLEAN WATER

- (a) The Contractor agrees to comply with all applicable standards, orders or regulations issued pursuant to the Federal Water Pollution Control Act, as amended, 33 U. S. C. 1251 et seq. The Contractor agrees to report each violation to the Authority and understands and agrees that the Authority will, in turn, report each violation as required to assure notification to FTA and the appropriate EPA Regional Office.
- (b) Flow-down requirement. The Contractor also agrees to include these requirements in each subcontract exceeding \$100,000 financed in whole or in part with Federal assistance provided by FTA.

52. ENERGY CONSERVATION

- (a) The Contractor agrees to comply with mandatory standards and policies relating to the energy efficiency which are contained in the applicable state energy conservation plan issued in compliance with the Energy Policy and Conservation Act.
- (b) Flow-down requirement: The Contractor agrees to include the requirements of this clause in all subcontracts under this contract.

53. FEDERAL CHANGES

- (a) Contractor shall at all times comply with all applicable FTA regulations, policies, procedures and directives, including without limitation those listed directly or by reference in the Agreement (Form FTA MA (14) dated October 1, 2007) between the Authority and FTA, as they may be amended or promulgated from time to time during the term of this contract. Contractor's failure to so comply shall constitute a material breach of this contract.
- (b) Flow-down requirement. The Contractor agrees to include this clause in each subcontract financed in whole or in part with Federal Assistance provided by FTA. It is further agreed that the clause shall not be modified, except to identify the subcontractor who will be subject to its provisions.

54. FLY AMERICA REQUIREMENTS

- (a) The Contractor agrees to comply with 49 U. S. C. 40118 (the "Fly America" Act) in accordance with the General Services Administration's regulations at 41 CFR Part 301-

WASHINGTON METROPOLITAN AREA TRANSIT AUTHORITY

SUPPLY AND SERVICE CONTRACT

IFB-FQ12235/CPR

10, which provide that recipients and subrecipients of Federal funds and their contractors are required to use U. S. Flag carriers for U. S. Government-financed international air travel and transportation of their personal effects or property, to the extent such service is available, unless travel by foreign air carrier is a matter of necessity, as defined by the Fly America Act. The Contractor shall submit, if a foreign air carrier was used, an appropriate certification or memorandum adequately explaining why service by a U. S. flag carrier was not available or why it was necessary to use a foreign air carrier and shall, in any event, provide a certificate of compliance with the Fly America requirements.

- (b) Flow-down requirement. The Contractor agrees to include the requirements of this section in all subcontracts that may involve international air transportation.

55. GOVERNMENT-WIDE DEBARMENT OR SUSPENSION

- (a) The Contractor is bound by its certification contained in its offer to the Authority that neither the Contractor, its principals, or affiliates, are excluded or disqualified, as defined at 49 C.F.R. 29.940 and 29.945. The certification is a material representation of fact, relied upon by the Authority in entering into this Contract. If it is later determined that the Contractor knowingly rendered an erroneous certification, in addition to remedies available to the Authority, the Federal Government may pursue available remedies, including but not limited to suspension and/or debarment. The Contractor agrees to comply with the requirements of 49 C.F.R. 29, Subpart C, throughout the term of this Contract.

- (b) Flow-down requirement. The Contractor agrees to include this requirement in all subcontracts at all tiers under this Contract.

56. INCORPORATION OF FEDERAL TRANSIT ADMINISTRATION (FTA) TERMS

- (a) The preceding provisions include, in part, certain Standard Terms and Conditions required by the U.S. Department of Transportation (DOT), whether or not expressly set forth in the preceding contract provisions. All contractual provisions required by DOT, as set forth in FTA Circular 4220.1F or any revision thereto, are hereby incorporated by reference. Anything to the contrary herein notwithstanding, all DOT or FTA mandated terms shall be deemed to control in the event of a conflict with other provisions contained in this Agreement. The Contractor shall not perform any act, fail to perform any act, or refuse to comply with any Authority requests which would cause the Authority to be in violation of the FTA terms and conditions.

- (b) Flow-down requirement. The Contractor agrees to include this clause in each subcontract financed in whole or in part with Federal assistance provided by FTA. It is further agreed that the clause shall not be modified, except to identify the subcontractor who will be subject to the provisions.

57. LOBBYING

- (a) The Contractor is bound by its certification contained in its offer to the Authority regarding the use of federal or non-federal funds to influence, or attempt to influence any Federal officer or employee regarding the award, execution, continuation, or any similar action of any Federal grant or other activities as defined in 31 U.S.C. 1352, 49

WASHINGTON METROPOLITAN AREA TRANSIT AUTHORITY

SUPPLY AND SERVICE CONTRACT

IFB-FQ12235/CPR

CFR Part 19, or 49 C.F.R. Part 20. The Contractor agrees to comply with this requirement throughout the term of the Contract.

- (b) Flow-down requirement. The Contractor agrees to include these requirements in all subcontracts at all tiers under this Contract.

58. NO OBLIGATION BY THE FEDERAL GOVERNMENT

- (a) The Authority and the Contractor acknowledge and agree that, notwithstanding any concurrence by the Federal Government in or approval of the solicitation or award of this Contract, absent the express written consent by the Federal Government, the Federal Government is not a party to this Contract and shall not be subject to any obligations or liabilities to the Authority, Contractor, or any other party (whether or not a party to that contract) pertaining to any matter resulting from the underlying Contract.
- (b) Flow-down requirement. The Contractor agrees to include this clause in each subcontract financed in whole or in part with Federal Assistance provided by FTA. It is further agreed that the clause shall not be modified, except to identify the subcontractor who will be subject to its provisions.

59. PROGRAM FRAUD AND FALSE OR FRAUDULENT STATEMENTS AND RELATED ACTS

- (a) The Contractor acknowledges that the provisions of the Program Fraud Civil Remedies Act of 1986, as amended, 31 U. S. C. 3801 et seq and U. S. DOT Regulations, "Program Fraud Civil Remedies," 49 C.F. R. Part 31, apply to its actions pertaining to this Project. Upon execution of the underlying contract, the Contractor certifies and affirms the truthfulness and accuracy of any statement it has made, it makes, it may make, or causes to be made, pertaining to the underlying contract or the FTA assisted project for which this contract work is being performed. In addition to other penalties that may be applicable, the Contractor further acknowledges that if it makes or causes to be made, a false, fictitious, or fraudulent claim, statement, submission, or certification, the Federal Government reserves the right to impose the penalties of the Program Fraud Civil Remedies Act of 1986 on the Contractor to the extent the Federal Government deems appropriate.
- (b) The Contractor also acknowledges that if it makes, or causes to be made, a false, fictitious, or fraudulent claim, statement, submission, or certification to the Federal Government under a contract connected with a project that is financed in whole or in part with Federal assistance originally awarded by FTA under the authority of 49 U. S. C. 5307, the Government reserves the right to impose the penalties of 18 U. S. C. 1001 and 49 U. S. C 5307 (n)(1) on the Contractor, to the extent the Federal Government deems appropriate.
- (c) Flow-down requirement. The Contractor agrees to include this clause in each subcontract financed in whole or in part with Federal assistance provided by FTA. It is further agreed that the clause shall not be modified, except to identify the subcontractor who will be subject to the provisions.

60. RECOVERED MATERIALS

- (a) The Contractor agrees to comply with all the requirements of Section 6002 of the Resource Conservation and Recovery Act (RCRA) as amended (42 U. S. C. 6962),

WASHINGTON METROPOLITAN AREA TRANSIT AUTHORITY

SUPPLY AND SERVICE CONTRACT

IFB-FQ12235/CPR

including but not limited to the regulatory provisions of 40 CFR Part 247, and Executive Order 12873, as they apply to the procurement of the items designated in Subpart B of 40 CFR Part 247.

- (b) Flow-down requirement. The Contractor also agrees to include these requirements in each subcontract financed in whole or in part with Federal assistance provided by FTA

61. RIGHTS IN DATA AND COPYRIGHTS — FTA

- (a) The term "subject data" used in this section means recorded information, whether or not copyrighted, that is delivered or specified to be delivered under this contract. The term includes graphic or pictorial delineation in media such as drawings or photographs; text in specifications or related performance or design-type documents; machine forms such as punched cards, magnetic tape, or computer memory printouts; and information retained in computer memory. Examples include, but are not limited to: computer software, engineering drawings and associated lists; specifications, standards, process sheets, manuals, technical reports, catalog item identifications, and related information. The term "subject data" does not include financial reports, cost analyses, and similar information incidental to Project administration.
- (b) The following restrictions apply to all subject data first produced in the performance of this contract:
 - (1) Except for its or WMATA's own internal use, the Contractor may not publish or reproduce subject data in whole or in part, or in any manner or form, nor may the Contractor authorize others to do so, without the written consent of the U.S. Government, until such time as the Government may have either released or approved the release of such data to the public; this restriction on publication, however, does not apply to Agreements with academic institutions;
 - (2) In accordance with 49 C.F.R. § 18.34 and 49 C.F.R. 19.36, the Government reserves a royalty-free, non-exclusive and irrevocable license to reproduce, publish, or otherwise use, and to authorize others to use, the following subject data for Federal Government purposes:
 - (i) Any subject data developed under this contract whether or not a copyright has been obtained; and
 - (ii) Any rights of copyright to which the contractor purchases ownership with Federal assistance.
- (c) When the Federal Transit Administration (FTA) provides financial assistance for a planning, research, development, or a demonstration project, it is FTA's general intention to increase mass transportation knowledge, rather than limit the benefits of the Project to participants in the Project. Therefore, unless FTA determines otherwise, the Contractor agrees that, in addition to the rights set forth in subsection (b)(2) of this clause, FTA may make available to any FTA recipient, subrecipient, third party contractor, or third party subcontractor, either FTA's license in the copyright to the subject data derived under this contract or a copy of the subject data first produced under this contract. If this contract is not completed for any reason whatsoever, all data developed under this contract shall become subject data as defined in subsection (a) of this clause and shall be delivered as the Government may direct.

WASHINGTON METROPOLITAN AREA TRANSIT AUTHORITY

SUPPLY AND SERVICE CONTRACT

IFB-FQ12235/CPR

- (d) Unless prohibited by state law, the Contractor agrees to indemnify, save, and hold harmless WMATA and the Government, their officers, agents, and employees acting within the scope of their official duties against any liability, including costs and expenses, resulting from any willful or intentional violation by the contractor of proprietary rights, copyrights, or right of privacy, arising out of the publication, translation, reproduction, delivery, use, or disposition of any data furnished under this Contract. The Contractor shall not be required to indemnify WMATA and the Government for any such liability arising out of the wrongful acts of employees or agents of WMATA and the Government.
- (e) Nothing contained in this section on rights in data shall imply a license to WMATA or the Government under any patent or be construed as affecting the scope of any license or other right otherwise granted to WMATA or the Government under any patent.
- (f) The requirements of subsections (b) and (c), do not apply to material furnished by the Authority to the Contractor and incorporated in the work carried out under the contract provided that the Contractor identifies the incorporated material at the time of delivery of the work.
- (g) Any dispute under this clause shall be subject to the Disputes clause of this contract.
- (h) Notwithstanding any other payment provision in this contract, the Contracting Officer may retain from payment up to 10 percent (10 %) of the contract price until final delivery and acceptance of the subject data defined in this clause and as required to be furnished by the bid schedule or the contract specification.

SECTION 2
SPECIAL PROVISIONS

**SECTION 2
SPECIAL PROVISIONS**

1. PERIOD OF PERFORMANCE

Base Year 1 – date of award to June 30, 2013
Base Year 2 – July 1, 2013 – June 30, 2014
Option Year 1 – July 1, 2014 – June 30, 2015\
Option Year 2 – July 1, 2015 – June 30, 2016

2. PRICING

Prices submitted on the Price Schedule Sheets must include all associated costs, including but not limited to, delivery, freight, mark-ups, overhead, profit and etc.,.

3. REQUIREMENTS

Not Applicable

4. PAYMENT TERMS

- a. Discounts for prompt payment will not be considered in the evaluation of offers. However, any offered discount will form a part of the award, and will be taken if payment is made within the discount period indicated in the offer by the Offeror.
- b. Payments will be made upon delivery, inspection and satisfactory acceptance of equipment and receipt of a proper invoice.

5. AVAILABILITY OF FUNDS FOR THE NEXT FISCAL YEAR

Funds are not presently available for performance under this contract beyond the fiscal year which ends **June 30, 2013**. The Authority's obligation for performance of this contract beyond that date is contingent upon the availability of funds from which payment for contract purposes can be made. No legal liability on the part of the Authority for any payment may arise for performance under this contract until funds are made available to the Contracting Officer for performance and until the Contractor receives notice of availability, to be confirmed in writing, by the Contracting Officer. Any option exercised by the Authority which will be performed in whole or in part in a subsequent fiscal year is subject to availability of funds in the subsequent fiscal year is subject to availability of funds in the subsequent fiscal year and will be governed by the terms of this Article.

6. BILLING AND PAYMENT

- a. Payment will be made after receipt of a properly completed invoice. Mail original and one copy of all invoices to the Office of Accounting, WMATA, 6th Floor, 600 Fifth Street, NW, Washington, DC 20001. Also mail one copy of each invoice to the Contracting Officer's Technical Representative (COTR). A letter appointing the COTR will be included in the contract award package.

WASHINGTON METROPOLITAN AREA TRANSIT AUTHORITY

SUPPLY AND SERVICE CONTRACT

IFB-FQ12235/CPR

- b. Invoices shall be prepared and submitted in duplicate, sequentially numbered and contain the date, contract order number, item part number, description of product, quantity, unit prices, date of delivery, delivery location and extended totals.

7. POINT OF CONTACT

All inquiries are to be directed to:

Cathy Rooths
WMATA/PRMT
600 Fifth Street N. W.
Washington D. C. 20001
crooths@wmata.com
(202) 962-2469

8. F.O.B. DESTINATION

- a. The term "f.o.b. destination," as used in this clause, means---
- (1) Free of expense to WMATA on board the carrier's conveyance, at a specified delivery point where the consignee's facility (plant, warehouse, store, lot, or other location to which shipment can be made) is located; and
 - (2) Supplies shall be delivered to the destination consignee's warehouse unloading platform, or receiving dock, at the expense of the Contractor. WMATA shall not be liable for any delivery, storage, demurrage, accessorial, or other charges involved before the actual delivery (or "constructive placement" as defined in carrier tariffs) of the supplies to the destination, unless such charges are caused by an act or order of WMATA acting in its contractual capacity. If the Contractor uses rail carrier or freight forwarder for less than carload shipments, the Contractor shall assure that the carrier will furnish tailgate delivery if transfer to truck is required to complete delivery to consignee.
- b. The Contractor shall ---
- (1) Pack and mark the shipment to comply with contract specification;
 - (2) In the absence of specifications, prepare the shipment in conformance with carrier requirements;
 - (3) Prepare and distribute commercial bills of lading;
 - (4) Deliver the shipment in good order and condition to the point of delivery specified in the contract;
 - (5) Be responsible for any loss of and/or damage to the goods occurring before receipt of the shipment by the consignee at the delivery point specified in the contract;

WASHINGTON METROPOLITAN AREA TRANSIT AUTHORITY

SUPPLY AND SERVICE CONTRACT

IFB-FQ12235/CPR

- (6) Furnish a delivery schedule and designate the mode of delivering carrier;
and
- (7) Pay and bear all charges to the specified point of delivery.

9. CONTRACTOR PERSONNEL

OPTIONAL

- a. The Contractor shall replace employees who the Authority judges to be incompetent, careless, unsuitable or otherwise objectionable, or whose continued use is deemed contrary to the best interests of the program. The reason for replacement will be discussed between the Contractor and the Authority before a replacement request is issued. Upon receipt of a written request from the Authority, the Contractor shall proceed with the replacement unless the Contractor is able to demonstrate that the Authority's request is unreasonable. The replacement request will include the desired replacement date and the reason for the request. The Contractor shall effect the replacement in a manner that does not impact quality, cost or schedule.
- b. Contractor personnel required to work on WMATA property must obtain a WMATA vendors badge and successfully complete the mandatory safety training which must be renewed yearly. To obtain a vendors badge a signed waiver to perform a background check will be required.

10. PRE-EMPLOYMENT CRIMINAL BACKGROUND CHECK REQUIREMENT

Criminal background checks of all contractor employees working at a WMATA facility on this contract will be required. Eligibility for access to WMATA property will be based on WMATA's pre-employment Criminal Background Check criteria. WMATA will provide the contractor employees with background check consent forms that the contractor employees must complete and sign. The forms will require the contractor employees to appear in person, provide their full legal names, including middle initials if applicable, as well as their Social Security numbers, in addition to other information that will be necessary to conduct the background checks. The operating hours are Monday through Friday from 7:30AM B 3:30PM except holidays. Upon receipt of the completed, signed forms, WMATA will conduct background checks including criminal court searches and Social Security Number verifications of the contractor employees. If there is derogatory information that would disqualify a contractor employee from receiving a badge to access WMATA property, the Contractor and its contractor employee will be notified that the background check failed. The completed forms are secured in a locked file cabinet and are destroyed one year after the expiration date on the contractor employees badge. These background checks are expected to take one (1) business day for processing, so the contractor employee must allow sufficient time for completion. The background check is free of charge.

Background checks are conducted to promote a safe work environment and to protect our company's most important assets: the people we serve and the people with whom we serve. This enables WMATA management in making prudent decisions and maintaining a high quality workforce. Contractor employees who successfully complete the background checks are eligible to enter WMATA property once they are issued a contractor badge. On the other hand, contractor employees who do not authorize background checks or whose background checks are unsatisfactory will not be granted contractor badges or access to WMATA property. The records generated by these background checks that contain private information will not be disclosed unless disclosure is required under the PARP/Privacy Policies.

11. ORDERING

- a. Any supplies and services to be furnished under this contract shall be ordered by issuance of delivery orders from the duly authorized Contracting Officer, Ordering Officer, AR or COTR designated in the award document or subsequent letters. Such orders may be oral or by written telecommunication issued anytime during the life of this contract.
- b. All delivery orders are subject to the terms and conditions of this contract. In the event of a conflict between the delivery order and this contract, the contract shall control.
- c. If mailed, a delivery order is considered "issued" when WMATA deposits the order in the mail. Orders may be issued orally or electronically. Oral orders will be followed up by a written communication.
- d. Orders will include the following information:
 - (1) Date of the order;
 - (2) Contract number and an order number;
 - (3) Item number, description, quantity, and unit price;
 - (4) Delivery or performance date;
 - (5) Place of delivery or performance;
 - (6) Packaging, packing, and shipping instructions (if any);
 - (7) Accounting and appropriations data; and
 - (8) Any other pertinent information

12. WARRANTY

All costs incurred for the return of rejected fasteners and associated hardware will be at the expense of the successful bidder, Not WMATA. The successful bidder will be responsible for removing any rejected crossties and associated hardware within ten (10) days from the rejection notice.

13. INDEMNIFICATION

- a. Contractor shall indemnify, defend and hold harmless the Authority, its directors, officers, employees and agents, from all liabilities, obligations, damages, penalties, claims, costs, charges and expenses (including reasonable attorney's fees), of whatsoever kind and nature for injury, including personal injury or death of any person or persons, and for loss or damage to any property, including the property of the Contractor and the Authority, occurring in connection with, or in

WASHINGTON METROPOLITAN AREA TRANSIT AUTHORITY

SUPPLY AND SERVICE CONTRACT

IFB-FQ12235/CPR

any way arising out of the use, occupancy and performance of the work and/or any acts in connection with activities to be performed under this contract, unless the loss or damage is due to the sole negligence of the Authority. Nothing in the preceding sentence shall be deemed to relieve Contractor from ultimate liability for any obligation of Contractor under this Contract.

- b. Contractor shall indemnify, defend and hold harmless the Authority its directors, officers, employees and agents against any and all claims, liabilities, losses, demands, damages, penalties, costs, charges, remedial costs, environmental claims, fees or other expenses including attorneys fees, related to, arising from or attributable to any effluent or other hazardous waste, residue, contaminated soil or other similar material discharged from, removed from, or introduced on, about or under the job site, unless the loss or damage is due to the sole negligence of the Authority.

- c. If any action or proceeding relating to the indemnification required is brought against the Authority, then upon written notice from the Authority to the Contractor, the Contractor shall, at the Contractor's expense, resist or defend such action or proceeding by counsel approved by the Authority in writing, such approval not to be unreasonably withheld, but no approval of counsel shall be required where the cause of action is resisted or defended by counsel of any insurance carrier obligated to resist or defend the same. The Authority reserves the right to use its own counsel under this indemnity at Contractor's sole cost and expense.

- d. Contractor understands and agrees that it is Contractor's responsibility to provide indemnification to the Authority pursuant to this Section. The provision of insurance, while anticipated to provide a funding source for this indemnification, is in addition to any indemnification requirements and the failure of Contractor's insurance to fully fund any indemnification shall not relieve the Contractor of any obligation assumed under this indemnification.

14. INSURANCE REQUIREMENTS

Insurance - General Provisions

Contractor shall procure, at its sole cost and expense, and shall maintain in force at all times during the term of this Contract, including the Warranty Period if applicable, the insurance outlined in the section below. All insurance companies must have an A.M. Best rating of "A-/VII" or better and be approved by the Authority. All required insurance policies must

- 1. Be written in accordance with the requirements as applicable;
- 2. Be endorsed to include a provision that the policy shall not be canceled, materially changed, or nonrenewed without at least thirty (30) days prior written notice to the Authority's Office of Insurance;

WASHINGTON METROPOLITAN AREA TRANSIT AUTHORITY

SUPPLY AND SERVICE CONTRACT

IFB-FQ12235/CPR

3. State or be endorsed to provide that the coverage afforded under Contractor's policies shall apply on a primary basis and not on an excess or contributing basis with any policies that may be available to the Authority, and
4. Have self-insurance retentions or policy deductibles no greater than \$100,000, unless approved in writing by the Authority, whose approval shall not be unreasonably withheld.

The insurance limits required herein may be met through Contractor's primary and umbrella/excess policies. Policies must be written on an occurrence basis; a claims made basis is not acceptable, except for Professional Liability.

Contractor shall furnish evidence of all required insurance prior to the start of any work on Authority property. Certificates of insurance (COI) and all applicable endorsements may be submitted to the Authority in lieu of copies of insurance policies; if Railroad Protective Liability insurance and/or Builder's Risk insurance is required, the entire insurance policy must be sent to the Authority. However, the Authority reserves the right to request copies of policies of any required insurance as denoted below. If requested by the Authority, the Contractor shall deliver to the Authority within thirty (30) days of the request, a copy of such policies, certified by the insurance carrier as being true and complete.

COIs shall:

- 1) Disclose any deductible, sublimit, self-insured retention, aggregate limit or any exclusions to the policy that materially change the coverage;
- 2) Show the Authority as an additional insured for Commercial General Liability and Automobile Liability;
- 3) Reference the contract number, and
- 4) Expressly reference the inclusion of all required endorsements. All endorsements must include policy numbers.

Upon expiration of the policies, Contractor shall provide renewal COIs and all applicable endorsements to the Authority, with terms and limits no less favorable than the expiring insurance policies.

Evidence of insurance coverage – insurance certificates and endorsements (and the complete Railroad Protective Liability policy, if applicable) – stating the work to be performed shall be submitted to the Authority at least ten (10) business days prior to commencement of operations and from time to time at the Authority's request. Contractor shall not be allowed to proceed until the evidence of insurance has been received and approved in writing by the Authority. All evidence of insurance shall be sent to:

Washington Metropolitan Area Transit Authority

Office of Procurement, File Room 3C-04

600 5th Street, NW

Washington, DC 20001

WASHINGTON METROPOLITAN AREA TRANSIT AUTHORITY

SUPPLY AND SERVICE CONTRACT

IFB-FQ12235/CPR

With a copy to:

Washington Metropolitan Area Transit Authority

Office of Insurance, Room 8F

600 5th Street, NW

Washington, DC 20001

Required Insurance

1. Commercial General Liability Insurance with minimum limits of \$5,000,000 per occurrence / aggregate, written on an occurrence form. If the required minimum limits can only be met when applying an umbrella/excess liability policy, the umbrella/excess liability policy must follow form of the underlying policy and be extended to “drop down” to become primary in the event the primary limits are reduced or aggregate limits are exhausted. The coverage under such an insurance policy or policies shall be maintained for three (3) years and shall include the following coverage:

Products and completed operations liability

Independent contractors’ liability

Terrorism coverage

Additional Insured Endorsement naming WMATA

2. Workers’ Compensation Insurance meeting the statutory requirements of the jurisdiction where the work will be performed, including Employer’s Liability coverage with minimum limits of \$1,000,000 each accident or disease.

3. Auto Liability Insurance with a minimum combined single limit of \$2,000,000 per occurrence.

15. SAFETY/ENVIRONMENTAL REQUIREMENTS

Not Used.

16. SANITARY PROVISIONS

Not Used.

17. SUBCONTRACTS

Not Used.

18. LAWS AND REGULATIONS

Each Offeror shall be responsible to fully inform themselves of the requirements for and to comply with any applicable State of Maryland, Commonwealth of Virginia, District of Columbia, Federal and jurisdictional laws and regulations governing the service to be provided under the contract. Further, each contractor shall be responsible to obtain, at

WASHINGTON METROPOLITAN AREA TRANSIT AUTHORITY

SUPPLY AND SERVICE CONTRACT

IFB-FQ12235/CPR

its own cost and expense, any and all licenses/permits required to transact business in any political jurisdictions to be serviced.

19. PRIME CONTRACTOR DBE RESPONSIBILITIES

- a. If the contract value is over \$100,000, the prime contractor will be responsible for submitting a monthly report of the status of its DBE subcontractors as outlined in Appendix B.
- b. Reports shall be submitted monthly to the Authority Representative, who in turn, will forward a copy to the Office of Civil Rights, WMATA, Jackson Graham Building, 600 Fifth Street NW, Washington DC 20001.

20. FEDERAL/LOCAL/STATE SALES TAX

- a. Pursuant to Article XVI., Paragraph 78., of the Washington Area Metropolitan Transit Authority Compact, as adopted by the State of Maryland, the District of Columbia, and the Commonwealth of Virginia, with the authorization and consent of the Congress of the United States, the Authority has been accorded exemption from taxes as follows:

“the Authority and the Board shall not be required to pay taxes or assessments upon any of the property acquired by it or under its jurisdiction, control, possession or supervision, or upon its activities in the operation and maintenance of any transit facility or upon any revenues there from, and the property and income derived there from shall be exempted from all Federal, State, District of Columbia, municipal, and local taxation. This exemption shall include without limitation, all motor vehicle license fees, sales taxes and motor fuel taxes.”
- b. It has been the practice of the District of Columbia to apply the Authority's tax exempt status to certain purchases of materials required under Authority construction contracts and acquired by Contractor for physical incorporation into the project work. This has not been the practice in either Maryland or Virginia. The Authority does not represent or warrant that the District of Columbia practice applies to this project or, if it does, that it will continue in effect during the term of this project. It is the responsibility of the Contractor to determine its liability for any and all taxes applicable to this project. Assessment or payment of taxes by the Contractor, including taxes resulting from changes in existing laws or the application thereof or of new or additional taxes, shall not constitute the basis for an increase in the Contract price, except as otherwise allowed under Section 00779, FEDERAL, STATE AND LOCAL TAX.
- c. By submission of its bid, the proposer certifies that none of the taxes as to which the Authority is exempt are included in its bid price(s) or the final Contract Price. In the event that the Authority learns that any taxes to which the Authority is exempt are included in the final Contract Price, the Authority shall be entitled to a reduction in the Contract Price reflecting such amount and a refund of monies paid related to such taxes, plus applicable interest.

21. CONTRACTING OFFICERS TECHNICAL REPRESENTATIVE (COTR)

- a. The work will be conducted under the general direction of the Contracting Officer. Authority will be delegated to the Contracting Officer's Technical Representative (COTR) to take the following actions;
- (1) Act as the principal point of contact with the contractor. Submit a copy of each item of incoming correspondence and a copy of any enclosures to the Contract Administrator.
 - (2) Review and recommend approval/disapproval or modification of invoices and partial payment authorizations. Prepare the partial payment authorization as applicable, execute and forward to Accounting.
 - (3) Coordinate correspondence with the CA if its importance significantly impacts the contractual terms and obligations. Where such coordination is unnecessary provides an information copy to the CA.
 - (4) Provide the CA with information copies of any memorandum for record which is relative to the contract.
 - (5) Notify the Contracting Officer whenever the COTR has reason to believe that the estimated cost not-to-exceed amount will be exceeded.
 - (6) Prepare the Authority estimate for Proposed Contract Modifications. Participate in negotiations of modifications.
 - (7) Approve, in writing, the contractor's progress schedule when required.
 - (8) Receive from the contractor, monthly, if applicable, DBE status reports and forward them to the Office of Procurement and Materiels (PRMT), DBE Section.
 - (9) Provide the Contract Administrator with a written notification after all supplies/services have been received with statement that COTR is not aware of any open issues that would preclude closeout of the contract and that the Contract is ready for closeout. Return all records, correspondence, etc., to the Contract Administrator for closeout purposes.
 - (10) Provide the Contract Administrator with a written request (and requisition) to exercise option(s) [if any] a minimum of 90 days prior to the expiration of the base period of the contract.
- b. There are certain actions which are reserved for only the Contracting Officer. They are:
- (1) Approval of contract modification bids and/or other unilateral actions.
 - (2) Issuance of written orders to stop and/or resume work under Article 10, "Stop Work Orders", of the General Provisions.
 - (3) Negotiation with the Contractor for adjustment of contract price and/or time.
 - (4) The COTR is not authorized to render final decision under the DISPUTES article of the General Provisions.

WASHINGTON METROPOLITAN AREA TRANSIT AUTHORITY

SUPPLY AND SERVICE CONTRACT

IFB-FQ12235/CPR

(5) The COTR is not authorized to issue Termination Notices pursuant to the terms of this contract.

c. The presence or absence of the COTR or his inspectors shall not relieve the contractor from any requirements of the contract.

22. HAZARDOUS MATERIAL IDENTIFICATION AND MATERIAL SAFETY DATA

a. The Contractor agrees to submit a Material Safety Data Sheet (Department of Labor Form OSHA-20), as prescribed in Federal Standard No. 313B, for all hazardous material 5 days before delivery of the material, whether or not listed in Appendix A of the Standard. This obligation applies to all materials delivered under this contract which involve exposure to hazardous materials or items containing these materials.

b. "Hazardous material," as used in this clause, is as defined in Federal Standard No. 313B, in effect on the date of this contract.

c. Neither the requirements of this clause nor any act or failure to act by the Authority shall relieve the Contractor of any responsibility or liability for the safety of Authority, Contractor, or subcontractor personnel or property.

d. Nothing contained in this clause shall relieve the Contractor from complying with applicable Federal, state, and local laws, codes, ordinances, and regulations (including the obtaining of licenses and permits) in connection with hazardous material.

e. The Authority's rights in data furnished under this contract with respect to hazardous material are as follows:

(1) To use, duplicate and disclose any data to which this clause is applicable. The purposes of this right are to (i) apprise personnel of the hazards to which they may be exposed in using, handling, packaging, transporting, or disposing of hazardous material (ii) obtain medical treatment for those affected by the material; and (iii) have others use, duplicate, and disclose the data for the Authority for these purposes.

(2) To use, duplicate, and disclose data furnished under this clause, in accordance with subparagraph (e)(1) above, in precedence over any other clause of this contract providing for rights in data.

(3) That the Authority is not precluded from using similar or identical data acquired from other sources.

(4) That the data shall not be duplicated, disclosed, or released outside the Authority, in whole or in part for any acquisition or manufacturing purpose, if the following legend is marked on each piece of data to which this clause applies -

WASHINGTON METROPOLITAN AREA TRANSIT AUTHORITY

SUPPLY AND SERVICE CONTRACT

IFB-FQ12235/CPR

"This is furnished under Authority Contract No. _____ and shall not be used, duplicated, or disclosed for any acquisition or manufacturing purpose without the permission of This legend shall be marked on any reproduction of this data."

(End of legend)

(5) That the Contractor shall not place the legend or any other restrictive legend on any data which (i) the Contractor or any subcontractor previously delivered to the Authority without limitations or (ii) should be delivered without limitations under the conditions specified in the clause Rights in Technical Data.

f. The Contractor shall insert this clause, including this paragraph with appropriate changes in the designation of the parties, in subcontracts at any tier (including purchase designations or purchase orders) under this contract involving hazardous material.

23. DELIVERY/HANDING INSTRUCTIONS

a. Delivery of Rail Fasteners will be to a storage site in the Washington DC area as designated by WMATA. The storage site will be furnished by WMATA. Shipment shall take place 60 days after Notice to Proceed (NTP).

b. The successful bidder shall deliver Rail Fasteners via truck to the designated WMATA location between the hours of 8:00 AM and 3:00 PM, Monday through Friday.

c. In addition, a 48 hour notice must be given to WMATA prior to each delivery.

d. Delivery locations:

Location A

WMATA Storage Facility
6851 Industrial Road
Springfield, Va. 22151

Location B

WMATA Metro Rail Facility
4301 Auth Place
Suitland, Md. 20746

24. PACKAGING AND HANDING INSTRUCTIONS

Rail Fastener bodies shall be packed in waterproof and weatherproof containers banded on pallets for forklift handling. Rail clips and rail anchor assemblies shall be packed in separate water proof and weatherproof containers, banded on pallets for forklift handling. Clearly mark each container with identification of the item contained, supplier's name, shipping date, number of pieces, destination, and gross weight.

25. FIRST ARTICLE

a. If required by the technical specifications, the Contractor shall deliver one (1) unit to the Authority for first article (pre-production sample) tests. The shipping documentation shall contain this contract number and the Lot/Item identification. The Characteristics that the first article must meet and the testing requirements are specified elsewhere in this contract.

WASHINGTON METROPOLITAN AREA TRANSIT AUTHORITY

SUPPLY AND SERVICE CONTRACT

IFB-FQ12235/CPR

- b. Within 10 days after the Authority receives the first article, the Contracting Officer shall notify the Contractor, in writing, of the conditional approval, approval, or disapproval of the first article. The notice of conditional approval or approval shall not relieve the Contractor from complying with all requirements of the specifications and all other terms and conditions of this contract. A notice of conditional approval shall state any further action required of the Contractor. A notice of disapproval shall cite the reasons for the disapproval.
- c. If the first article is disapproved, the Contractor, upon Authority request, shall submit an additional first article for testing. After each request, the Contractor shall make any necessary changes, modifications, or repairs to the first article or select another first article for testing. All costs related to these tests are to be borne by the Contractor, including any and all costs for additional test following a disapproval. The Contractor shall furnish any additional first article to the Authority under the terms and conditions and within the time specified by the Authority. The Authority shall act on this first article within the time limit specified in paragraph (b) above. The Authority reserves the right to require an equitable adjustment of the contract price for any extension of the delivery schedule or for any additional costs to the Authority related to these tests.
- d. If the Contractor fails to deliver any first article on time, or the Contracting Officer disapproves any first article, the Contractor shall be deemed to have failed to make delivery within the meaning of the Defaults clause of this contract.
- e. Unless otherwise provided in the contract, the Contractor—
 - (1) May deliver the approved first article as a part of the contract quantity, provided it meets all contract requirements for acceptance and was not consumed or destroyed in testing; and
 - (2) Shall remove and dispose of any first article from the Authority test facility at the Contractor's expense.
- f. If the Authority does not act within the time specified in paragraph (b) or (c) above, the Contracting Officer shall, upon timely written request from the Contractor, equitably adjust under the Changes clause of this contract the delivery or performance dates and/or the contract price, and any other contractual term affected by the delay.
- g. The Contractor is responsible for providing operating and maintenance instructions, spare parts support, and repair of the first article during any first article test.
- h. Before first article approval, the acquisition of materials or components for, or the commencement of production of, the balance of the contract quantity is at the sole risk of the Contractor. Before first article approval, the costs thereof shall not be allocable to this contract for (1) progress payments, or (2) termination settlements if the contract is terminated for the convenience of the Authority.
- i. The COTR will inspect the first article (pre-production sample) against the specification and shop drawings as well as test its fit in the field. A written report will be forwarded to the contractor in accordance with (b) above.

26. RIGHTS IN TECHNICAL DATA - UNLIMITED

Not Used.

27. ORGANIZATIONAL CONFLICT OF INTEREST

Unless specifically exempted from the conditions of this provision by the Contracting Officer, any Authority contractor, subcontractor, subsidiary, or other entity which is legally related and which develops or drafts specifications, requirements, statement of work, invitation for bids, will be excluded from competing for the directly ensuing procurement.

28. LIVING WAGE

This contract is subject to the Authority's Living Wage Policy and implementing regulations. The Living Wage provision is required in all contracts for services (including construction) awarded in an amount that exceeds \$100,000 in a 12-month period.

- (a) The Authority's Living Wage Rate is \$12.89 per hour, and may be reduced by the contractor's per-employee cost for health insurance.
- (b) The Contractor shall:
 - (1) Pay the Authority's Living Wage Rate, effective during the time the work is performed, to all employees who perform work under this contract;
 - (2) Include the Living Wage clause in all subcontracts that exceed \$15,000 in a 12 month period awarded under this contract;
 - (3) Maintain payroll records, in accordance with the retention and examination of records requirements in the General Provisions, and shall include a similar provision in affected subcontracts that requires the subcontractor to maintain its payroll records for the same length of time; and
 - (4) Certify with each monthly invoice that the Authority Living Wage Rate was paid to affected employees, or if applicable, certify prior to contract award or contract extension, if any, that one or more of the exemptions in paragraph (d) below applies.
- (c) The Contractor shall not split or subdivide a contract, pay an employee through a third party, or treat an employee as a subcontractor or independent contractor to avoid compliance with the Living Wage provisions.
- (d) Exemptions to the Living Wage provisions include:
 - (1) Contracts and agreements subject to higher wage rates required federal law or collective bargaining agreements;
 - (2) Contracts or agreements for regulated utilities;
 - (3) Emergency services to prevent or respond to a disaster or imminent threat to public health and safety;
 - (4) Contractor employees who work less than full-time; and
 - (5) Contractors who employ fewer than ten employees.

WASHINGTON METROPOLITAN AREA TRANSIT AUTHORITY

SUPPLY AND SERVICE CONTRACT

IFB-FQ12235/CPR

- (e) The Authority may adjust the Living Wage Rate effective in January of each year. The adjustment will reflect the average Living Wage Rate among Metro's Compact Jurisdictions with Living Wage provisions. If after contract award the living wage rate increases, the Contractor is entitled to an equitable adjustment to the rate in the amount of the increase for employees who are affected by the escalated wage.
- (f) Failure to comply with the Authority's Living Wage provisions shall result in the Authority's right to exercise available contract remedies, including contract termination or debarment from future contracts.

29. BUY AMERICA ACT

- a SURFACE TRANSPORTATION ASSISTANCE ACT OF 1982, BUY AMERICA, SECTION 165
 - i. Notwithstanding any other provision of law, the Secretary of Transportation shall not obligate any funds authorized to be appropriated by this Act or by any Act amended by this Act or, after the date of enactment of this Act, any funds authorized to be appropriated to carry out this Act, Title 23, United States Code, the Urban Mass Transportation Act of 1964, or the Surface Transportation Assistance Act of 1978 and administered by the Department of Transportation, unless steel and manufactured products used in such project are produced in the United States.
 - ii. The provisions of subsection (1) of this section shall not apply where the Secretary finds
 - (1) that their application would be inconsistent with the public interest;
 - (2) that such materials and products are not produced in the United States in sufficient and reasonably available quantities and of a satisfactory quality;
 - (3) in the case of the procurement of bus and other rolling stock (including train control, communication, and traction power equipment) under the Urban Mass Transportation Act of 1964, that
 - (a) the cost of components and sub-components which are produced in the United States is more than 60 per cent of the cost of all components and sub-components of the vehicle or equipment described in this paragraph, and
 - (b) final assembly of the vehicle or equipment described in this paragraph has taken place in the United States;
 - (4) that inclusion of domestic material will increase the cost of the overall project contract by more than 25 per cent.

WASHINGTON METROPOLITAN AREA TRANSIT AUTHORITY

SUPPLY AND SERVICE CONTRACT

IFB-FQ12235/CPR

- iii. For purposes of this section, in calculating components' cost, labor costs involved in final assembly shall not be included in the calculation.
 - iv. The Secretary of Transportation shall not impose any limitation or condition on assistance provided under this Act, the Urban Mass Transportation Act of 1964, the Surface Transportation Assistance Act of 1978, or Title 23, United States Code, which restricts any State from imposing more stringent requirements than this section on the use of articles, materials, and supplies mined, produced, or manufactured in foreign countries in projects carried out with such assistance or restricts any recipient of such assistance from complying with such State imposed requirements.
 - v. Section 401 of the Surface Transportation Assistance Act of 1978 is repealed.
- b. The regulations implementing the Buy America Act set forth in 49 CFR Part 661 are hereby incorporated by reference into the provisions of this article of the Contract.

30. SITE VISIT/INSPECTION

Not Used.

31. GARNISHMENT OF PAYMENTS

Payment under this contract shall be subject to any garnishment and attachment orders issued pursuant to the laws of Maryland, Virginia, and the District of Columbia, and to levies under the laws of the United States.

32. FORCE MAJEURE CLAUSE

The Contractor's right to proceed shall not be so terminated nor the Contractor charged with resulting damage under the following circumstances:

- a. If the delay in performing this work arises from unforeseeable causes beyond the control and without the fault or negligence of the Contractor, including, but not restricted to, acts of God, acts of the public enemy, acts of the Authority in its contractual capacity, fires, floods, epidemics, quarantine restrictions, strikes, freight embargoes, unusually severe weather, or delays of subcontractors or suppliers at any tier arising from causes other than normal weather beyond the control and without the fault or negligence of both the Contractor and such subcontractors or suppliers.
- b. The rights and remedies of the Authority provided in this Section are in addition to any other rights and remedies provided by law or under this Contract.

33. MULTI YEAR CONTRACTS

Not Used

36. METRIC SYSTEM

To the extent U.S. DOT or FTA directs, the Contractor agrees to use the metric system of measurement in its Project activities, in accordance with the Metric Conversion Act, as amended by the Omnibus Trade and Competitiveness Act, 15 U.S.C. 205a et seq; Executive Order No. 12770, "Metric Usage in Federal Government Programs," 15 U.S.C. 205a note; and applicable U.S. DOT or FTA regulations in accordance with applicable Federal directives. As practicable and feasible, the Contractor agrees to supply products and services with dimensions expressed in the metric system of measurement. Metric usage shall not be required to the extent that such use is impractical or is likely to cause significant inefficiencies or loss of markets to United States firms.

37. NOTIFICATION OF FEDERAL PARTICIPATION

This project is being funded in whole or part with Federal funds.

38. WHISTLEBLOWER PROTECTION

- a. The Contractor and its subcontractors shall encourage their employees and independent contractors to report information—without fear of actual or threatened discrimination, retaliation or reprisal—that they in good faith reasonably believe is evidence of gross mismanagement; gross misuse or waste of public resources or funds; fraud; violation of law; abuse of authority in connection with the conduct of Metro operations or contracts; or a substantial and specific danger to health, security or safety. The Contractor and its subcontractors shall notify their employees that they may make reports under this paragraph to:
- (1) WMATA's Office of Inspector General (OIG), in person, in writing, through the OIG Hotline (202-962-2400) or email hotline.oig@wmata.com or by any other reasonable means;
 - (2) WMATA's Metro Transit Policy Department (MTPD), in person, by telephone (202-962-2121) or by any other reasonable means, or to the OIG, if the information constitutes a potential violation of criminal law;
 - (3) WMATA's Chief Safety Officer, in person, in writing, through the SAFE Hotline (202-249-7233) or email safety@wmata.com, or by any other reasonable means; or
 - (4) Any other official, office or agency within WMATA or outside WMATA that the employee or independent contractor reasonably believes has the authority to act on the matter.
- b. The Contractor, its employees, independent contractors and subcontractors shall cooperate with any inquiry or review by an authorized official of WMATA, or by the federal government or any other governmental entity with jurisdiction over WMATA, regarding a matter that would constitute a report under paragraph (a) or a violation of this or any whistleblower provision of this Contract, and with any enforcement or judicial proceeding arising from such inquiry or review.
- c. The Contractor and its subcontractors shall not interfere with or deny the right of any

WASHINGTON METROPOLITAN AREA TRANSIT AUTHORITY

SUPPLY AND SERVICE CONTRACT

IFB-FQ12235/CPR

employee or independent contractor of either the Contractor or any of its subcontractors to make a report under paragraph (a). The Contractor and its subcontractors shall not recommend, take or threaten to take any action having a negative or adverse impact on any employee or independent contractor of either the Contractor or any of its subcontractors because he or she:

- (1) made or is perceived to have made a report under paragraph (a);
 - (2) sought a remedy under applicable law after making a report under paragraph (a);
 - (3) participated in or cooperated with an inquiry or review by an authorized official of Metro, or by the federal government or any other governmental entity with jurisdiction over Metro, regarding a matter that would constitute a report under paragraph (a) or a violation of this or any whistleblower provision of this Contract, or with an enforcement or judicial proceeding arising from such inquiry or review;
 - (4) refused to obey an order that would violate law; or
 - (5) refused to work or authorize work when a hazardous safety or security condition presents an imminent danger of death or serious injury, there was no reasonable alternative to refusal, there was not sufficient time to eliminate the danger in absence of refusal and the individual, where possible, notified the Contractor or subcontractor of the condition and of the intent not to perform or authorize work.
- d. The Contractor shall include, or shall cause to be included, the substance of this section, including this paragraph (d), in its subcontracts at all tiers.
- e. The Contractor and its subcontractors shall comply with the National Transit Systems Security Act (NTSSA), which prohibits discharging, demoting, suspending, reprimanding or in any other way discriminating against an employee as a reprisal for the employee lawfully and in good faith—
- (1) reporting a hazardous safety or security condition;
 - (2) refusing to work when a hazardous safety or security condition presents an imminent danger of death or serious injury, there is no reasonable alternative to refusal, there is not sufficient time to eliminate the danger in absence of refusal and the individual, where possible, has notified the Contractor or subcontractor of the condition and of the intent to not perform work;
 - (3) refusing to authorize the use of any safety or security related equipment, track or structures, if the individual is responsible for their inspection or repair and reasonably believes they are in a hazardous safety or security condition, there is no reasonable alternative to refusal, there is not sufficient time to eliminate the danger in absence of refusal and the individual, where possible, has notified the Contractor or subcontractor of the condition and of the intent not to authorize use of hazardous equipment or infrastructure unless corrected;

WASHINGTON METROPOLITAN AREA TRANSIT AUTHORITY

SUPPLY AND SERVICE CONTRACT

IFB-FQ12235/CPR

- (4) providing information for or directly assisting in an investigation of conduct that the individual reasonably believes to be in violation of federal law regarding safety, security or fraud, waste or abuse of funds intended for safety or security;
 - (5) refusing to violate or assist in violation of federal public transportation safety or security law;
 - (6) cooperating with a safety or security investigation by the U.S. Secretary of Transportation, U.S. Secretary of Homeland Security or the National Transportation Safety Board;
 - (7) furnishing information to law enforcement agencies relating to an accident or incident resulting in damage to property, injury or death; or
 - (8) filing a complaint under the NTSSA or testifying regarding such complaint.
- f. The contractor shall notify the Authority of any instance, related to this Contract, of a report under paragraph (a)(1) or refusal under paragraphs (a)(2), (3) or (5).
 - g. The enforcement, filing and investigation of complaints, and remedies under this section shall be governed by the NTSSA, applicable federal regulations and federal law.
 - h. This section shall be interpreted in accordance with the NTSSA. If any provision is found to be in conflict with the NTSSA, the NTSSA shall govern.
 - i. The Contractor shall include, or shall cause to be included, the substance of this section, including this paragraph (e), in its subcontracts at all tiers.

39. DRUG AND ALCOHOL TESTING

Contractors who perform safety-sensitive functions shall be subject to compliance with a drug and alcohol testing program according to Federal guidelines published in FTA regulations (49 CFR Part 655).

40. DAVIS-BACON AND COPELAND ANTI-KICKBACK ACTS

Not Used

WASHINGTON METROPOLITAN AREA TRANSIT AUTHORITY

SUPPLY AND SERVICE CONTRACT

IFB-FQ12235/CPR

METROPOLITAN WASHINGTON COUNCIL OF GOVERNMENTS RIDER CLAUSE

USE OF CONTRACT(S) BY MEMBERS COMPRISING THE METROPOLITAN WASHINGTON COUNCIL OF GOVERNMENTS PURCHASING OFFICERS' COMMITTEE.

- A. If authorized by the bidder(s), resultant contract(s) will be extended to any or all of the listed members as designated by the bidder to purchase at contract prices in accordance with contract terms.

- B. Any member utilizing such contract(s) will place its own order(s) directly with the successful contractor. There shall be no obligation on the part of any participating member to utilize the contract(s).

- C. A negative reply will not adversely affect consideration of your bid/proposal.

- D. It is the awarded vendor's responsibility to notify the members shown below of the availability of the Contract(s).

- E. Each participating jurisdiction has the option of executing a separate contract with the awardee. Contracts entered into with a participating jurisdiction may contain general terms and conditions unique to that jurisdiction including, by way of illustration and not limitation, clauses covering minority participation, non-discrimination, indemnification, naming the jurisdiction as an additional insured under any required Comprehensive General Liability policies, and venue. If, when preparing such a contract, the general terms and conditions of a jurisdiction are unacceptable to the awardee, the awardee may withdraw its extension of the award to that jurisdiction.

- F. The issuing jurisdiction shall not be held liable for any costs or damages incurred by another jurisdiction as a result of any award extended to that jurisdiction by the awardee.

BIDDER'S AUTHORIZATION TO EXTEND CONTRACT:

YES NO JURISDICTION

- Alexandria, Virginia
- Alexandria Public Schools
- Alexandria Sanitation Authority
- Arlington County, Virginia
- Arlington County Public Schools
- Bladensburg, Maryland
- Bowie, Maryland
- Charles County Public Schools
- College Park, Maryland
- Culpeper County, Virginia

YES NO JURISDICTION

- Gaithersburg, Maryland
- Greenbelt, Maryland
- Herndon, Virginia
- Leesburg, Virginia
- Loudoun County, Virginia
- Loudoun County Public Schools
- Loudoun County Sanitation Authority
- Manassas, Virginia
- City of Manassas Public Schools
- Manassas Park, Virginia

WASHINGTON METROPOLITAN AREA TRANSIT AUTHORITY

SUPPLY AND SERVICE CONTRACT

IFB-FQ12235/CPR

- | | |
|---|--|
| <input type="checkbox"/> District of Columbia | <input type="checkbox"/> Maryland-National Capital Park & Planning Comm. |
| <input type="checkbox"/> District of Columbia Courts | <input type="checkbox"/> Metropolitan Washington Airports Authority |
| <input type="checkbox"/> District of Columbia Public Schools | <input type="checkbox"/> Metropolitan Washington Council of Governments |
| <input type="checkbox"/> District of Columbia Water & Sewer Auth. | <input type="checkbox"/> Montgomery College |
| <input type="checkbox"/> Fairfax, Virginia | <input type="checkbox"/> Montgomery County, Maryland |
| <input type="checkbox"/> Fairfax County, Virginia | <input type="checkbox"/> Montgomery County Public Schools |
| <input type="checkbox"/> Fairfax County Water Authority | <input type="checkbox"/> Northern Virginia Community College |
| <input type="checkbox"/> Falls Church, Virginia | <input type="checkbox"/> OmniRide |
| <input type="checkbox"/> Fauquier County Schools & Government, Virginia | <input type="checkbox"/> Potomac & Rappahannock Trans. Comm. |
| <input type="checkbox"/> Frederick, Maryland | <input type="checkbox"/> Prince George's County, Maryland |
| <input type="checkbox"/> Frederick County, Maryland | |

YES NO JURISDICTION

- Prince George's Public Schools
- Prince William County, Virginia
- Prince William County Public Schools
- Prince William County Service Authority
- Rockville, Maryland
- Spotsylvania County Schools
- Stafford County, Virginia
- Takoma Park, Maryland
- Upper Occoquan Sewage Authority
- Vienna, Virginia
- Virginia Railway Express
- Washington Metropolitan Area Transit Authority
- Washington Suburban Sanitary Commission
- Winchester, Virginia
- Winchester Public Schools

Vendor Name

PART III
TECHNICAL SPECIFICATIONS

**TECHNICAL SPECIFICATIONS
Direct Fixation Rail Fasteners**

Please see Attachment 1

APPENDIX B

ATTACHMENT A

***NOTICE OF REQUIREMENTS
FOR
DISADVANTAGED BUSINESS ENTERPRISE (DBE)***

March 2012

~Applies only if bid/proposal price is \$500,000 or more for a construction contract or \$100,000 or more for a supply and service contract.

WASHINGTON METROPOLITAN AREA TRANSIT AUTHORITY

SUPPLY AND SERVICE CONTRACT

IFB-FQ12235/CPR

~APPENDIX B~

DISADVANTAGED BUSINESS ENTERPRISE (DBE)

1. DISADVANTAGED BUSINESS ENTERPRISE (DBE) REQUIREMENT:

A. The DBE requirements of the Authority's DBE Program Plan apply to this contract. Accordingly, the Contractor shall carry out the requirements of the Authority's DBE Program Plan and this Appendix in the award and administration of this U.S. Department of Transportation (US DOT) assisted contract.

2. POLICY:

A. It is the policy of the Authority (WMATA), the Federal Transit Administration (FTA) and the US DOT that Disadvantaged Business Enterprises (DBEs) shall compete fairly to receive and participate in performing federally assisted contracts, including contracts and subcontracts at any tier. It is further the policy of the Authority, the FTA and the US DOT that its prime contractors establish procedures to ensure the timely payment of amounts due pursuant to the terms of their subcontracts. The Contractor hereby agrees to carry out this policy in the award and administration of subcontracts to the fullest extent possible consistent with efficient Contract performance.

3. CONTRACT GOAL:

A. If the bidder/proposer is not a DBE, the bidder/proposer agrees that the DBE goal for this Contract shall be met by subcontractors or by joint ventures with DBEs. The goal set forth for this **Contract is _____%** of the final Contract price, including amendment and modification. The amount of DBE participation will be determined by the dollar value of the work performed and/or supplies furnished by DBE firms as compared to the total value of all work performed and/or supplies furnished under this Contract. The Contractor shall have met this goal if the Contractor's DBE participation meets or exceeds this goal.

B. In cases where work is added to the Contract by modification such that additional DBE participation is necessary to meet this goal, the Contractor shall increase the participation of one or more firms listed on the "Schedule of DBE Participation" or submit additional DBE certified firms to meet the goal. In cases where work is deleted from the Contract, the goal shall be applicable to the new Contract amount. The Contractor shall be permitted to meet the goal by revising its DBE participation, provided, however, that the revision shall not result in DBE participation that is less than the original goal.

4. DEFINITIONS:

A. **Appendix B.** The Notice of Requirements for Disadvantaged Business Enterprise, which when attached to a solicitation, implements the DBE

WASHINGTON METROPOLITAN AREA TRANSIT AUTHORITY

SUPPLY AND SERVICE CONTRACT

IFB-FQ12235/CPR

requirements of the Authority's DBE Program Plan in the award and administration of federally funded Authority contracts.

- B. **Certified DBE.** means a for-profit small business concern (a) that is at least 51 percent owned by one or more individuals who are both socially and economically disadvantaged or, in the case of a corporation, in which 51 percent of the stock is owned by one or more such individuals; (b) whose management and daily business operations are controlled by one or more of the socially and economically disadvantaged individuals who own it; and (c) whose eligibility is evidenced by a current WMATA Certification letter, a D.C. Department of Transportation Certification letter, or a certification letter issued by the Metropolitan Washington Unified Certification Program (MWUCP).
- C. **Contractor.** One who participates, through a contract or subcontract (at any tier), in a US DOT assisted highway, transit or airport program.
- D. **DC DOT.** The District of Columbia Department of Transportation.
- F. **Good Faith Efforts.** Efforts to achieve a DBE goal or other requirements of the Authority's DBE Program Plan which by their scope, intensity, and appropriateness to the objective, can reasonably be expected to fulfill the goal program requirement.
- G. **Joint Venture.** An association of a DBE firm and one or more other firms to carry out a single, for-profit business enterprise, for which the parties combine their property, capital, efforts, skills and knowledge, and in which the DBE is responsible for a distinct, clearly defined portion of the work of the contract and shares in the capital contribution, control, management, risks, and profits of the joint venture commensurate with its ownership interest.
- H. **Metropolitan Washington Unified Certification Program (MWUCP).** A unified certification program mandated by 49 CFR §26.81 between two federal transit recipients (WMATA and the D.C. Department of Transportation). The agreement became effective January 2005.
- I. **Pre-certification.** A requirement under 49 CFR §26.81(c) that all certifications by the MWUCP be made final before the due date for bids or offers on a contract on which a firm seeks to participate as a DBE.
- J. **Race-conscious.** A measure or program that is focused specifically on assisting only DBEs, including women-owned DBEs.
- K. **Race-neutral.** A measure or program that is, or can be, used to assist all small businesses. For the purposes of the DBE program, race-neutral includes gender-neutrality.
- L. **Small Business Concern.** With respect to firms seeking to participate as DBE's in US DOT assisted contracts, a small business concern as defined pursuant to Section 3 of the Small Business Act and Small Business Administration

WASHINGTON METROPOLITAN AREA TRANSIT AUTHORITY

SUPPLY AND SERVICE CONTRACT

IFB-FQ12235/CPR

implementing regulations (13 CFR Part 121) that also does not exceed the cap on average annual gross receipts specified in 49 CFR Part 26.65(b).

- M. **Socially and Economically Disadvantaged Individual.** Any individual who is a citizen (or other lawfully admitted permanent resident) of the United States and who the Authority finds to be a socially and economically disadvantaged individual on a case-by-case basis, and any individual in the following groups, members of which are rebuttably presumed to be socially and economically disadvantaged.
- (1) Black Americans, which includes persons having origins in any of the Black racial groups of Africa;
 - (2) Hispanic Americans, which includes persons of Mexican, Puerto Rican, Cuban, Dominican, Central or South American, or other Spanish or Portuguese culture or origin, regardless of race;
 - (3) Native Americans, which includes persons who are American Indians, Eskimos, Aleuts, or Native Hawaiians;
 - (4) Asian-Pacific Americans, which includes persons whose origins are from Japan, China, Taiwan, Korea, Burma (Myanmar), Vietnam, Laos, Cambodia (Kampuchea), Thailand, Malaysia, Indonesia, the Philippines, Brunei, Samoa, Guam, the U.S. Trust Territories of the Pacific Islands (Republic of Palau), the Commonwealth of the North Marianas Islands, Macao, Fiji, Tonga, Kiribati, Juvalu, Nauru, Federated States of Micronesia, or Hong Kong;
 - (5) Subcontinent Asian Americans, which includes persons whose origins are from India, Pakistan, Bangladesh, Bhutan, the Maldives Islands, Nepal or Sri Lanka;
 - (6) Women; and
 - (7) Any additional groups whose members are designated as socially and economically disadvantaged by the SBA, at such time as the SBA designation becomes effective.
- N. US DOT Assisted Contract. Any contract between the Authority and a contractor (at any tier) funded in whole or in part with US DOT financial assistance, including letters of credit or loan guarantees.
- O. Unified Certification Program (UCP). The program mandated by 49 CFR Part 26.81(a), which requires all U. S. DOT recipients of federal financial assistance to participate in a statewide certification program by March 2002.
- P. WMATA. Washington Metropolitan Area Transit Authority, the transit system (rail and bus) serving the metropolitan Washington area, including parts of Virginia and Maryland.

5. HOW DBE PARTICIPATION IS COUNTED TOWARDS THE CONTRACT GOAL:

DBE participation shall be counted towards meeting the DBE goal in accordance with the following:

- A. When a DBE participates in a contract, only the value of the work actually performed by the DBE is counted towards the DBE goal.
 - (1) This amount includes the entire amount of that portion of a construction contract that is performed by the DBE's own forces. This amount includes the cost of supplies and materials obtained by the DBE for the work of the contract, including supplies purchased or equipment leased by the DBE (except supplies and equipment the DBE subcontractor purchases or leases from the prime contractor or its affiliate).
 - (2) This amount includes the entire amount of fees or commissions charged by a DBE firm for providing a bona fide service, such as professional, technical, consultant, or managerial services, or for providing bonds or insurance specifically required for the performance of the contract, towards the DBE goal, provided the fee is reasonable and not excessive as compared with fees customarily allowed for similar services.
 - (3) When a DBE subcontracts part of its work under the contract to another firm, the value of the subcontract work may be counted towards the DBE goal only if the DBE's subcontractor is itself a DBE. Work that a DBE subcontracts to a non-DBE firm does not count towards the DBE goal.
- B. When a DBE performs as a participant in a joint venture, the portion of the total dollar value of the contract equal to the distinct, clearly defined portion of the work of the contract that a DBE performs with its own forces towards the DBE goal may be counted.
- C. Expenditures to a DBE contractor towards the DBE goal may be counted only if the DBE is performing a commercially useful function on that contract.
 - (1) A DBE performs a commercially useful function when it is responsible for execution of the work of the contract and is carrying out its responsibilities by actually performing, managing, and supervising the work involved. To perform a commercially useful function, the DBE must also be responsible, with respect to materials and supplies used on the contract, for negotiating price, determining quality and quantity, ordering the material, and installing (where applicable) and paying for the material itself. To determine whether a DBE is performing a commercially useful function, the Authority will consider the amount of work subcontracted, industry practices, whether the amount the firm is to be paid under the contract is commensurate with the work it is actually performing and the DBE credit claimed for its performance of the work, and other relevant factors.

WASHINGTON METROPOLITAN AREA TRANSIT AUTHORITY

SUPPLY AND SERVICE CONTRACT

IFB-FQ12235/CPR

- (2) A DBE does not perform a commercially useful function if its role is limited to that of an extra participant in a transaction, contract, or project through which funds are passed in order to obtain the appearance of DBE participation.
 - (3) If a DBE does not perform or exercise responsibility for at least 30 percent of the total cost of its contract with its own work force, or if the DBE subcontracts a greater portion of the work of a contract than would be expected on the basis of normal industry practice for the type of work, the Authority will presume that the DBE is not performing a commercially useful function.
- D. The following factors will be used by the Authority in determining whether a DBE trucking company is performing a commercial useful function:
- (1) The DBE must be responsible for the management and supervision of the entire trucking operation for which it is responsible for on a particular contract, and there cannot be a contrived arrangement for the purpose of meeting the DBE goal.
 - (2) The DBE must itself own and operate at least one fully licensed, insured and operational truck used on the contract.
 - (3) The DBE receives credit for the total value of the transportation services it provides on the contract using trucks it owns, insures, and operates using drivers, it employs.
 - (4) The DBE may lease trucks from another DBE firm, including an owner-operator who is certified as a DBE. The DBE who leases trucks from another DBE receives credit for the total value of the transportation services the lessee DBE provides on the contract.
 - (5) The DBE may also lease trucks from a non-DBE firm, including an owner-operator. The DBE who leases trucks from a non-DBE is entitled to credit only for the fee or commission it receives as a result of the lease arrangement. The DBE does not receive credit for the total value of the transportation services provided by the lessee, since these services are not provided by a DBE.
 - (6) The lease must indicate that the DBE has exclusive use of and control over the truck. This does not preclude the leased truck from working for others during the terms of the lease with the consent of the DBE, so long as the lease gives the DBE absolute priority for use of the leased truck. Leased trucks must display the name and identification number of the DBE.
- E. The following factors will be used to count expenditures with DBEs for materials or supplies towards the DBE goal:

WASHINGTON METROPOLITAN AREA TRANSIT AUTHORITY

SUPPLY AND SERVICE CONTRACT

IFB-FQ12235/CPR

- (1) If the materials or supplies are obtained from a DBE manufacturer, 100 percent of the cost of the materials or supplies will be counted towards the DBE goal. A manufacturer is a firm that operates or maintains a factory or establishment that produces, on the premises, the materials, supplies, articles, or equipment required under the contract and of the general character described by the contract.
 - (2) If the materials or supplies are purchased from a DBE regular dealer, 60 percent of the cost of the materials or supplies will be counted towards the DBE goal. A regular dealer is a firm that owns, operates or maintains a store, warehouse, or other establishment in which the materials, supplies, articles or equipment of the general character described and required under the contract are bought, kept in stock, and regularly sold or leased to the public in the usual course of business. To be a regular dealer, the firm must be an established, regular business that engages, as its principal business and under its own name, in the purchase and sale or lease of the products in question. A person may be a regular dealer in such bulk items as petroleum products, steel, cement, gravel, stone or asphalt without owning, operating, or maintaining a place of business as provided in this paragraph if this person both owns and operates distribution equipment for the products. Any supplementing of regular dealers' own distribution equipment shall be by long-term lease agreement and not on an ad hoc or contract-by-contract basis. Packagers, brokers, manufacturers' representatives, or other persons who arrange or expedite transactions are not regular dealers within the meaning of this paragraph.
 - (3) With respect to materials or supplies purchased from a DBE which is neither a manufacturer nor a regular dealer, the entire amount of fees or commissions charged for assistance in the procurement of the materials and supplies, or fees or transportation charges for the delivery of materials and supplies required on a job site, may be counted towards the DBE goal, provided the fees are reasonable and are not excessive as compared with fees customarily allowed for similar services. The cost of the materials and supplies themselves may not be counted towards the DBE goal.
- F. All DBE firms must be pre-certified. Participation by a firm that is not currently certified as a DBE by the Authority at the time of the due date for bids or offers on a contract, does not count towards the DBE goal. All DBE firms must be in compliance with 49 CFR, Part 26.
- G. The dollar value of work performed under the contract by a firm who has been decertified as a DBE by the MWUCP does not count towards the DBE goal.
- H. The participation of a DBE subcontractor does not count towards the Contractor's DBE goal until the amount being counted towards the goal has been paid to the DBE.

6. BID AND PROPOSAL REQUIREMENTS (WITH THE BID/PROPOSAL):

WASHINGTON METROPOLITAN AREA TRANSIT AUTHORITY

SUPPLY AND SERVICE CONTRACT

IFB-FQ12235/CPR

The bidder/proposer shall submit the following with its bid/proposal. Any bidder/proposer who fails to complete and return this information with its bid/proposal shall be deemed to be not responsive and may be ineligible for contract award. Bidders/proposers that fail to meet the DBE goal above and fail to demonstrate "good faith efforts" to justify waiver of the DBE goal (see paragraph 6.C. below) shall be deemed to be not responsible and will be ineligible for Contract award.

- A. Completed "Schedule of DBE Participation" (Attachment B-1) sufficient to meet the above goal. If the bidder/proposer is a DBE firm and intends to satisfy the appropriate DBE requirement with its own firm, it must indicate in the Schedule the area of work and percentage it will perform to satisfy the goal. All bidder/proposers must attach current WMATA, DC DOT or MWUCP certification letters for each DBE listed on the Schedule.
- B. Executed "Letters of Intent to Perform as a Subcontractor/Joint Venture" (Attachment B-2). If the bidder/proposer is not a DBE or intends to satisfy the requirements through other DBE firms, then it must attach these letters from each certified DBE listed on the Schedule.
- C. Justification for grant of relief (Appendix B waiver of DBE goal). If in the submittal of its bid/proposal, the bidder/proposer fails to meet the DBE goal above, the bidder/proposer has the burden of furnishing sufficient documentation with its bid/proposal of its "good faith efforts" to justify a grant of relief (waiver) from the goal or portion of the goal. Such justification shall be in the form of a detailed report. The following is a list of actions which shall be considered as part of the bidder's/proposer's good faith efforts to obtain DBE participation. This list is neither a mandatory checklist nor is it intended to be exclusive or exhaustive. Other factors or types of efforts may be relevant in appropriate cases:
 - (1) Soliciting through all reasonable and available means (e.g. attendance at pre-bid/proposal meetings, advertising and/or written notices) the interest of all certified DBEs who have the capability to perform the work of the contract. The bidder/proposer must solicit this interest within sufficient time to allow the DBEs to respond to the solicitation. The bidder/proposer must determine with certainty if the DBEs are interested by taking appropriate steps to follow up initial solicitations.
 - (2) Selecting portions of the work to be performed by DBEs in order to increase the likelihood that the DBE goal will be achieved. This includes, where appropriate, breaking out contract work items into economically feasible units to facilitate DBE participation, even when the prime contractor might otherwise prefer to perform these work items with its own forces.
 - (3) Providing interested DBEs with adequate information about the plans, specifications, and requirements of the contract in a timely manner to assist them in responding to a solicitation.

WASHINGTON METROPOLITAN AREA TRANSIT AUTHORITY

SUPPLY AND SERVICE CONTRACT

IFB-FQ12235/CPR

- (4) (a) Negotiating in good faith with interested DBEs. It is the bidder's/proposer's responsibility to make a portion of the work available to DBE subcontractors and suppliers and to select those portions of the work or material needs consistent with the available DBE subcontractors and suppliers, so as to facilitate DBE participation. Evidence of such negotiation includes the names, addresses, and telephone numbers of DBEs that were considered; a description of the information provided regarding the plans and specifications for the work selected for subcontracting; and evidence as to why additional agreements could not be reached for DBEs to perform the work. "DBE Unavailability Certifications" (Attachment B-3) shall be completed as appropriate.
- (b) A bidder/proposer using good business judgment would consider a number of factors in negotiating with subcontractors, including DBE subcontractors, and would take a firm's price and capabilities as well as the contract goal into consideration. However, the fact that there may be some additional costs involved in finding and using DBEs is not in itself sufficient reason for a bidder's/proposer's failure to meet the contract DBE goal, as long as such costs are reasonable. Also, the ability or desire of a prime contractor to perform the work of a contract with its own organization does not relieve the bidder/proposer of the responsibility to make good faith efforts. Prime contractors are not, however, required to accept higher quotes from DBEs if the price difference is excessive or unreasonable.
- (5) Not rejecting DBEs as being unqualified without sound reasons based on a thorough investigation of their capabilities. The contractor's standing within its industry, membership in specific groups, organizations, or associations and political or social affiliations (for example union vs. non-union employee status) are not legitimate causes for the rejection or non-solicitation of bids/proposals in the contractor's efforts to meet the project goal.
- (6) Making efforts to assist interested DBEs in obtaining bonding, lines of credit, or insurance as required by the recipient or contractor.
- (7) Making efforts to assist interested DBEs in obtaining necessary equipment, supplies, materials, or related assistance or services.
- (8) Effectively using the services of available minority/women community organizations; minority/women contractors' groups; local, state, and Federal minority/women business assistance offices; and other organizations as allowed on a case-by-case basis to provide assistance in the recruitment and placement of DBEs.

7. BID AND PROPOSAL REQUIREMENTS (APPARENT SUCCESSFUL BIDDER/PROPOSER):

WASHINGTON METROPOLITAN AREA TRANSIT AUTHORITY

SUPPLY AND SERVICE CONTRACT

IFB-FQ12235/CPR

The bidder/proposer shall submit the following items within ten (10) calendar days after notification that they are the apparent successful bidder/proposer:

- A. A copy of a current WMATA, D.C. DOT or MWUCP certification letter(s) shall be attached to the DBE Schedule of Participation to evidence DBE pre-certification.
- B. DBE Manufacturer's Affidavit, if applicable, must be submitted in order to receive 100 percent of the allowable credit for expenditures to DBE manufacturers/suppliers (Attachment B-4). By submission of this Affidavit, the bidder/proposer certifies this it is satisfied that the manufacturer meets the requirements of 49 CFR Part 26.
- C. Schedule B Information for Determining Joint Venture Eligibility, if applicable (Attachment B-5, pgs. 1, 2, 3, 4). Submittal shall be signed by all parties, dated and notarized.
- D. Copy of Joint Venture Agreement, if applicable. Submittal shall be signed by all parties, dated and notarized.
- E. Certification letter of the DBE regular dealer/supplier, if applicable. If the bidder/proposer wants to receive the maximum allowable credit of its expenditures for material(s) or supplies required under this Contract, from DBE regular dealers/suppliers, the DBE must submit a signed and notarized statement on their letterhead, that they are a regular dealer of the material(s) or supplies. By submission of this statement, the bidder/proposer certifies that it is satisfied that the subcontractor is a regular dealer/supplier that meets the requirements of 49 CFR Part 26.
- F. For Design-Build contracts, if a DBE goal is specified in Section 00872, DBE GOAL REQUIREMENTS, the proposer shall submit with its initial Price Proposal a list of DBE-certified firms that it intends to enter into subcontract agreements with for this Contract. If no goal is specified in Section 00872 of the solicitation and the proposer still intends to utilize DBEs in the performance of this Contract, the proposer shall submit with its initial Price Proposal a list of those DBE-certified firms. The documentation requirements of Section 00453 of the solicitation shall be completed and submitted at the time set forth for the submittal of Best and Final Offer (BAFO) to the Authority for any Contract in which a DBE goal is applicable or for any Contract in which there was no goal established, but the proposer identified DBE-certified firms that it intends to enter into subcontract agreements with in its initial Price Proposal. Any proposer who fails to complete and return the following information, if applicable, with their BAFO Price Proposal may be deemed to be not responsible and may be ineligible for contract award. Proposers that fail to meet the DBE goal, if any, specified in Section 00872 and fail to demonstrate a good faith effort and to justify waiver of the DBE goal may be deemed to be not responsible and may be ineligible for contract award.

8. CONTRACT ADMINISTRATION REQUIREMENTS:

WASHINGTON METROPOLITAN AREA TRANSIT AUTHORITY

SUPPLY AND SERVICE CONTRACT

IFB-FQ12235/CPR

The following requirements apply after contract award:

- A. The Contractor shall include the following provision in the General Provisions of each subcontract it awards in support of the DBE goal:

“The contractor shall not discriminate on the basis of race, color, national origin or sex in the performance of this contract. The contractor shall carry out applicable requirements of 49 CFR Part 26 in the award and administration of US DOT assisted contracts. Failure by the contractor to carry out these requirements is a material breach of this contract, which may result in termination of this contract or such other remedy as the Buyer deems appropriate.”

- B. (1) The Contractor shall monitor the performance of, collect and report data on DBE participation to the WMATA’s DBE office on the attached “Prompt Payment Report-Prime Contractor’s Report” (Attachment B-6) which shall be submitted monthly with each payment request. Failure to submit these reports may result in suspension of contract payments. The Contractor shall certify with each payment request that payment has been or will be made to all subcontractors due payment, within ten (10) days after receipt of payment from the Authority for work by that subcontractor. The Contractor shall inform the COR or COTR, with their payment request, of any situation in which scheduled subcontractor payments have not been made and the reason therefore.
- (2) The Contractor shall require each sub-contractor to complete and forward to the DBE Liaison Officer on a monthly basis a “Prompt Payment Report-Subcontractor’s Report” (Attachment B-7). The sub-contractor shall certify that payment has been received.
- C. The Contractor shall have a continuing obligation to maintain a schedule for participation by DBE contractor(s) to meet its goal set forth above in this Appendix. The Contractor shall not have work performed nor the materials or supplies furnished by any individual or firm other than those named in the “Schedule of DBE Participation.” If at any time, the Contractor believes or has reason to believe that it needs to obtain a substitute for a DBE contractor named in the “Schedule of DBE Participation”, the Contractor shall, within ten (10) days, notify the contracting officer and the DBE office of that fact in writing. Situations which may warrant substitution for a DBE firm include, but are not limited to the following:
- (1) Evidence of change in ownership or circumstances regarding the firm’s status as a DBE.
- (2) Death or physical disability, if the named subcontractor or DBE partner of the joint venture is an individual.
- (3) Dissolution, if a corporation or partnership.

WASHINGTON METROPOLITAN AREA TRANSIT AUTHORITY

SUPPLY AND SERVICE CONTRACT

IFB-FQ12235/CPR

- (4) Bankruptcy of the subcontractor, subject to applicable bankruptcy law, and only instances where the bankruptcy affects the Contractor's ability to perform.
- (5) Inability to furnish a reasonable performance or payment bond, if required.
- (6) Inability to obtain, or loss of, a license necessary for the performance of the particular category of work.
- (7) Failure or inability to comply with a requirement of law applicable to contractors and subcontractors on a construction, alteration or repair project.
- (8) Failure or refusal to execute the subcontract in accordance with the terms of an offer submitted to the Contractor prior to the Contractor's submission of its bid/proposal, but only where the contracting officer or other delegated authority's representative can ascertain with reasonable certainty the terms of such offer. In the absence of any other factors, such a failure or refusal will be considered an unusual situation only if the bidder/proposer obtained, prior to bidding/proposing, an enforcement commitment from the subcontractor involved.
- (9) Failure to comply with the terms and conditions of this Contract or those of its subcontract or joint venture agreement.

Within 30 days thereafter, the Contractor shall, if necessary to achieve the Appendix B goal, make every reasonable effort to subcontract the same or other work equivalent in value to other certified DBE firms. The Contractor must have the prior written approval of the contracting officer and the DBE office before substitution for a DBE subcontractor, regardless of the reason for substitution. Failure to obtain Authority approval could result in the Authority declaring the Contractor ineligible to receive further Authority contracts for three years from the date of the finding.

- D. The contractor shall forward copies of all subcontracts to the DBE office at the time of their execution.
- E. If the contracting officer or other delegated authority's representative determines that the Contractor has failed to comply with this Appendix B, he/she will notify the Contractor of such non-compliance and the action to be taken. The Contractor shall, after receipt of such notice, take corrective action. If the Contractor fails or refuses to comply promptly, the contracting officer or other delegated authority's representative may issue a "stop work order" stopping all or part of the work until satisfactory corrective action has been taken. No part of the time lost due to any such stop work order shall be made the subject of claim for extension of time or for excess costs or damages by the Contractor. When the Authority proceeds with such formal actions, it has the burden of proving that the Contractor has not met the requirements of this Appendix, but the Contractor's failure to meet its Appendix B goal shall shift to it the requirement to come

WASHINGTON METROPOLITAN AREA TRANSIT AUTHORITY

SUPPLY AND SERVICE CONTRACT

IFB-FQ12235/CPR

forward with evidence to show that it has met the good faith requirements of this Appendix. Where the Contractor, after exhausting all its administrative and legal remedies and procedures is found to have failed to exert a "good faith effort" to involve DBE's in the work as herein provided, the Authority may declare the Contractor ineligible to receive further Authority contracts for three years from the date of the finding.

- F. The Contractor agrees to cooperate in any studies or surveys as may be conducted by the Authority which are necessary to determine the extent of the Contractor's compliance with this Appendix.
- G. The Contractor shall keep records and documents for two years following performance of this Contract to indicate compliance with this Appendix. These records and documents, or copies thereof, shall be made available at reasonable times and places for inspection by any authorized representative of the Authority and will be submitted upon request together with any other compliance information which such representative may require.
- H. If the Authority, the FTA or the US DOT has reason to believe that any person or firm has willfully and knowingly provided incorrect information or made false statements regarding the DBE Program, the matter shall be referred to the WMATA's DBE office.
- I. Failure by the Contractor to carry out the requirements of this Appendix is a material breach of this Contract, which may result in the termination of this Contract under the Default provision of this Contract or such other remedy as the Authority deems appropriate.

WASHINGTON METROPOLITAN AREA TRANSIT AUTHORITY

SUPPLY AND SERVICE CONTRACT

IFB-FQ12235/CPR

SUMMARY OF SUBMITTALS

With the Bid/Proposal

1. Completed "Schedule of DBE Participation" (Attachment B-1) with current certification letters attached for each listed DBE.
2. Executed "Letters of Intent to Perform as a Subcontractor/Joint Venture" (Attachment B-2).
3. Justification for grant of relief (waiver of DBE goal), if applicable. Include completed "DBE Unavailability Certifications" (Attachment B-3) as appropriate.

Bid and Proposal Requirements (Apparent Successful Bidder/Proposer)

1. All DBEs must submit a copy of their current WMATA or DC DOT certification letters or a certification letter issued by the MWUCP.
2. DBE Manufacturer's Affidavit, if applicable, must be submitted in order to receive 100 percent of the allowable credit for expenditures to DBE manufacturers/suppliers (Attachment B-4).
3. Schedule B Information for Determining Joint Venture Eligibility, if applicable (Attachment B-5, pgs. 1, 2, 3, 4).
4. Copy of Joint Venture Agreement, if applicable.
5. Certification letter of the DBE regular dealer/supplier, if applicable.

After Contract Award

1. "Prompt Payment Report-Prime Contractor's Report" Attachment B-6) – submitted monthly.
2. "Prompt Payment Report-Subcontractor's Report" (Attachment B-7) - submitted monthly.
3. Request to substitute DBE contractor (see paragraph 8.C.) – submitted as required.
4. Copies of subcontracts-submitted at the time of their execution.

WASHINGTON METROPOLITAN AREA TRANSIT AUTHORITY

SUPPLY AND SERVICE CONTRACT _____ IFB-FQ12235/CPR

SUBMIT WITH BID/PROPOSAL

SCHEDULE OF DBE PARTICIPATION

Contract No. _____

Project Name _____

Name of Bidder/Proposer

The bidder/proposer shall complete this Schedule by identifying only those DBE firms, with scope of work and price, who have agreed to perform work on this Contract. The prices for the work/supplies of these firms shall be at prices amounting to at least the DBE percentage goal of the total contract price. The bidder/proposer agrees to enter into a formal agreement with the DBE firm(s) listed for the work and at, or greater than, the prices listed in this Schedule subject to award of a Contract with the Authority. If the total amount is less than the DBE percentage goal, a justification for waiver of DBE goal shall be attached to this Schedule.

Name of DBE Subcontractor	Address	Type of Work (Electrical, Paving, Etc.) and Contract Items or Parts Thereof to be Performed and Work Hours Involved	Agreed Price
Subtotal \$ DBE Subcontractors			
Name of DBE Prime Contractor	Address	Type of Work (Electrical, Paving, Etc.) and Contract Items or Parts Thereof to be Performed and Work Hours Involved	Agreed Price
Subtotal \$ DBE Prime Contractor			
TOTAL \$ ALL DBE CONTRACTORS		TOTAL	

_____ Signature of Contractor Representative

_____ Title

_____ Date

WASHINGTON METROPOLITAN AREA TRANSIT AUTHORITY

SUPPLY AND SERVICE CONTRACT _____ IFB-FQ12235/CPR

Contract Number: _____

Project Name: _____

LETTER OF INTENT TO PERFORM AS A SUBCONTRACTOR/JOINT VENTURE
(ALL ITEMS MUST BE COMPLETED)

TO: _____
(Name of Bidder/Proposer)

The undersigned intends to perform work in connection with the above projects as (check one):

_____ an individual _____ a corporation
_____ a partnership _____ a joint venture

Specify in detail particular work items or parts thereof to be performed:

at the following price: \$

Please indicate _____ % of the dollar value of the subcontract that will be awarded to non-DBE contractors, if applicable. The undersigned will enter into a formal agreement with you for the above work upon your execution of a contract with the Authority.

Name of DBE Subcontractor/Joint Venture

Phone Number

Address

WMATA Vendor ID #/DBE Cert. #

Signature & Title

Date

The following is to be completed by the Prime Contractor. A copy of this letter must be returned to the DBE subcontractor to indicate acceptance.

To: _____
(Name of DBE)

You have projected your interest and intent for such work, and the undersigned is projecting completion of such work as follows:

WORK ITEMS	PROJECTED DBE COMMENCEMENT DATE	PROJECTED DBE COMPLETION DATE
_____	_____	_____

(Date)

(Name of Prime Contractor & Acceptance Signature)

WASHINGTON METROPOLITAN AREA TRANSIT AUTHORITY

SUPPLY AND SERVICE CONTRACT

IFB-FQ12235/CPR

SUBMIT WITH BID / PROPOSAL

DBE UNAVAILABILITY CERTIFICATION

I, _____, of _____,
(Name) (Title) (Bidder/Proposer)

certify that on _____ I contacted the following DBE contractor to obtain a proposal for work
(Date)
items to be performed on Contract Number _____.

DBE Contractor	Work Items Sought	Form of Bid Sought (i.e., Unit Price, Materials and Labor Only, Etc.)
_____	_____	_____

To the best of my knowledge and belief, said DBE contractors were unavailable (exclusive of unavailability due to lack of agreement on price) for work on this project, or unable to prepare a proposal, for the following reason(s):

Signature: _____

Date: _____

_____ was offered an opportunity to bid on the above
(Name of DBE Contractor)

identified work on _____ by _____
(Date) (Source)

The above statement is true and accurate account of why I did not submit a bid on this project.

(Signature of DBE Contractor)

(Title)



23.25 (Rev 10/99)

DBE Certification Instructions

Important Notice

If you do not have a current, official letter of certification from WMATA, D.C. DOT or MWUCP, you are not pre-certified and are therefore not eligible to participate as a Disadvantaged Business Enterprise on the proposal.

For those who wish to access the MWUCP certification application, it may be found on the internet at the following address:

https://www.wmata.com/business/disadvantaged_business_enterprise. Go to "Procurement and Contracting", click on "Disadvantaged Business Enterprise", then click on "DBE Application for Certification".

49 CFR Part 26 gives Metropolitan Washington Unified Certification Program (MWUCP) 90 days in which to process a complete DBE application. In order to become certified and participate in the MWUCP, you must comply with the procedures that follow. Certification must be final before the due date for bids or offers on a contract on which a firm seeks to participate as a DBE.

Instructions

49 CFR Part 26.81(d) of the Certification Procedures requires a firm to be certified as a DBE in it's "home state", where it has it's principal place of business, in order to become certified outside such "home state". Therefore, you must attach a copy of a valid DBE Certification letter from your home state Department of Transportation to the MWUCP Application. In addition, submit the pertinent documents for your company listed below. The application should be completed in full and NOTARIZED.

General (All firms must submit documents under General)

- Current (unaudited) Financial Statements
- Prior three (3) years Federal Tax Returns
- Resume of Principal(s) and Key Personnel
- Third Party Agreements, such as Rental and Management Agreements
- Licenses to Do Business
- Personal Net Worth (PNW) Statement
- Statement of Disadvantage
- No Change Affidavit or Notice of Change (where applicable)

Corporations

- Articles of Incorporation
- By-Laws
- Stock Ownership Options
- Copy of Stock Certifications of Each Holder
- Copy of Voting Rights
- Record of First Organizational Meeting

Partnerships

- Partnership Agreement

Proprietorships

IRS Employer ID Number
WMATA Vendor ID#

Limited Liability Companies

Operating Agreement
Certificate of Formation, Operating Agreement with any amendments
U.S. Corporate or Partnership Income Tax Returns

Change of Status Review

On or before each certification anniversary date, you must submit a No Change Statement attesting that there have been no changes in the firm's circumstances affecting its ability to meet the eligibility requirements of 49 CFR Part 26 or WMATA's DBE Program Plan. Those firms which have undergone changes in circumstances must submit a Notice Regarding Change for review by the Office of Procurement and Materials, DBE Unit. A review of these changes shall be made to determine if the firm is in compliance with the 49 CFR Part 26.

Affidavit Enclosure

NOTE: When completing MWUCP Application, complete all information blocks. Type "N/A" if item does not apply to you or your firm.

WASHINGTON METROPOLITAN AREA TRANSIT AUTHORITY

SUPPLY AND SERVICE CONTRACT IFB-FQ12235/CPR
DBE MANUFACTURER'S AFFIDAVIT

I hereby declare and affirm that I am _____ (Title)
and duly authorized representative of _____ (Name of Company),
a _____ owned and controlled enterprise
whose address is _____

I further declare and affirm that company employees (persons not on the payroll of and/or performing the
same tasks for disadvantaged owned business having any interest in the affiant's business) operate the following
company equipment relative to the manufacturing process:

Equipment

Type Function Model Age Make

Number of employees involved in the manufacturing process: _____

The undersigned swears that the foregoing statements are true and correct and fully understands that
WMATA may rely on these statements in determining whether a WMATA prime contractor purchasing goods from
the undersigned's manufacturing concern is entitled to a 100% credit of such purchases towards its DBE goal. The
undersigned further understands that any material misrepresentation will be grounds for initiating action under
Federal or state laws concerning false statements.

Signature of Affiant Printed Name

Date: _____ State: _____ County: _____

On this _____ day of _____, 19_____

before me appeared _____ (Name)

to me personally known, who, being duly sworn, did execute the foregoing Affidavit, and did state that he
or she was properly authorized by _____ (Name of Firm)

to execute the Affidavit and did so as his or her free act and deed.

(Seal) Sworn and subscribed before me _____ (Notary Public)

Commission Expires: _____

23.29 (10/99)

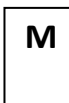

Information For Determining Joint Venture Eligibility

Page 1

.....

Name and address of Joint Venture:

Contact Person: _____ Telephone: _____

Have you attached a copy of the Joint Venture agreement? Yes No

NOTE: Affidavit will not be processed without a copy of the Joint Venture agreement.

.....

Name and address of Joint Venture partner: _____

Contact Person: _____ Telephone: _____

Status of firm: DBE. Non-Minority.

Does firm have current WMATA, DC DOT or MWUCP DBE certification? Yes No

.....

Name and address of Joint Venture partner: _____

Contact Person: _____ Telephone: _____

Status of firm: DBE. Non-Minority.

Does firm have current WMATA, DC DOT or MWUCP DBE certification? Yes No

.....

Describe the nature of the Joint Venture business:

Describe the role in the Joint Venture of each partner listed above:

Describe the experience and business qualifications of each partner in the Joint Venture listed above:

.....

Information For Determining Joint Venture Eligibility

Indicate the percentage of ownership in the Joint Venture for each Joint Venture partner, indicating dollar amounts wherever applicable.

Name of Partner	Percentage of Ownership	Profit and Loss Sharing	Capital Contributions including Equipment	Other Agreements
_____	_____	_____	_____	_____
_____	_____	_____	_____	_____
_____	_____	_____	_____	_____

TOTALS:

Identify by name, title, race, sex and company affiliation those individuals responsible for the management control of and participation in this contract:

1. Financial decisions, such as payroll, insurance, surety and/or bonding requirements:

Name: _____ Race: _____

Title: _____ Sex: Male Female

Company affiliation: _____

2. Management decisions, such as estimating, marketing and sales, hiring and firing, purchasing supplies:

Name: _____ Race: _____

Title: _____ Sex: Male Female

Company affiliation: _____

3. Supervision of field operations:

Name: _____ Race: _____

Title: _____ Sex: Male Female

Company affiliation: _____

Information For Determining Joint Venture Eligibility

.....
The undersigned swear that the foregoing statements are correct and include all material information necessary to identify and explain the terms and operations of our following named Joint Venture:

_____ and the intended participation by each Joint Venturer in the undertaking. Further the undersigned covenant and agree to provide the Authority current, complete and accurate information regarding actual Joint Venture work and the payment thereof and any proposed changes in any of the Joint Venture arrangements and to permit the audit and examination of the books, records and files of the Joint Venture, or those of each Joint Venturer relevant to the Joint Venture, by authorized representatives of the Authority or the Federal funding agency. Any material misrepresentation will be grounds for terminating any contract which may be awarded and for initiating action under Federal and State laws concerning false statements.

It is recognized and acknowledged that the Authority's DBE Program shall have access to the information provided herein above for the purpose of establishing eligibility and authenticity of the minority/woman-owned status of the Joint Venture.

It is understood that trade secrets and information privileged by law, as well as commercial, financial, geological and geophysical data furnished will be protected.

(NAME OF FIRM)

(NAME OF SECOND FIRM)

(SIGNATURE OF AFFIANT)

(SIGNATURE OF AFFIANT)

(PRINT NAME)

(PRINT NAME)

(TITLE)

(TITLE)

(DATE)

(DATE)



Information For Determining Joint Venture Eligibility

Page 4

.....
Date: _____ State: _____ County: _____

On this _____ day of _____, 19____,

before me appeared _____

(Name)

to me personally known, who, being duly sworn, did execute the foregoing Affidavit, and did state that he or she was properly authorized by _____

(Name of Firm)

to execute the Affidavit and did so as his or her free act and deed.

(Seal)

Sworn and subscribed before me _____

(Notary Public)

Commission Expires: _____
.....

Date: _____ State: _____ County: _____

On this _____ day of _____, 19____,

before me appeared _____

(Name)

to me personally known, who, being duly sworn, did execute the foregoing Affidavit, and did state that he or she was properly authorized by _____

(Name of Firm)

to execute the Affidavit and did so as his or her free act and deed.

(Seal)

Sworn and subscribed before me _____

(Notary Public)

Commission Expires: _____
.....



23.06c (Rev 10/99)

Washington Metropolitan Area Transit Authority

DISADVANTAGED BUSINESS ENTERPRISE (DBE)
MONTHLY PROMPT PAYMENT REPORT

PRIME – CONTRACTOR’S REPORT

This report is required to be submitted to the Office of Procurement, DBE Branch 600 5th Street, NW, Suite 3C, Washington, DC 20001, pursuant to the requirements of WMATA’s DBE Program Plan and §26.29 of 49 CFR Part 26.

Contract No.: _____ Reporting Period: _____

Name of Prime Contractor: _____ DBE – Yes or No _____

Prime Contract Amount: _____ Total Received this Reporting Period: _____ Total Received to Date: _____
DBE Goal _____

Name of Sub-Contractor	DBE (Y/N)	Description of Work	Date of Contract Awarded	Amount of Sub-Contractor Award	Amount Paid This Reporting Period	Cumulative Paid To Sub-Contractor	% of Physical Work Complete
TOTAL							

I certify the information furnished with respect to DBE subcontractor performance correct to the best of my knowledge and represents a current status of the prime contractor with the DBE subcontractors for the designated period covered by this report. Further, those subcontractors, due payment pursuant to the terms of their subcontracts will be paid within ten days after receipt of payment from WMATA.

By: _____ Title: _____ Date: _____

Washington Metropolitan Area Transit Authority

DISADVANTAGED BUSINESS ENTERPRISE (DBE)
MONTHLY PROMPT PAYMENT REPORT

SUBCONTRACTOR'S REPORT

This report is required to be submitted to the Office of Procurement, DBE Branch 600 5th Street, NW, Suite 3C, Washington, DC 20001, pursuant to the requirements of WMATA's DBE Program Plan and §26.29 of 49 CFR Part 26.

Contract No.: _____ Reporting Period: _____

Name of Subcontractor: _____ DBE – Yes or No

Subcontractor Contract Amount: _____ Total Received this Reporting Period: _____ Total Received to Date: _____

Name of Sub-Contractor	DBE (Y/N)	Description of Work	Date of Contract Awarded	Amount of Sub-Contractor Award	Amount Paid This Reporting Period	Cumulative Paid To Sub-Contractor	% of Physical Work Complete
TOTAL							

I certify the information furnished with respect to DBE subcontractor performance correct to the best of my knowledge and represents a current status for the designated period covered by this report. Further, those contractors, due payment pursuant to the terms of their subcontracts will be paid within ten days after receipt of payment from the Contractor.

By: _____ Title: _____ Date: _____



Washington Metropolitan Area Transit Authority
600 5th Street, NW
Washington, DC 20001

TECHNICAL SPECIFICATION

Direct Fixation Rail Fasteners

REV.	DATE	REVISION DETAILS	RELEASE NO.	INIT.
0	4/06/2011	First Issue	RLN-000	AB
1	7/12/2012	Revised Format to exclude Procurement Activity	RLN-000	AB

ORIGINATED BY:  _____
Anderson Bray -Manager TRST, WMATA

DATE: 7/12/2012

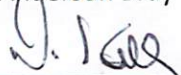
APPROVED BY:  _____
Darwin L. Kelly - General Superintendent TSSM, WMATA

DATE: 7/25/2012

Table of Contents

- 1.0 SCOPE 3**
- 2.0 APPLICABLE DOCUMENTS 3**
- 3.0 TECHNICAL SPECIFICATIONS 4**
 - 3.1 GENERAL REQUIREMENTS 4
 - 3.2 CONFIGURATION 6
 - 3.3 FASTENER BODY 7
 - 3.4 INSPECTION AND ACCEPTANCE TESTING 9
 - 3.5 ELASTOMER TESTING 11
 - 3.6 FASTENERS BODY METAL TESTING 14
 - 3.7 FASTENER ASSEMBLY TESTING 14
 - 3.8 PRODUCTION QUALITY CONTROL 22
 - 3.9 DELIVERY CONDITIONS 25
 - 3.10 REFERENCE DRAWINGS 26

1.0 Scope

1.1.1 The work under this section consists of the designing, manufacturing, inspecting, testing, shipping, and delivering “stiff” direct fixation rail fasteners, hereafter referred to as “Rail Fasteners”, for securing running rail to epoxy grout pad and concrete track bed in direct fixation track. The Rail Fasteners shall meet, as a minimum, all the requirements as defined in this Technical Specification.

2.0 Applicable Documents

- a) ASTM A536 “Standard Specifications for Ductile Iron Castings”
- b) SAE J434 “Automotive Ductile Iron Castings”
- c) ASTM E10 “Standard Test Method for Brinell Hardness of Metallic Materials”
- d) ASTM B633 “Standard Specification for Electrodeposited Coatings of Zinc on Iron and Steel”
- e) ASTM A325, “Standard Specifications for Structural Bolts, Steel, Heat Treated, 120/105 ksi Minimum Tensile Strength”
- f) ASTM C39, “Compressive Strength of Cylindrical Concrete Specimens”
- g) ASTM A615, “Standard Specifications for Deformed and Plain Billet-Steel Bars for Concrete Reinforcement”.
- h) ASTM D2240, “Indentation Hardness of Rubber and Plastics by Means of a Durometer”
- i) ASTM D412, "Tension Testing of Vulcanized Rubber"
- j) ASTM D395, "Compressed Set of Vulcanized Rubber"
- k) ASTM D573, "Accelerated Aging of Vulcanized Rubber by the Oven Method"
- l) ASTM D518, "Resistance to Surface Cracking of Stretched Rubber Components"
- m) ASTM D1149, "Accelerated Ozone Cracking of Vulcanized Rubber"
- n) ASTM D1229, "Low Temperature Compression Set of Vulcanized Elastomers"
- o) ASTM D471, "Change in Properties of Elastomeric Vulcanizates Resulting from Immersion in Liquids"
- p) ASTM D429, "Adhesion of Vulcanized Rubber to Metal, Method A"

- q) ASTM D624, "Standard Test Method For Rubber Property - Tear Resistance"
- r) ASTM E162, "Standard Test Method For Surface Flammability of Materials Using a Radiant Heat Energy Source"
- s) ASTM D257 "Standard Test Method for D-C Resistance or Conductance of Insulating Materials"
- t) ASTM D570, "Standard Test Method for Water Absorption of Plastics"
- u) ASTM E23, "Standard Method for Notched Bar Impact Testing of Metallic Materials"
- v) ASTM B117, "Standard Test Method for Salt Spray (Fog) Testing"
- w) ASTM D2084, "Standard Test Method for Rubber Property-Vulcanization Using Oscillating Disk Cure Meter"

3.0 Technical Specifications

3.1 GENERAL REQUIREMENTS

- 3.1.1 The Rail Fastener shall be for use with 115RE running rail.
- 3.1.2 The Rail Fastener assembly shall be comprised of as few components as is economically and technically feasible for ease of assembly, disassembly and maintenance.
- 3.1.3 The Rail Fastener assembly shall be designed to permit quick installation or replacement of the entire assembly, or any of its components, by one man using hand tools.
- 3.1.4 The Rail Fastener assembly shall be comprised of the rail fastener body, two (2) rail hold down spring clips, two (2) fastener body anchorage adjustment washers, and two (2) anchor bolts. (The fastener body anchor bolts to be furnished by others).
- 3.1.5 The rail fastener body shall be comprised of a ductile iron top plate, a ductile iron bottom plate, and an elastomeric material between them which is vulcanized bonded to both plates during the molding process.

- 3.1.6 The rail hold down assembly shall be comprised of two (2) Pandrol 2056 e clips, one on each side of the rail, for securing the running rail to the top plate of the rail fastener body.
- 3.1.7 The fastener body anchorage assembly shall be comprised of two (2) female type anchorage inserts for embedment into the epoxy grout on a concrete track bed and two anchor bolts for securing the fastener body to the anchor inserts and to the concrete track bed. The fastener body anchorage design shall not pass through the top plate and shall anchor thru the bottom plate only. (The fastener body anchorage assembly to be furnished by others).
- 3.1.8 The rail hold down assemblies shall be designed so that when removed, the rail may be lifted vertically until it is completely free of the Rail Fastener without disturbing the horizontal or vertical alignment of the rail fastener body.
- 3.1.9 The rail fastener body design shall provide on each side of the rail base a positive means of preventing more than 1/8" total lateral movement of the rail base relative to the fastener in event of failure or loosening of one or both rail holddown assemblies. The design feature shall be integral cast into the top plate component at a minimum height of 9/32" from the top of the rail seat and shall extend across the entire width of the fastener body in the direction longitudinal to the running rail on both field and gage sides.
- 3.1.10 The rail hold down assembly device shall not be dependent on elastomeric components in torsion.
- 3.1.11 Each Rail Fastener shall be furnished with all components required for all specified increments of lateral adjustment
- 3.1.12 Bonding of any part of the Rail Fastener to the grout pad will not be permitted.
- 3.1.13 Longitudinal and lateral restraint properties of the Rail Fastener shall be identical in both directions.
- 3.1.14 The stability of the Rail Fastener in the lateral direction shall not be dependent solely upon the strength of the bond of the elastomer to metal.
- 3.1.15 All surfaces of the metal parts adjacent to the elastomer shall be coated with the primer and cement used to form the bond during the molding process.

3.1.16 All Rail Fasteners shall be marked in a permanent manner to indicate a lot number and a specific number to identify each fastener. The method and sequence of numbering shall be submitted to WMATA for approval.

3.1.17 Welding in the fabrication or assembly of any Rail Fastener component will not be permitted.

3.2 CONFIGURATION

3.2.1 The assembled Rail Fastener shall be within the Rail Fastener envelope shown in Section 3.10.1.

3.2.2 The assembled Rail Fastener shall have no cant to the rails. The slope tolerance shall not exceed plus or minus 0.35%. The rail seat area shall be flat with maximum convexity and concavity of less than 0.001" per inch.

3.2.3 The overall distance between the base of the Rail Fastener and the base of the rail with the Rail Fastener in the installed position shall be 1-1/2 ".

3.2.4 When completely assembled, the overall dimensions of the Rail Fastener, including the elastomer, shall stay within a design envelope of 7" to 9" in width measured parallel to the rail and 14" to 16" in length measured normal to the rail.

3.2.5 The fastener body anchorage assembly shall provide for two (2) anchor bolts, each 7/8" in diameter, for securing the fastener to the epoxy grout pad and concrete track bed. The anchor bolts shall be symmetrically located as shown in Appendix Drawings with respect to the rail fastener body center lines. As shown in Appendix Drawings the anchorage assembly bolts shall be located in the upper right-hand quadrant and low left-hand quadrant of the Rail Fastener as referenced along the centerline of rail. (The fastener body anchorage assembly shall be furnished by others).

3.2.6 The Rail Fastener shall also be designed to be capable of being anchored by placement over existing 7/8" threaded stud bolts in lieu of the anchor bolts and female anchor inserts.

3.2.7 The adjustment washers shall be designed so that they can be used for either the anchor bolts or the threaded studs.

- 3.2.8 The rail fastener body shall provide a means of 1" total lateral adjustment having a range of plus or minus 1/2" via a serrated mechanism at each anchor location. Serration shall be vertical, a minimum of 5/32" high, and integrally cast into the bottom plate. The bottom of the vertical serration shall be raised a minimum of 1/8" above the top of the bottom plate. Together with a serrated adjustment washer, the system shall allow adjustment in either lateral direction in increments of 1/8". Friction alone as a means of adjustment will not be permitted. The serration shall have not less than three interlocking serrations engaged in any position of lateral adjustment. The adjustment feature shall be integral with the rail anchorage assemblies.
- 3.2.9 The rail fastener body shall provide an electrical leakage distance of not less than 1- 1/8" measured from the grounded portion of the fastener to the charged portion by the most direct path that does not pass through an insulating material. The minimum distance of separation between any point of the top plate to the bottom plate shall be 1/2" and shall contain a full and complete section of elastomer material. The entire top and side surfaces of the metal plates of the fastener body shall contain a minimum coating of 1/16", exclusive of the serrated area of the fastener body anchorage location.
- 3.2.10 The underside of the rail fastener body shall be a flat, continuous plane with no projections below the top of the grout pad.
- 3.2.11 The rail fastener body shall have at least 1/2 " thick elastomeric material fully from the underside of top plate and top side of the bottom plate.
- 3.2.12 The Rail Fastener design shall be such that the elastomer is not pre-compressed by the rail fastener anchorage assembly.
- 3.2.13 No portion of the completely assembled Rail Fastener, including rail clips and anchor bolts, shall extend any higher than 3-1/2" measured vertically from the base of the rail centerline.
- 3.2.14 Recesses in the Rail Fastener shall be free draining in all positions of lateral adjustment up to a maximum actual super elevation of 4-1/2".

3.3 FASTENER BODY

3.3.1 Metal Components

3.3.1.1 Both the metal top plates and bottom plates shall be one-piece ductile iron. The minimum thickness of the top plate shall be 1/2" and 3/8" for the bottom plate.

3.3.1.2 The ductile iron castings shall be Grade 65-45-12 in accordance with ASTM A536, "Standard Specifications for Ductile Iron Castings". The chemical composition shall meet the acceptable level per SAE J434, "Automotive Ductile Iron Castings". The Brinell hardness when tested in accordance with ASTM E10, "Standard Test Method for Brinell Hardness of Metallic Materials", shall be within 156-217 BH range per SAE J434.

3.3.2 Elastomer

3.3.2.1 The minimum thickness of the elastomer between the top plate and the bottom plate parallel to the rail seat shall be 1/2".

3.3.2.2 The elastomer shall be neoprene or natural rubber or a blend of neoprene and natural rubber.

3.3.3 Manufacturing Tolerances

- a) Length and width - plus or minus 1/8".
- b) Height - plus or minus 1/32".
- c) Squareness - angles within plus or minus 1/32".
- d) Centering of holes - plus or minus 1/32".
- e) Diameter of holes - plus or minus 1/32".
- f) Durometer Shore A - plus or minus 5.
- g) Serration depth - plus or minus 1/64".
- h) Serration spacing - plus or minus 1/64".
- i) Width between shoulders at rail base - plus 1/16" or minus 0".

3.3.4 Rail Hold Down Assembly

3.3.4.1 Rail clip shall be the Pandrol e-2056 (left handed). Rail clip shoulder shall be cast as integral part of the metal top plate. Welding of the rail clip shoulder to the top plate will not be permitted.

3.3.4.2 Anchor bolts shall be 7/8" in diameter, carbon steel, electroplated with zinc in accordance with ASTM B633, Type II, SC 4.

3.4 INSPECTION AND ACCEPTANCE TESTING

3.4.1 General

3.4.2 The qualification tests specified herein shall be performed by an independent testing facility approved by WMATA and shall be a member of the American Council of Independent Laboratories. All testing shall be performed at no additional cost to the Authority and is to be performed post-award and prior to manufacture of production quantities.

3.4.3 Before beginning any tests, a detailed description of all tests shall be submitted to WMATA for approval. The description shall completely detail the test procedure and shall include drawings showing the relationship of the fastener and all significant components of the testing equipment, including the test block and anchor bolts.

3.4.4 From a lot of not less than twenty standard direct fixation fasteners, sixteen will be selected at random by WMATA. If additional fasteners are necessary to meet these test requirements they shall be furnished at no additional cost to the Authority.

3.4.5 Each of the fasteners selected for testing shall be carefully measured and examined to determine the compliance with these specifications and the approved shop drawings. Upon satisfactory completion of this examination eight (8) fasteners will be retained by the Authority and the remaining eight fasteners shall be returned to the Contractor for execution of the qualification performance tests by an independent laboratory.

3.4.6 Except as otherwise specified herein, each test shall be performed on two (2) completely assembled Rail Fasteners at 30" center-to-center spacing, with a section of 115RE rail not less than 42" long mounted and clipped thereon. Before assembly, all parts shall be cleaned and dried. The fastener shall be assembled as shown in the approved shop drawings and installation description, and all threaded elements shall be tensioned as specified.

3.4.7 The test fasteners shall be mounted on a concrete test block and anchored with 7/8" diameter ASTM A325, "Standard Specifications for Structural Bolts, Steel, Heat Treated, 120/105 ksi Minimum Tensile Strength", threaded stud bolts to

simulate field installation. The anchorage shall not fail under loadings imposed by any test specified below.

- 3.4.8 The concrete test block shall be reinforced concrete with dimensions as shown in Section 3.10.2. The concrete shall have minimum 28 day strength of 4,000 lbs. per square inch as determined by ASTM C39, "Compressive Strength of Cylindrical Concrete Specimens". The reinforcing steel shall be Grade 60 per ASTM A615, "Standard Specifications for Deformed and Plain Billet-Steel Bars for Concrete Reinforcement".
- 3.4.9 Two (2) pairs of threaded stud bolts shall be drilled and epoxied into the concrete test block. The stud bolts shall project 3-1/2" out from the top surface of the concrete. The stud bolts shall be positioned as they would be in track for two (2) fasteners 30" apart measured parallel to the rail. The holes for the dowels shall be 1-1/8" to 1-3/4" diameter and 5-1/2" deep. The epoxy to be used shall provide minimum unrestrained pullout strength of 20,000 lbs. As an alternate, the stud bolts may be replaced with 7/8" anchor bolts and female inserts epoxy grouted into the concrete block.
- 3.4.10 Before commencing any tests the Rail Fastener(s) shall be stabilized at a temperature of 24° C, plus or minus 6° C for a minimum of four hours.
- 3.4.11 Should any fastener assembly fail a test, the entire sequence of test on the eight (8) new fastener assemblies shall be performed again. Should a fastener assembly from a sample lot fail a test, the entire lot will be rejected and the Contractor is to provide a new random sample lot to WMATA, from which a sample of eight (8) fasteners will be returned to the Contractor for testing by the independent laboratory. If the design of the fastener must be modified to pass any test, shop drawings of the new design shall be submitted to and approved by WMATA before retesting is continued.
- 3.4.12 At least ten (10) fastener assemblies of the new design shall be manufactured and all tests on the new fastener design shall be performed. The revision, approval and test cycle shall be continued until the fastener assemblies are accepted. Four (4) weeks is allotted for redesign, approval, and testing commencement. The Authority reserves the right to terminate the Contract for default should the Contractor fail to develop an approvable fastener within a reasonable amount of time after award so as to prevent their capability of complying with the delivery schedule. Should the failure to develop an

approvable fastener be due to circumstances beyond the control of the Contractor, an extension may be considered.

3.5 ELASTOMER TESTING

3.5.1 The following tests shall be performed on each of two (2) specimens that are identical in all respects to the elastomer proposed for use in the direct fixation rail fasteners. These samples shall be certified to have been taken from a batch of compound used for producing the elastomeric component of the fastener and having a cure equivalent to the cure of the elastomer component. Prior to testing, all elastomer specimens shall be conditioned for not less than two (2) days at 23° C plus or minus 2° C and 50 % plus or minus 5 % relative humidity.

3.5.1.1 Hardness Test

- a) The elastomer shall be tested in accordance with ASTM D2240, "Indentation Hardness of Rubber and Plastics by Means of a Durometer", to determine the hardness of elastomer.
- b) The hardness shall be between 45 and 55 durometer, Shore A.

3.5.1.2 Tensile Strength and Ultimate Elongation Test

- a) The elastomer shall be tested in accordance with ASTM Designation D412, "Tension Testing of Vulcanized Rubber", to determine the tensile strength and the ultimate elongation.
- b) The tensile strength shall be not less than 2350 psi and the ultimate elongation shall be not less than 400 %.

3.5.1.3 Compression Set at 100° C Test

- a) The elastomer shall be tested for 22 hours at 70° C in accordance with ASTM Designation D395, "Compressed Set of Vulcanized Rubber", Method B, to determine the percent of compression set.
- b) The compression set shall not exceed 25 %.

3.5.1.4 Accelerated Aging of Rubber

- a) The elastomer shall be aged for 70 hours at 70° C in accordance with ASTM Designation D573, "Accelerated Aging of Vulcanized Rubber by the Oven Method". The change of hardness and the percentage of change of

properties from the original tensile strength and original ultimate elongation shall be measured and recorded.

- b) The percentage of decrease in tensile strength shall not exceed 25 %. The percentage of decrease for ultimate elongation shall not exceed 25 %. An increase in hardness, measured on the Durometer A scale, shall not exceed 10 points.

3.5.1.5 Resistance to Ozone Cracking Test

- a) Test specimens shall be prepared in accordance with Procedure A of ASTM Designation D518, "Resistance to Surface Cracking of Stretched Rubber Components". The test specimens shall be tested in accordance with ASTM Designation D1149, "Accelerated Ozone Cracking of Vulcanized Rubber" at a temperature of 40 C, and at an ozone concentration of 50 pphm.
- b) The elastomer shall not exhibit any cracking when examined in accordance with ASTM Designation D1149 at the end of a 100 hour exposure.

3.5.1.6 Compression Set at Low Temperature

- a) The elastomer shall be tested at -10° C for 70 hours in accordance with ASTM Designation D1229, "Low Temperature Compression Set of Vulcanized Elastomers", to determine the percent of compression set at 30 minutes after release (t30 reading). The compression set shall not exceed 37 %.

3.5.1.7 Oil Absorption Test

- a) One test shall be conducted with IRM 903 (No. 3) oil at 23° C for 70 hours and another test using a different sample shall be conducted with IRM 901 (No.1) oil at 23° C for 70 hours in accordance with ASTM Designation D471, "Change in Properties of Elastomeric Vulcanizates Resulting from Immersion in Liquids" to determine the volume change of the elastomer.
- b) The volume change for the No. 1 oil shall not exceed 10 %. The volume change for the No. 3 oil shall not exceed 60 %.

3.5.1.8 Adhesion to Metal Test

- a) This test shall be performed on specimens of elastomer which are to be bonded in the finished fastener in accordance with ASTM Designation D429, "Adhesion of Vulcanized Rubber to Metal, Method A".

- b) The failure must be a type R failure (i.e., elastomer tears before bond fails). The metal substrate, preparation, adhesive and bonding process shall be the same as that used for the manufacture of the Rail Fastener.

3.5.1.9 Resistance to Tearing Test

- a) When tested in accordance with ASTM D624, "Standard Test Method For Rubber Property - Tear Resistance".
- b) The resistance to tearing shall not be less than 100 lbs. per inch.

3.5.1.10 Flame Spread and Smoke Generation Test

- a) The elastomer shall be tested in accordance with ASTM E162, "Standard Test Method For Surface Flammability of Materials Using a Radiant Heat Energy Source", to determine the Flame Spread Index. The elastomer shall be tested in accordance with NFTA No. 258-1982. Smoke Generated by Solid Material Test, in both the flaming and nonflaming modes to determine the Smoke Generation Specific Optical Index.
- b) The elastomer shall not exhibit any flaming dripping when tested. No acceptance criteria are specified for the Flame Spread Index and the Smoke Generation Specific Optical Index. These indices shall be reported to the Authority for information only.

3.5.1.11 Electrical Resistivity Test

- a) The elastomer shall be tested in accordance with ASTM D257 "Standard Test Method for D-C Resistance or Conductance of Insulating Materials", to determine the resistivity of the elastomer. For testing under wet conditions, immerse elastomer in potable water with a resistivity of 1,000 to 1,500 ohm-cm. Adjust resistivity of potable water if required by addition of sodium chloride.
- b) The minimum volume resistivity under dry condition shall be 10^{12} -ohm-cm and 10^{11} -ohm-cm under wet condition.

3.5.1.12 Water Absorption Test

- a) The elastomer shall be tested in accordance with ASTM D570, "Standard Test Method for Water Absorption of Plastics", to determine the change in weight of elastomer due to absorption of water. Immerse specimens in distilled water for 24 hours at a temperature of 23° C prior to testing.
- b) The elastomer shall have a maximum increase in weight of 1.0 %.

3.6 FASTENERS BODY METAL TESTING

3.6.1 Three (3) Charpy impact test specimens shall be prepared in accordance with ASTM E23, "Standard Method for Notched Bar Impact Testing of Metallic Materials", from the same metal used for the top and bottom plates of the fastener body. A Charpy impact test shall be conducted on each specimen at a temperature of 21 C.

3.6.2 The fracture energy shall be greater than three foot-pounds.

3.7 FASTENER ASSEMBLY TESTING

3.7.1 Eight (8) complete rail fastener assemblies are required to conduct the tests. Two (2) fasteners shall be assembled and mounted on each concrete test blocks designated as A, B, C and D. The fasteners shall be subjected to the following sequences of tests and as shown in Section 3.10.3.

3.7.2 All fasteners shall be subjected to each of the static tests as specified below:

3.7.2.1 Fastener A shall undergo the Vertical and Lateral Repeated Load Test and then undergo the Repeated Load Test with One Anchor Bolt. Fastener A shall then again undergo each Static Test without replacement of any component. For the Longitudinal Restraint Test, the fasteners shall not be disassembled from the rail after the Repeated Load Test with One Anchor Bolt, nor shall the rail hold down assemblies be retorqued.

3.7.2.2 Fastener B shall be subjected to Dynamic to Static Stiffness Ratio Test, then undergo Heat Aging Process, and then retested through each of the Static Tests without replacement of any component followed by another Dynamic to Static Stiffness Ratio Test.

3.7.2.3 Fastener C shall be subjected to Heat Aging Process, the Uplift Repeated Load Test, the Corrosion Process, and then retested through each of the Static Tests without replacement of any component followed by another Dynamic to Static Stiffness Ratio Test.

3.7.2.4 Fastener D shall be tested as specified below for the Push-Pull Test. Fastener D shall then be retested through each of the tests for Static Tests, without replacement of any component. For the Longitudinal Restraint Test, the fasteners shall not be disassembled from the rail after the Push-Pull Test, nor shall the rail hold down assemblies be retorqued.

3.7.3 Static Tests

3.7.3.1 Vertical Load Test

a) A vertical load increasing in increments of 2,000 lbs. to a maximum load of 32,000 lbs. shall be applied downward at the center of the rail head midway between the two fasteners and normal to the rail.

b) Acceptance Criteria:

3.7.3.2 The fastener stiffness shall be calculated as the slope of a straight line determined by a linear least-squares regression of the load per fastener versus each deflection for load per fastener between 4,000 lbs. and 12,000 lbs.. The fastener stiffness shall be within 15 % of 140,000 lbs. per inch. The load versus displacement curve shall be within the limits identified in Section 3.10.4.

a) The tangent to load-versus-deflection curve at each load between and including 4,000 lbs. and 12,000 lbs. per fastener shall be within 20 % of the fastener stiffness determined above. For the purpose of calculation, the tangent to the load versus deflection curve at each deflection, X_n , and each load, P_n , are approximated as:

$$(P_{n+1} - P_{n-1}) / (X_{n+1} - X_{n-1})$$

where P is the load at deflection X_n .

b) Total deflection of the elastomer at the 15,000 pound load per fastener shall not exceed 25 % of the uncompressed thickness. After removal of the maximum load, the fastener shall return to within 0.005" of its original position within one minute. At no time during the tests shall a fastener component exhibit any sign of failure by slippage, yielding, fracture, or bond failure.

c) Values obtained when this test is repeated, after performance of other tests, shall be within 10 % of the initial test values.

3.7.4 Vertical Uplift Test

3.7.4.1 A vertical load shall be applied to the center of the rail head midway between the two fasteners and normal to the rail, alternating from a vertical downward load to a vertical upward load. The peak load per cycle shall be increased in increments of 200 lbs. each cycle to 4,800 lbs.. The loads and deflections shall be continually measured to the nearest 0.001" and simultaneously recorded on a load versus time graph and a deflection versus time graph respectively. The load shall be removed and the final position of the rail head measured and recorded. The reaction force to the uplift load shall be applied to the test block on which the fastener is mounted.

3.7.4.2 Acceptance Criteria:

3.7.4.3 The ratio of the deflection for the total uplift test load to the deflection for the total vertical downward test load shall be between plus 5 % and plus 135 % of the deflection for a 4,000 pound downward vertical load as determined from the Vertical Load Test. When the vertical load is continuously varied from vertical downward loads to uplift loads, there shall be no indication of backlash or free play at times when the load or the deflection changes direction.

3.7.4.4 After removal of the maximum load, the rail shall immediately return to within 0.005" of its original position.

3.7.4.5 At no time during the test shall any fastener component, including the anchorage to the test block, exhibit any sign of failure by slippage, yielding or fracture.

3.7.5 Lateral Load Test

3.7.5.1 While applying a vertical load of 27,000 lbs. downward at the center of the rail head midway between the two fasteners and normal to the rail, a lateral load, increasing in increments of 1,000 lbs. to a maximum load of 16,000 lbs., at a rate of 1,000 lbs. per minute, shall be applied horizontally to the rail head at a point 0.625" below the top of rail at the location of vertical load.

3.7.5.2 For each load increment, the lateral deflection of the rail head at a point 0.625" below the top of rail shall be measured to the nearest 0.001" and recorded. The lateral load shall be removed and the final position of the rail head measured and recorded. The recorded values for lateral load versus deflection shall be plotted on a graph similar to Section 3.10.5.

3.7.5.3 Acceptance Criteria

3.7.5.4 The lateral load versus deflection curve for each fastener shall lie within the envelope shown on Section 3.10.5. The lateral deflection of the rail head for a lateral load of 4,000 lbs. per fastener shall not exceed 0.150". The average lateral deflection at maximum load shall not exceed 0.360". After removal of the load, the difference between the original and final positions of the gauge line shall not exceed 0.062". At no time during the test shall any fastener component exhibit any sign of failure by slippage, yielding or fracture.

3.7.6 Lateral Restraint Test

3.7.6.1 A lateral load increasing in increments of 1,000 lbs. from 0 lbs. to 10,000 lbs. shall be applied normal to the rail at the base of rail midway between the two fasteners. The lateral deflection of the rail shall be measured at the intersection of the centerline of the fastener and the gauge line of the rail to the nearest 0.001" and recorded after each increment of loading.

3.7.6.2 Acceptance Criteria

3.7.6.3 At no time during the test shall any component of the fastener show signs of slippage, yielding, or fracture. The difference between the original and final positions of the gauge line shall not exceed 0.062". The lateral deflection of the rail when fully loaded shall not exceed 0.125" from original gauge line of the rail.

3.7.7 Longitudinal Restraint Test

3.7.7.1 During the longitudinal restraint test, the rail ends shall be supported on a roller or other low friction supports, properly elevated to prevent the longitudinal load from binding the rail in the fastener.

3.7.7.2 A load shall be applied longitudinally at the centerline of rail at the base of the rail increasing in increments of 500 lbs. up to a total of 7,000 lbs. or until the rail deflects 0.6" from the initial condition, whichever occur first. The rate at which load is applied shall be approximately 1,000 lbs. per minute. Each load increment shall be maintained constant at a minimum of 30 seconds or until the longitudinal deflection of the rail ceases before increasing the load to the next increment.

3.7.7.3 For each load the longitudinal deflection of the rail relative to the fastener shall be measured to the nearest 0.001" and recorded. The longitudinal load shall be removed at slippage of rail and the final position of the rail measured and recorded. The recorded values for longitudinal load versus deflection shall be plotted on a graph as shown on Section 3.10.6.

3.7.7.4 Acceptance Criteria

3.7.7.5 The longitudinal load versus deflection curve, when plotted on Section 3.10.6, shall lie entirely within the shaded area. The difference between the original and final positions of the rail shall not exceed 0.125" plus the slippage distance of the rail. At no time during the test shall any fastener component exhibit any sign of failure by slippage, yielding, bond failures or fracture except that slippage which may occur between the rail clip and the rail.

3.7.8 Voltage Withstand Test

3.7.8.1 Prepare a fully assembled fastener and apply a DC potential of 15KV between the rail head and the metal base plate of the fastener body for one minute.

3.7.8.2 Acceptance Criteria

3.7.8.3 The elastomer shall withstand this test with no visible damage such as splits, cracks, pinholes or fractures, and no evidence of arcing, arc tracking, or other voltage breakdown.

3.7.9 Electrical Resistance and Impedance Test

3.7.9.1 A completely assembled fastener shall be mounted on 1/4" thick metallic ground plate sized to extend 1/2" beyond all edges of the fastener.

3.7.9.2 Dry Resistance

- a) 24 hours prior to testing, the assembled fastener shall be stored in a clean, dry environment with ambient temperature of 60 F to 80 F and 50 to 70 % humidity.
- b) 100 volts DC shall be applied between the rail head and the ground plate for three minutes. The applied voltage and the resulting current flow shall be measured, or the resistance shall be directly measured with an accuracy of plus or minus 2 %.

3.7.9.3 Wet Resistance

- a) This test shall be performed on the same fastener that passed the Dry Resistance Test. The assembled fastener shall be placed in a nonmetallic trough or suitable container. The container shall be sized such that there is a minimum of 2" between the sides and bottom of the fastener/ground plate assembly and sides and bottom of the container. Water shall be poured into the container to a level midway up to the rail web covering all surfaces of the fastener. This level of immersion shall be maintained for ten (10) minutes
- b) The water resistivity shall be 1,000 to 1,500 ohm-cm (use potable water and adjust resistivity by addition of sodium chloride). Water shall be drained from container to a level 1/2" below the ground plate, and without drying or otherwise disturbing the fastener, 100 volts DC shall be applied to the rail head and ground plate and the resistance shall be calculated within 15 seconds. Measurement and calculation shall be repeated every five (5) minutes for the first hour and every ten minutes for the second hour.

3.7.9.4 Electrical Impedance

- a) On a fully assembled fastener, a potential of 50 volts AC shall be applied to the rail head for three (3) minutes for each increment of measurement for frequencies from 20Hz to 10kHz, in increments of 20Hz up to 100 Hz, 200 Hz to 1,000 Hz, and 2,000 Hz up to 10kHz. The impedance shall be measured after three minutes with an accuracy of plus or minus 2 % and shall be recorded for each frequency.

3.7.9.5 Acceptance Criteria

- a) Dry DC Resistance - Not less than 20 megohms.
- b) Wet DC Resistance - Not less than one megohms for the average of three consecutive readings within two (2) hours after draining. The difference between each of the three readings and the average reading shall not exceed 10 % of the average reading.
- c) The minimum impedance for any frequency between 100 Hz through 10 kHz shall not be less than 9,800 ohms.

3.7.10 Vertical and Lateral Repeated Load Test

- 3.7.10.1 Loads shall be applied to the rail head in such a manner as to produce a vertical downward load of 28,000 lbs., and lateral loads midway between the two fasteners, 0.625" below top of rail, of 8,000 lbs. to the gauge side of the

rail head and 5,000 lbs. to the field side of the rail head. The application of the lateral loads shall be alternated, each combined with alternate application and release of the vertical load, a total of three million complete cycles. Application of the field side load and then the gauge side load with two applications of the vertical load constitutes one cycle. The frequency shall be regulated to prevent the temperature of the components from exceeding 70 C. Retorquing of threaded elements subsequent to the completion of 500,000 cycles of loading will not be permitted without the written approval of WMATA.

3.7.10.2 Acceptance Criteria

3.7.10.3 The fastener shall withstand the three million cycles of load application with no evidence of failure by slippage, yielding, wear, grooving or fracture at any time during the test.

3.7.11 Repeated Load Test with One Anchor Bolt

3.7.11.1 After completion of the Vertical and Lateral Repeated Load Test, the fastener shall be reassembled as specified using only the original components previously subjected to testing. The Vertical and Lateral Repeated Load Test shall then be repeated with a minimum of 15,000 cycles with the gauge side anchor bolt loosened to a minimum of 1/4" gap.

3.7.11.2 Acceptance Criteria

3.7.11.3 The fastener and concrete block shall withstand the 15,000 cycles of loading with the gauge side anchor bolt loosened with no evidence of failure by slippage, yielding or fracture.

3.7.12 Heat-Aging Process

3.7.12.1 A fastener shall be fully assembled as specified above except the anchor bolts need not be installed and the fastener shall be aged in an air oven for a period of 166 hours at a temperature of 70° C using the aging methods specified in ASTM Designation D573, "Accelerated Aging of Vulcanized Rubber by the Oven Method". This is a conditioning process for the fasteners that will be further tested as indicated in Section 3.10.3.

3.7.13 Corrosion Process

3.7.13.1 The fastener body shall be exposed, without loose components, to a 5 % solution in accordance with ASTM B117, "Standard Test Method for Salt Spray (Fog) Testing", for 744 hours. This is a conditioning process for the fasteners that will be further tested as indicated in Section 3.10.3..

3.7.14 Uplift Repeated Load Test

3.7.14.1 The Rail Fasteners, fully assembled as specified above, shall have loads applied to the rail head in such a manner as to produce alternating vertical downward load of 20,800 lbs. and a vertical upward load of 4,800 lbs. at the centerline of the rail and midway between the two fasteners normal to the rail. The application of the two vertical loads shall constitute one complete cycle and shall be applied for a minimum of 1.5 million cycles. The frequency shall be regulated to prevent the components' temperature from exceeding 70 C. Retorquing threaded elements subsequent to completion of 500,000 cycles of loading will not be permitted.

3.7.14.2 Acceptance Criteria

3.7.14.3 The fastener shall withstand 1.5 million complete cycles of load application with no evidence of failure. Upon visual inspection, no component of the fastener, shall exhibit any evidence of failure by yielding, slippage or fracture. The rail shall exhibit no evidence of wear or grooving that would contribute to a failure of the rail under operating conditions.

3.7.15 Push-Pull Test

3.7.15.1 During the Push-Pull Test, the rail ends shall be supported on rollers or other low friction supports, properly elevated to prevent the longitudinal load from binding the rail in the fasteners.

3.7.15.2 A cycling longitudinal load shall be applied to the centroid of the rail at one end to deflect the rail plus and minus 3/4" about the initial position for a total of 50 cycles. Immediately afterward, a cycling load equal to 80% of the ultimate slippage loads as recorded in the longitudinal restraint test shall be applied for a total of 25,000 pushing and pulling cycles. Repositioning of the rail clips at anytime will not be permitted.

3.7.15.3 Acceptance Criteria

3.7.15.4 The fastener shall withstand 25,000 cycles of loading with no evidence of failure. Upon visual examination, no component of the fastener, shall exhibit

any evidence of failure by yielding slippage or fracture, except that slippage may occur between rail clips and rail but not between rail clips and the fastener body. The rail shall exhibit no evidence of wear or grooving that would contribute to rail failure under operating conditions.

3.7.16 Dynamic to Static Stiffness Ratio Test

3.7.16.1 Using the same assemblage as noted in the Vertical Load Test, an oscillating downward load shall be applied at the centerline of the rail head and the centerline of the fastener so as to produce a sinusoidal load alternating between 8,000 and 18,000 lbs. at a rate of between 10 and 20 hertz. The load and deflection versus time shall be continuously recorded on a high speed oscillograph or high speed digital recorder. After a minimum of 1,000 cycles, the dynamic stiffness shall be determined from the ratio of peak-to-trough force to peak-to-trough deflection from the recorded data.

3.7.16.2 Between five to ten minutes after completion of the dynamic stiffness measurement and removal of all load, a vertical load shall be applied beginning at 0 lbs. and increasing in 2,000 lb.increments to a maximum of 20,000 lbs., at a rate not less than 200 lbs. per minute nor more than 2,000 lbs. per minute, at the centerline of the fastener assembly. For each increment of load between 2,000 and 20,000 lbs., the vertical deflection of the rail head shall be recorded to the nearest 0.001". The static stiffness of the fastener shall be the difference in load divided by the difference in deflection between 8,000 and 18,000 lbs..

3.7.16.3 Acceptance Criteria: The dynamic stiffness shall not exceed 1.4 times the static stiffness.

3.8 PRODUCTION QUALITY CONTROL

3.8.1 Following successful completion of the qualification tests, acceptance of the qualification test reports by WMATA, and start of the fastener assembly manufacturing, production type quality control sampling and testing shall be conducted.

3.8.2 The qualification tests specified in this Specification document shall be performed by an independent testing facility approved by WMATA and shall be a member of the American Council of Independent Laboratories.

3.8.3 Elastomer samples and fastener assemblies shall be selected from regular production and subjected to testing to ensure that high quality standards are maintained and that design requirements set forth in these specifications are met through the completion of the production process.

3.8.4 Production Elastomer Tests

3.8.4.1 Samples of elastomer from every mixed batch of material used in the manufacture of production fastener shall be tested to verify compliance of the elastomer batch mix with the following testing requirements:

- a) Hardness Test**
- b) Tensile Strength and Ultimate Elongation Test**
- c) Specific gravity: and**
- d) Cure Characteristic in accordance with ASTM D2084 or an equivalent industry accepted standard.**

3.8.4.2 Certificate of Compliance from the supplier of the elastomer shall be submitted to WMATA guaranteeing compliance of the elastomer with requirements of these specifications.

3.8.5 Fastener Assembly Tests

3.8.5.1 Two (2) Rail Fasteners shall be selected from the initial 50 Rail Fasteners and from each production lot or portion thereof, produced thereafter. The fasteners used for production testing and meeting all test requirements as production test fasteners shall permanently be marked and delivered to the Authority. These fasteners shall be subjected to the following tests:

- a) Vertical Load Test**
- b) Vertical Uplift Test**
- c) Lateral Load Test**
- d) Lateral Restraint Test**
- e) Longitudinal Restraint Test**
- f) Voltage Withstand Test**
- g) Electrical Resistance Test**
- h) Vertical and Lateral Repeated Load Test (500,000 cycles)**

- 3.8.5.2 The configuration for testing and the acceptance criteria shall be as specified above, and the value obtained for the slope of the load-deflection curve in the Vertical load Test shall be within 20 % of that obtained in the original compliance testing.
- 3.8.5.3 The quality control tests shall commence no later than fourteen (14) days after fabrication of the fastener. Should any fastener fail to meet the test requirements, two (2) additional fasteners from that same production lot shall be tested. In the event any of the two (2) additional fasteners fail, 100 % of the remainder of the lot shall be rejected or tested and only those successfully passing all tests shall be incorporated in the final delivered quantity.
- 3.8.5.4 In addition to the quality control tests and at the discretion of the Engineer, all components of the Rail Fasteners shall be subjected to full or partial testing for compliance with these specifications. The cost of all such additional testing required by WMATA for any component that is proved to comply with these specifications will be at the expense of the Authority. The cost of all such additional testing of any component that is proven not to comply with these specifications shall be at no expense to the Authority.
- 3.8.5.5 Production quality control testing may be performed at any test facility, including such facilities at the Contractor's plant, provided they meet the approval of WMATA and satisfies the requirements of the American Council of Independent Laboratories "Manual of Practice, Quality Control System" - Requirements for Testing and Inspection Laboratory, and ASTM E320. Testing equipment shall be in good repair, of adequate capacity and shall be accurately calibrated. Copies of calibration certificates shall be submitted to WMATA. WMATA shall be notified not less than 14 days in advance of dates scheduled for quality control tests.
- 3.8.5.6 Two (2) copies of the results of all tests shall be submitted to WMATA within seven (7) days after performance of the tests.

3.8.6 Acceptance

- 3.8.6.1 Final acceptance of production lots of direct fixation rail fasteners will be based upon the fastener and all its components complying with these specifications as determined by WMATA, based on the results of the quality control tests and the certified statements submitted to WMATA by the Contractor.

3.9 DELIVERY CONDITIONS

3.9.1 Rail fastener bodies shall be packed in waterproof and weatherproof containers, banded on pallets for forklift handling. Rail clips and rail anchor assemblies shall be packed in separate water proof and weatherproof containers, banded on pallets for forklift handling. Clearly mark each container with identification of the item contained, supplier's name, shipping date, number of pieces, destination, and gross weight.

3.10 REFERENCE DRAWINGS

3.10.1 Fastener Clearance Envelope

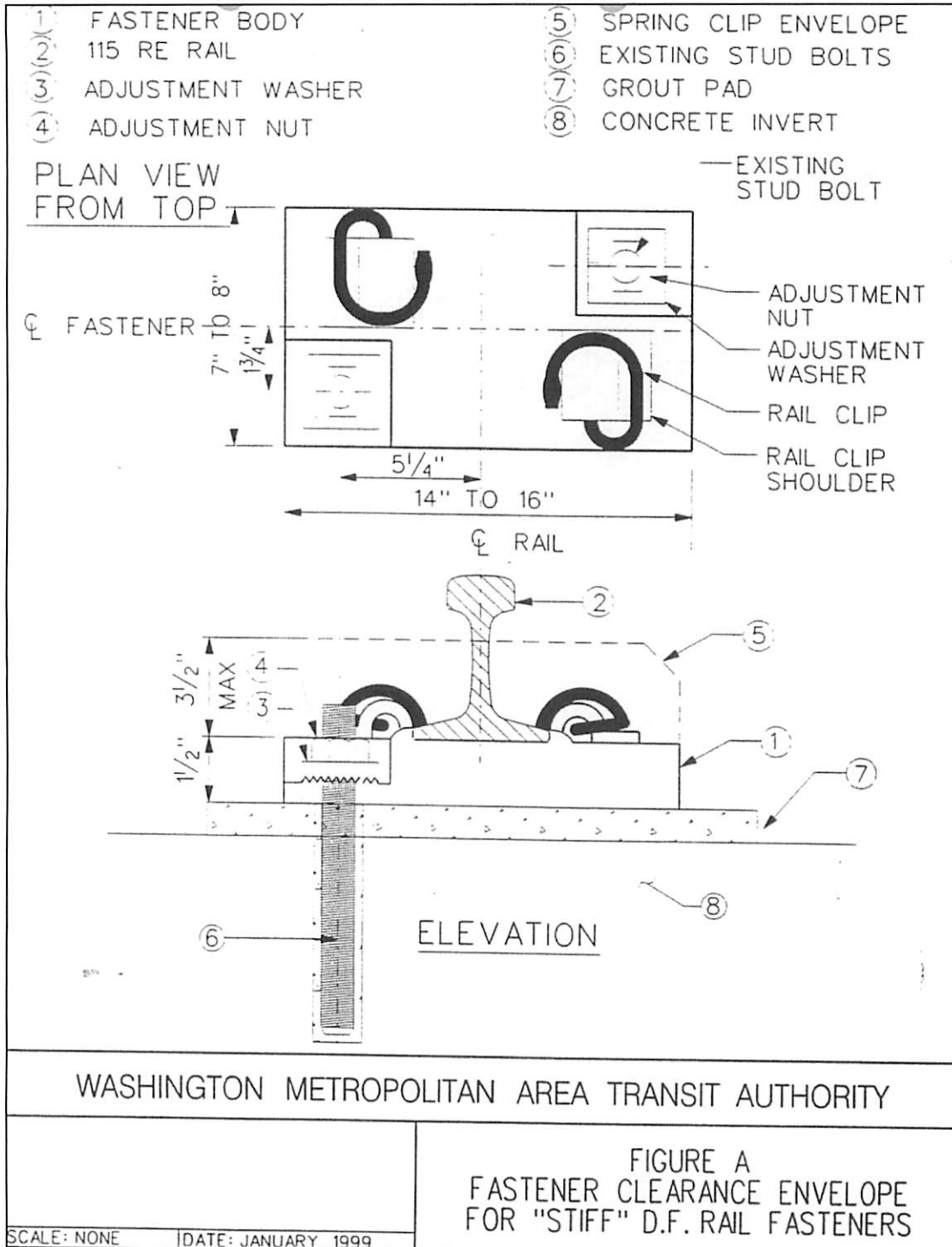

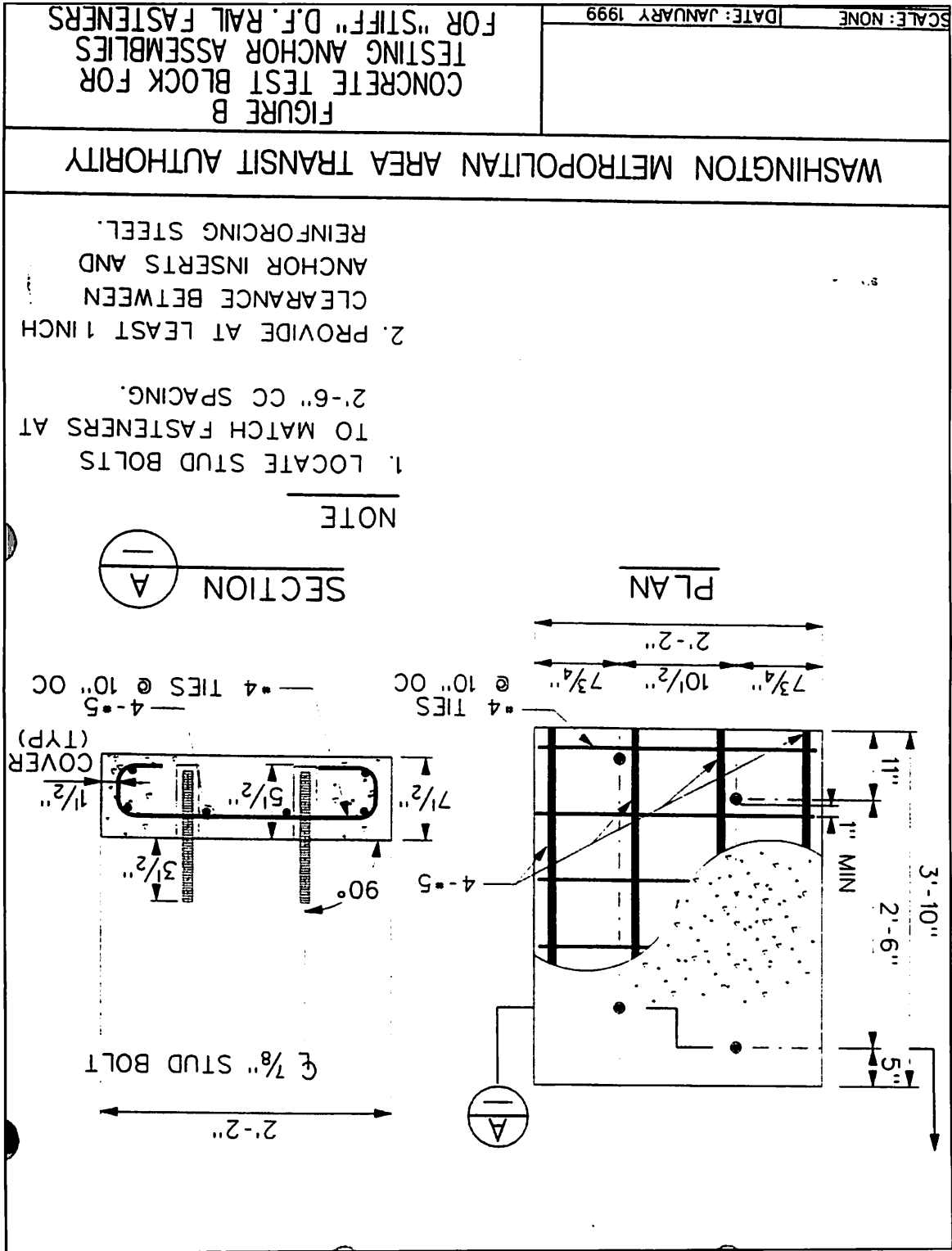

3.10.2 Concrete Test Block for Testing Anchor Assemblies

3.10.3 Fastener Assemblies Qualification Testing Sequence

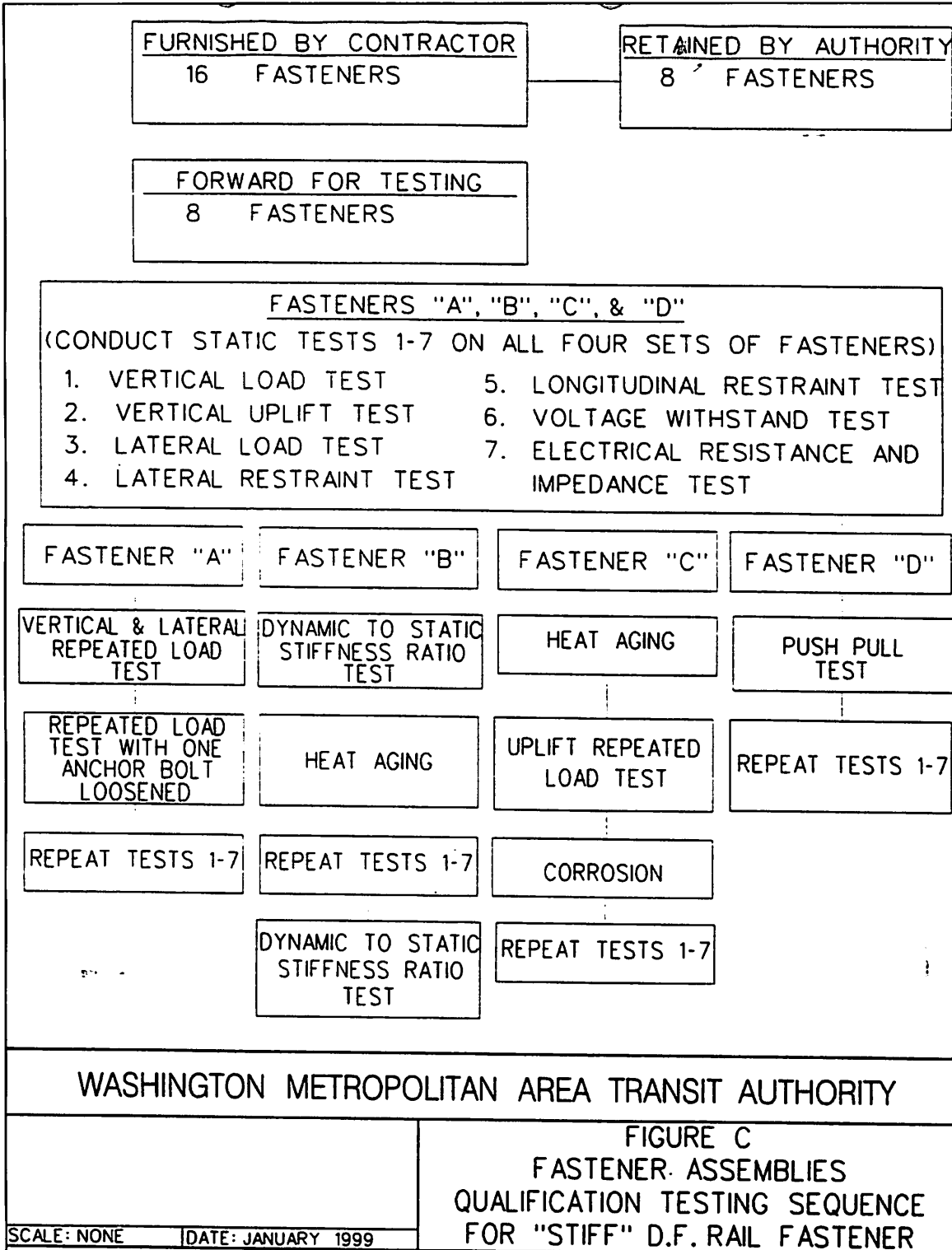

3.10.4 Vertical Load Test Acceptance Criteria

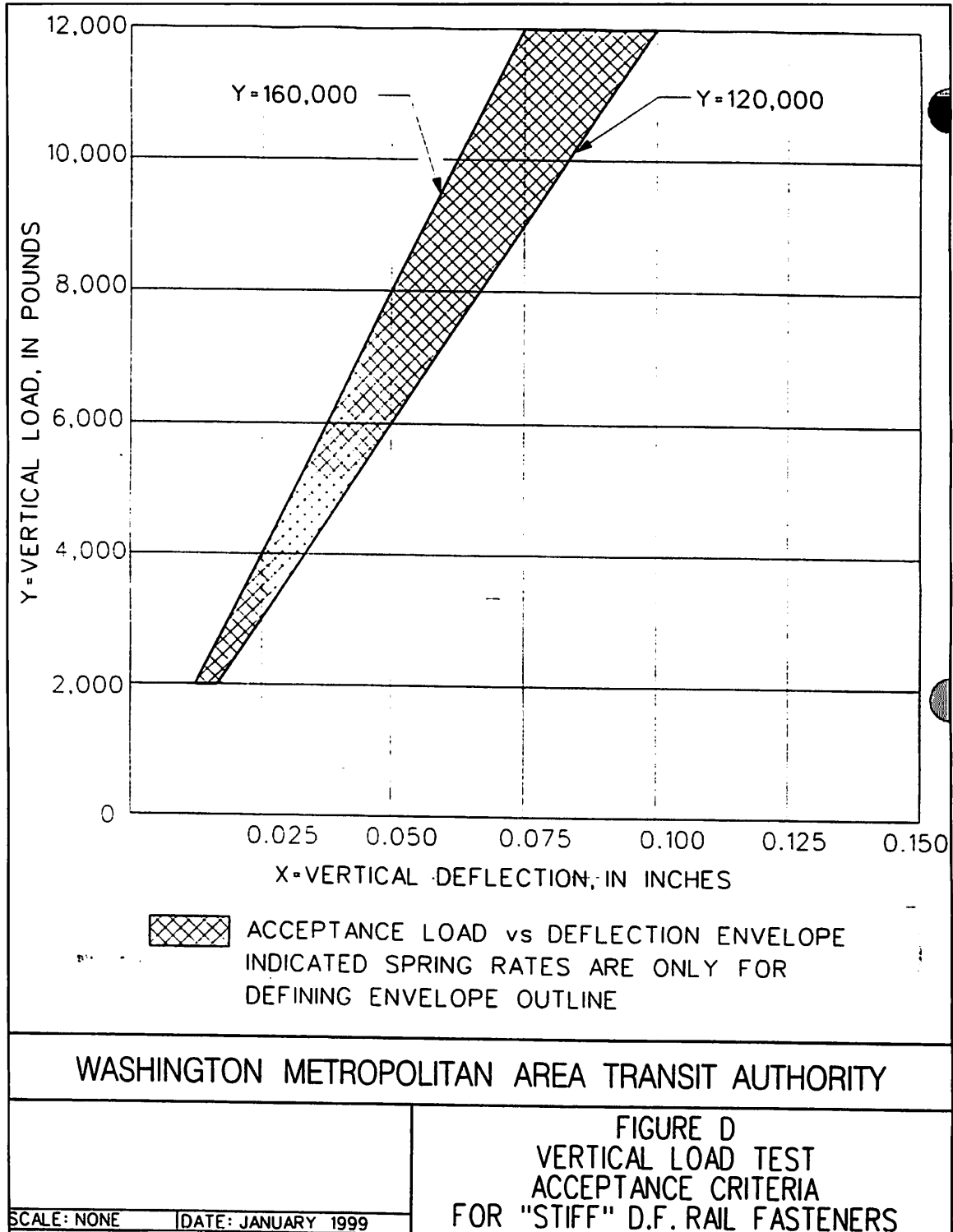

3.10.5 Lateral Load Test Acceptance Criteria

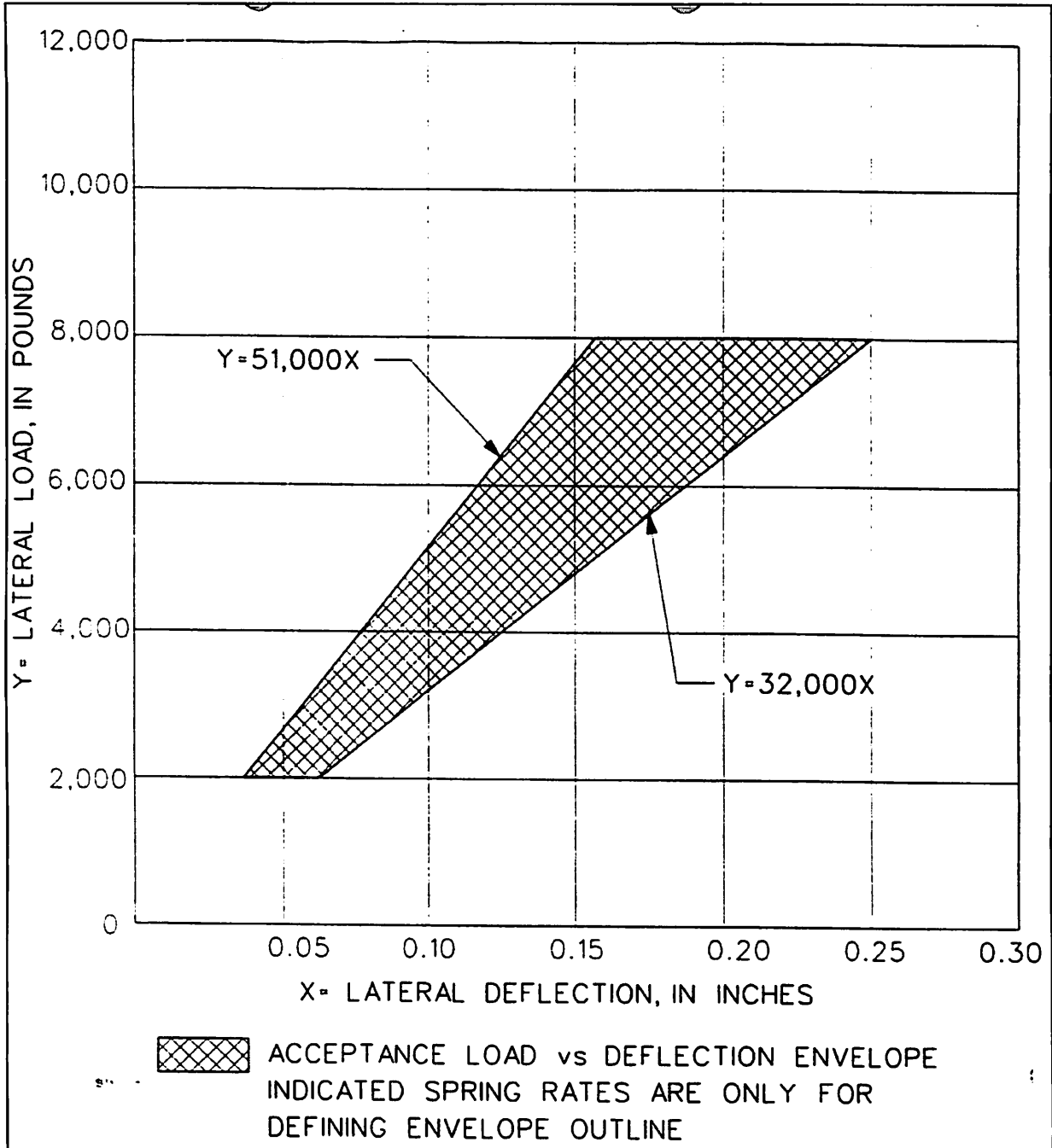

WASHINGTON METROPOLITAN AREA TRANSIT AUTHORITY

FIGURE E
 LATERAL LOAD TEST
 ACCEPTANCE CRITERIA
 FOR "STIFF" D.F. RAIL FASTENERS

SCALE: NONE | DATE: JANUARY 1999

3.10.6 Longitudinal Restraint

